

# TRY\_28 TV

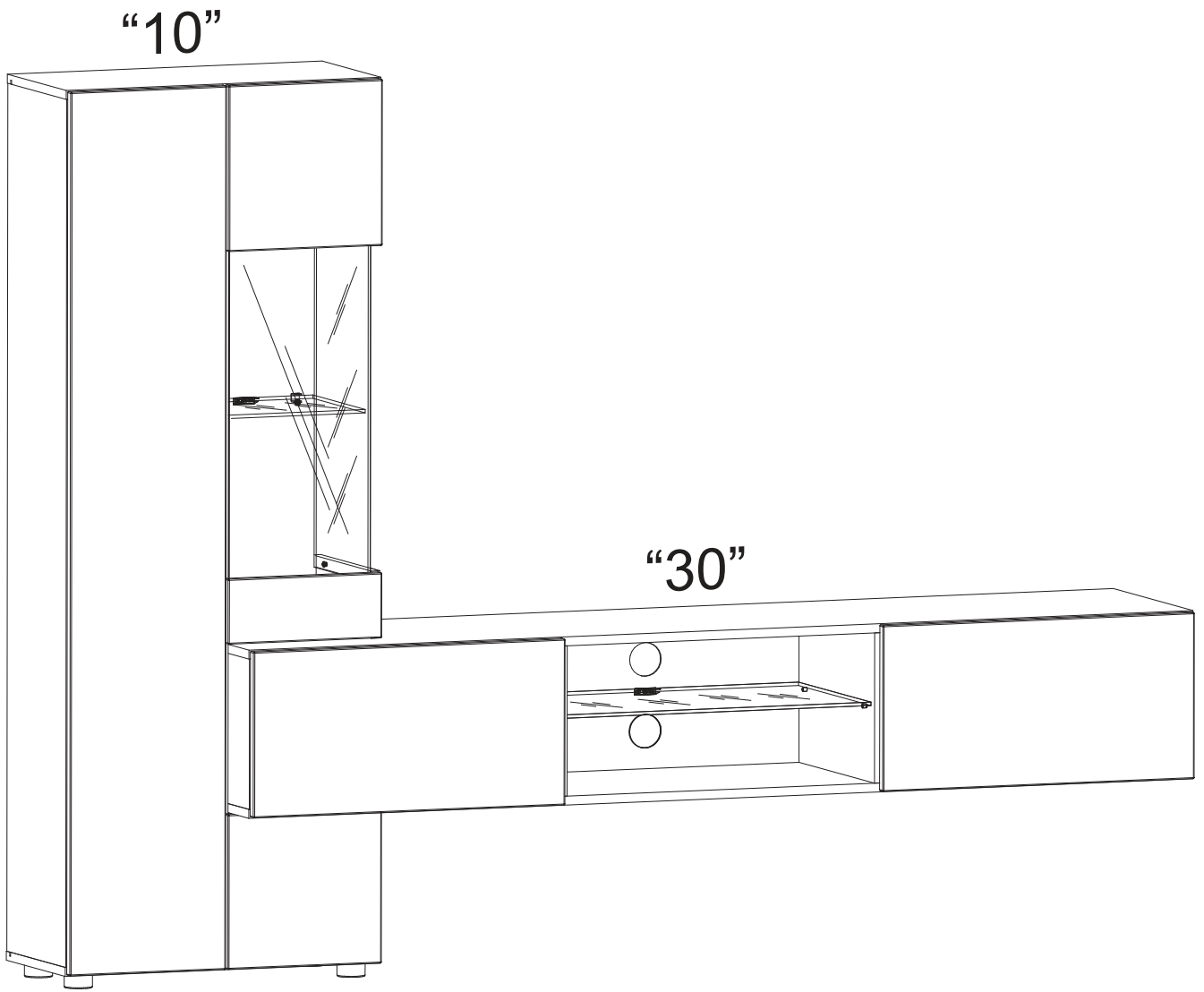

# TRY\_28 TV

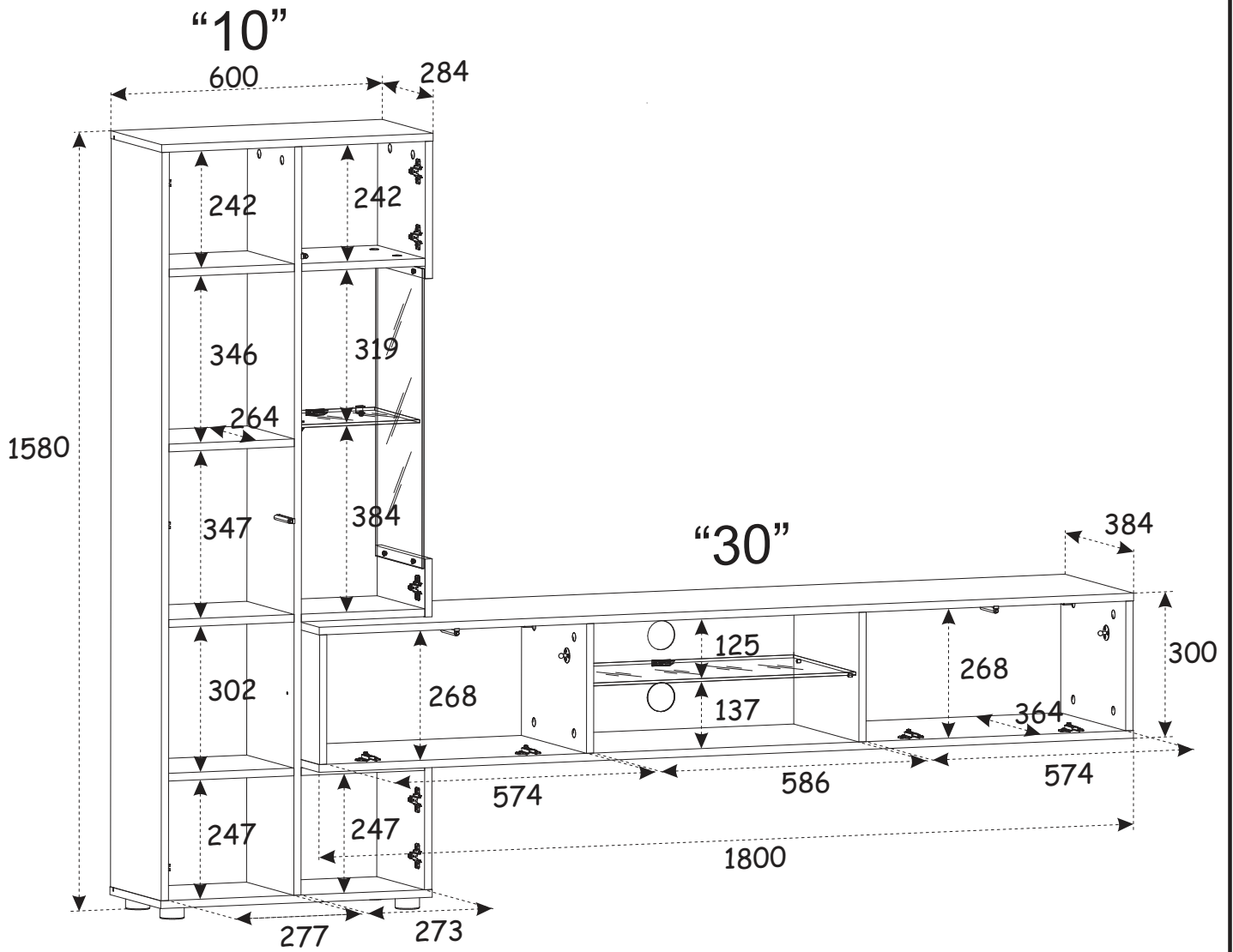

# TRY\_28 - TYP 10

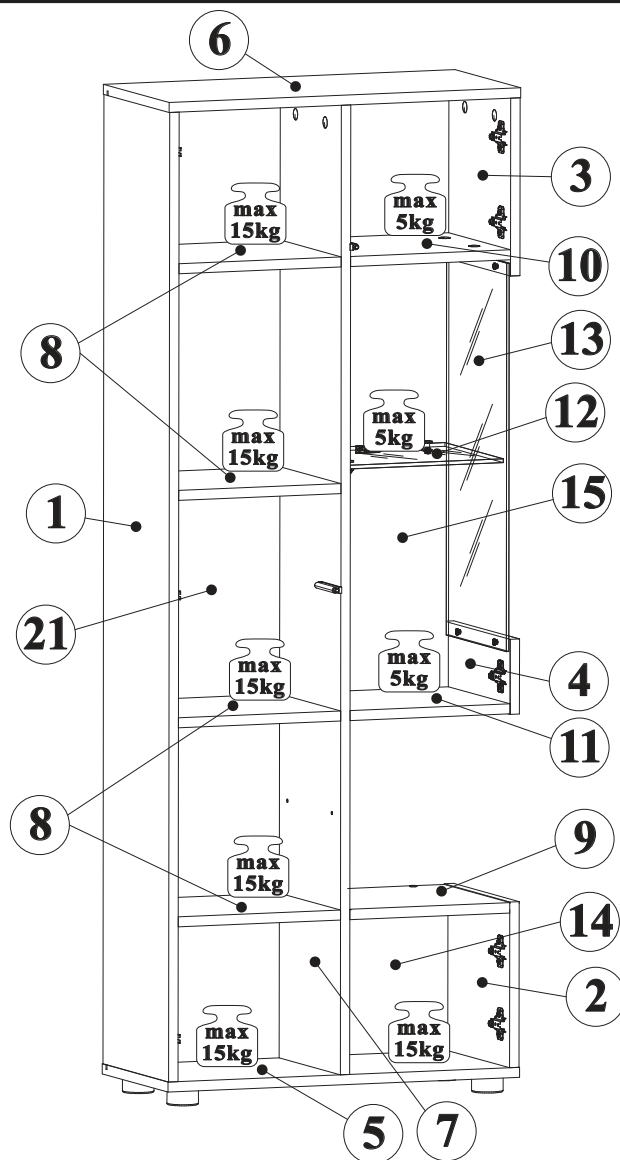
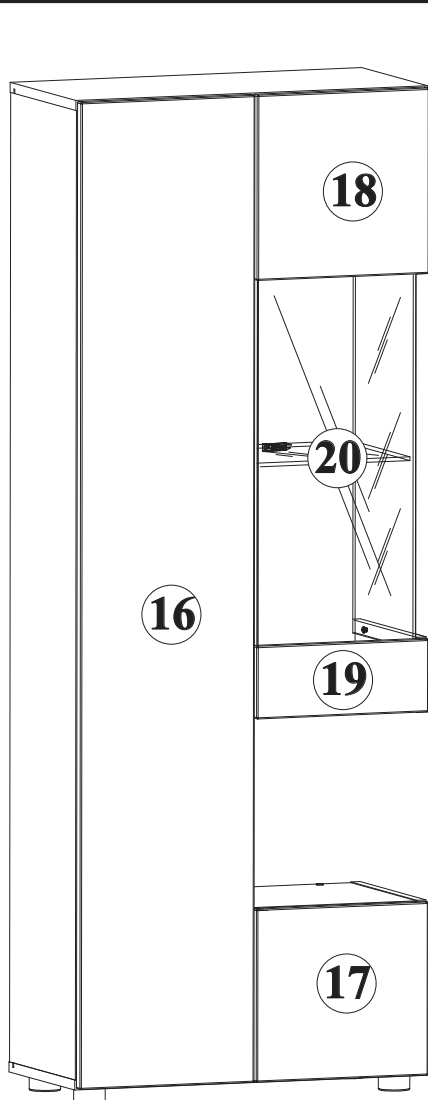

| NO | Dim  |     |    | Col.-No | Qty |
|----|------|-----|----|---------|-----|
| 1  | 1548 | 284 | 16 | 2       | 1   |
| 2  | 264  | 284 | 16 | 1       | 1   |
| 3  | 284  | 284 | 16 | 1       | 1   |
| 4  | 284  | 120 | 16 | 1       | 1   |
| 5  | 600  | 284 | 16 | 1       | 1   |
| 6  | 600  | 284 | 16 | 1       | 1   |
| 7  | 1548 | 284 | 16 | 2       | 1   |
| 8  | 277  | 264 | 16 | 1       | 4   |
| 9  | 273  | 284 | 16 | 1       | 1   |
| 10 | 273  | 267 | 16 | 1       | 1   |
| 11 | 273  | 267 | 16 | 1       | 1   |
| 12 | 263  | 252 | 6  | 1       | 1   |
| 13 | 620  | 260 | 4  | 1       | 1   |
| 14 | 247  | 273 | 16 | 2       | 1   |
| 15 | 984  | 273 | 16 | 2       | 1   |

| NO | Dim  |      |    | Col.-No | Qty |
|----|------|------|----|---------|-----|
| 16 | 297  | 1576 | 16 | 2       | 1   |
| 17 | 293  | 276  | 16 | 2       | 1   |
| 18 | 293  | 296  | 16 | 2       | 1   |
| 19 | 293  | 116  | 16 | 2       | 1   |
| 20 | 624  | 269  | 4  | 1       | 1   |
| 21 | 1560 | 289  | 3  | 2       | 1   |

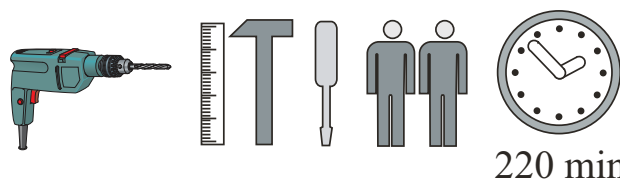

220 min

# TRY\_28 - TYP 30

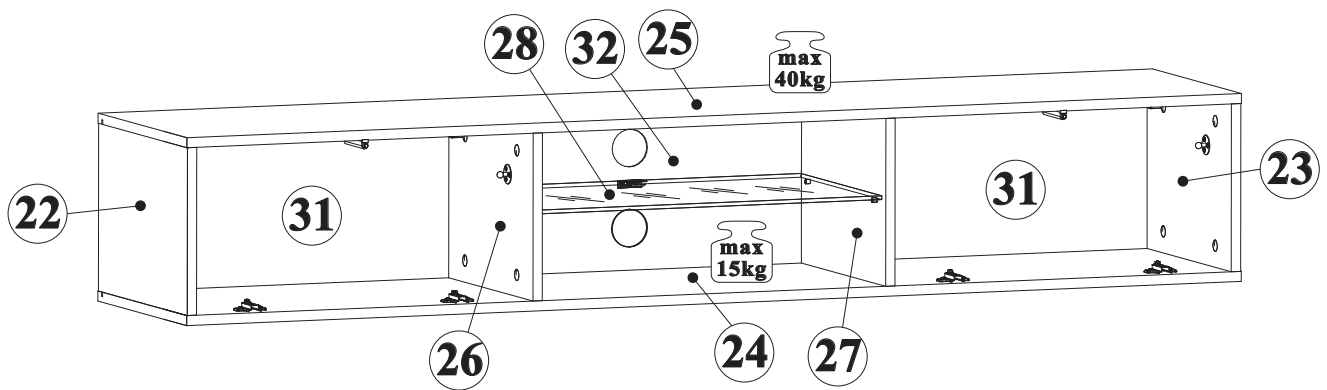
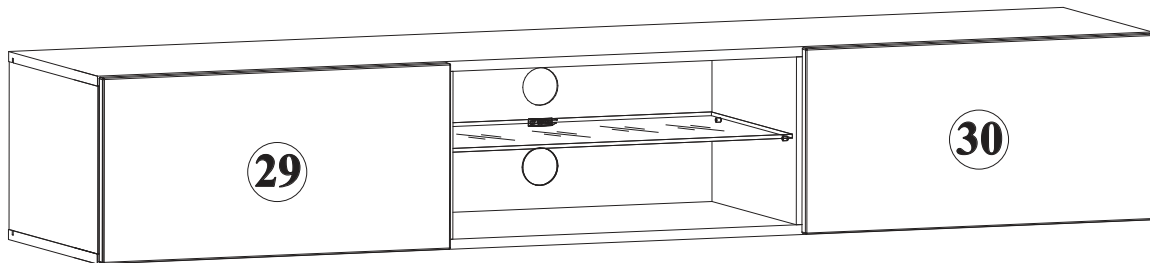



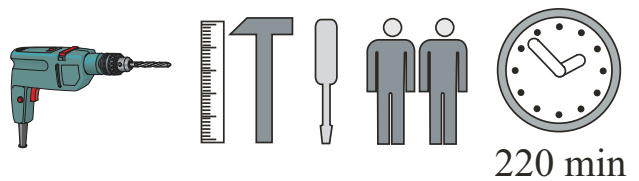



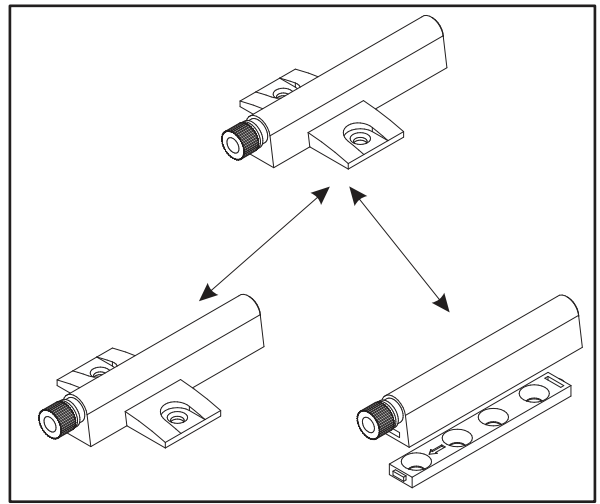
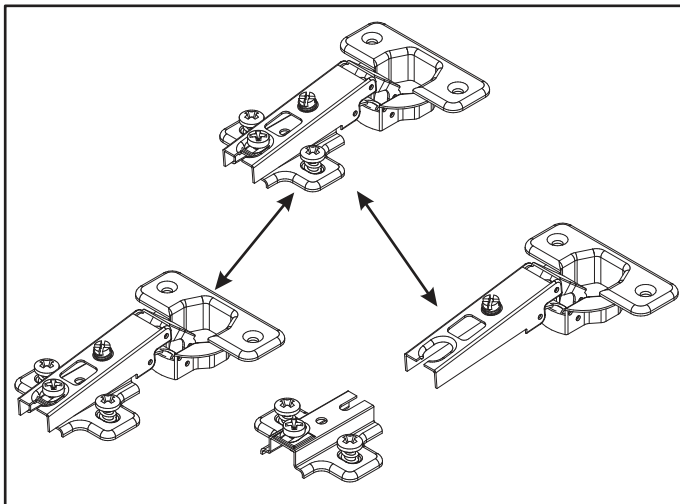
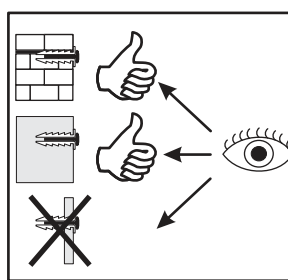
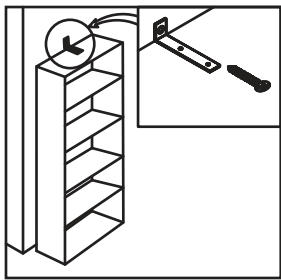
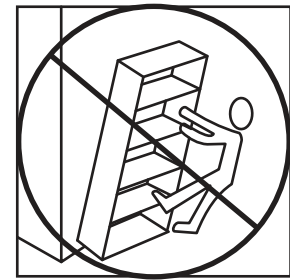
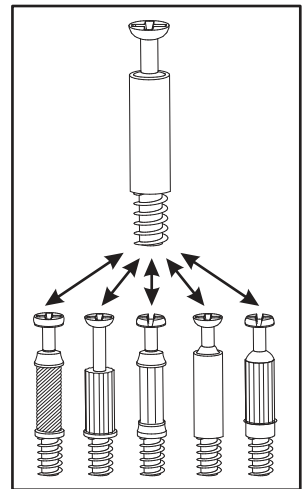
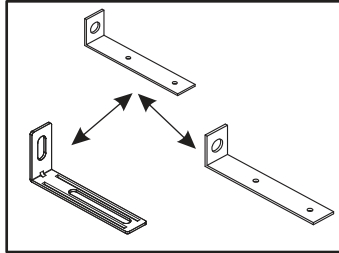
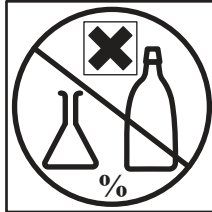
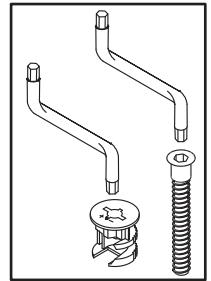
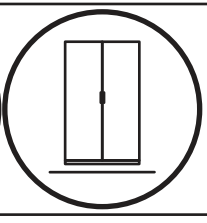
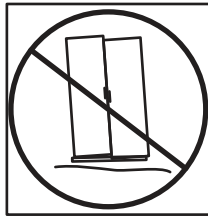
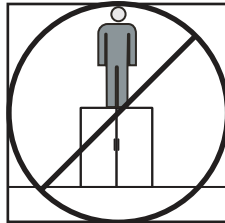
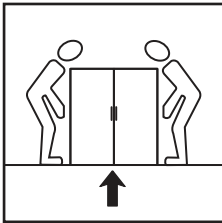
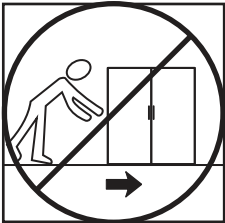
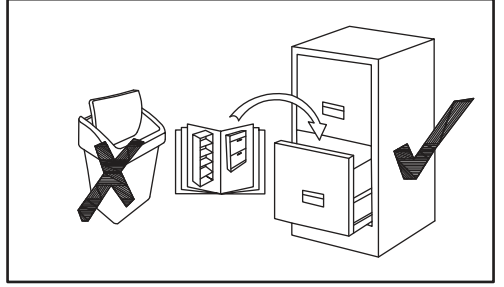
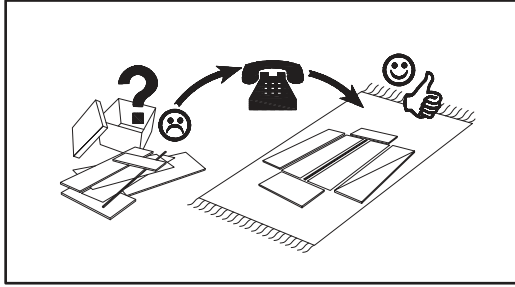
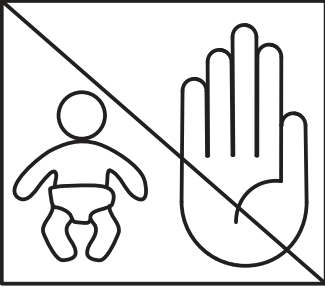
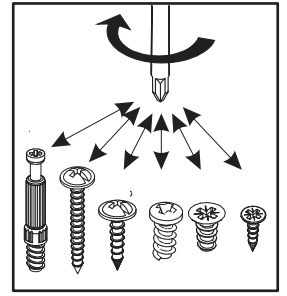
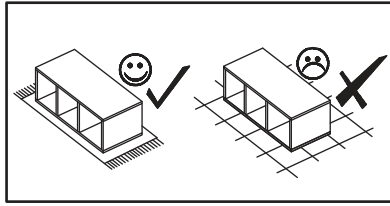
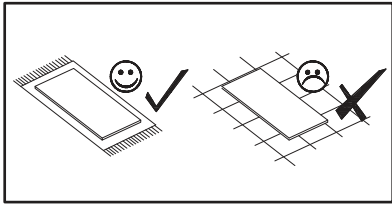



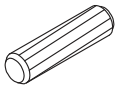

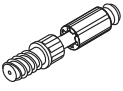



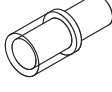
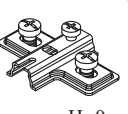
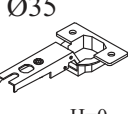

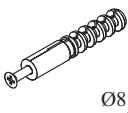
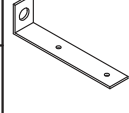
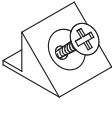
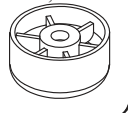
| NO | Dim  |     |    | Col.-No | Qty |
|----|------|-----|----|---------|-----|
| 22 | 268  | 384 | 16 | 3       | 1   |
| 23 | 268  | 384 | 16 | 3       | 1   |
| 24 | 1800 | 384 | 16 | 3       | 1   |
| 25 | 1800 | 384 | 16 | 3       | 1   |
| 26 | 268  | 364 | 16 | 3       | 1   |
| 27 | 268  | 364 | 16 | 3       | 1   |
| 28 | 584  | 349 | 6  | 3       | 1   |
| 29 | 594  | 296 | 16 | 3       | 1   |
| 30 | 594  | 296 | 16 | 3       | 1   |
| 31 | 587  | 280 | 3  | 3       | 1   |
| 31 | 587  | 280 | 3  | 3       | 1   |
| 32 | 600  | 280 | 3  | 3       | 1   |

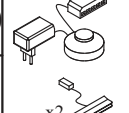

220 min

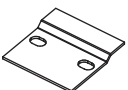

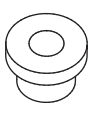
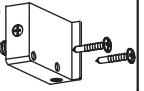
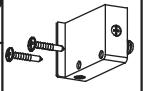
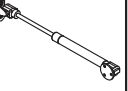
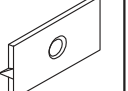
# TRY\_28 TV

|   |  |  |  |   |  |
|---|--|--|--|---|--|
| A1<br>x56<br><br>Ø8x36     | B11<br>x14<br><br>Ø7x50 | G4<br>x14<br> | B4<br>x42<br>              | B6<br>x6<br><br>Ø7x76        | B5<br>x54<br><br>Ø15x12     |
| G5<br>x56<br>              | G8<br>x2<br><br>Ø20     | G20<br>x4<br> | E2<br>x12<br><br>H=0       | E21<br>x12<br><br>Ø35<br>H=0 | D6<br>x10<br><br>USØ3,5x30  |
| KR1<br>x9<br><br>Ø8        | L1<br>x1<br>            | S1<br>x26<br> | ST7<br>x4<br><br>Ø50, h=25 | UP11<br>x4<br><br>UPØ4x20    | D10<br>x56<br><br>USØ3,5x13 |
| UP13<br>x20<br><br>UPØ3x16 | LED<br>x1<br><br>x2     | T1<br>x5<br>  | SZ7<br>x4<br>              | G30<br>x4<br>                | P2<br>x8<br>                |
| ZXL<br>x2<br>              | ZXP<br>x2<br>           | BO1<br>x4<br> | G16<br>x4<br>              | G2<br>x1<br>                 |  |

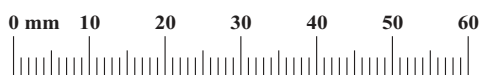
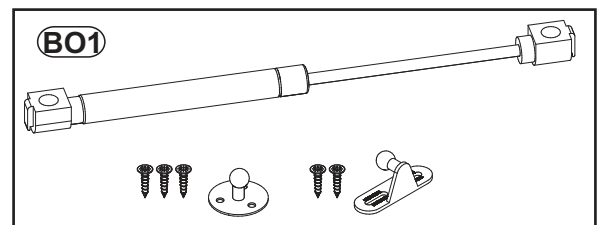
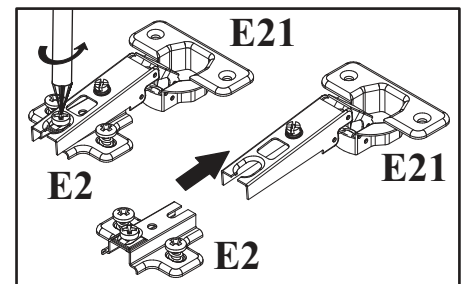

1

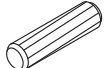
|    |  |
|----|--|
| A1 |  |
| x4 | ∅8x36  |

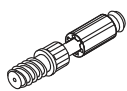

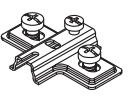

|    |   |
|----|---|
| B4 |  |
| x8 |   |

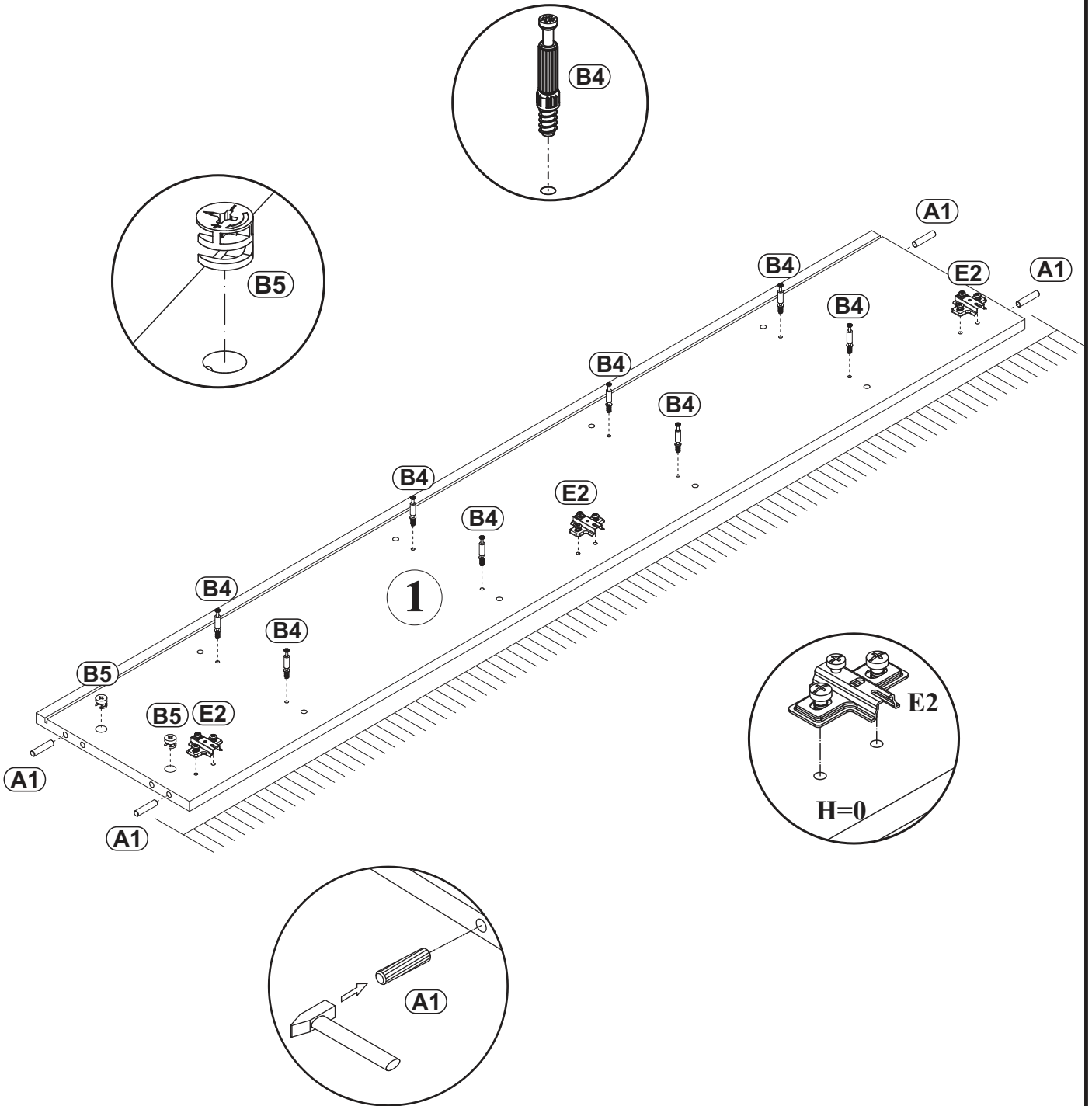
|    |   |
|----|---|
| B5 |  |
| x2 | ∅15x12  |

|    |   |
|----|---|
| E2 |  |
| x3 | H=0   |

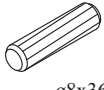
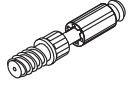
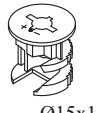

2

|     |  |     |   |    |   |
|-----|--|-----|---|----|---|
| A1  |  | B4  |  | B5 |  |
| x4  | ø8x36  | x2  |   | x2 | Ø15x12  |
| G30 |  | D10 |  | T1 |  |
| x2  |  | x6  | USØ3,5x13   | x3 |   |

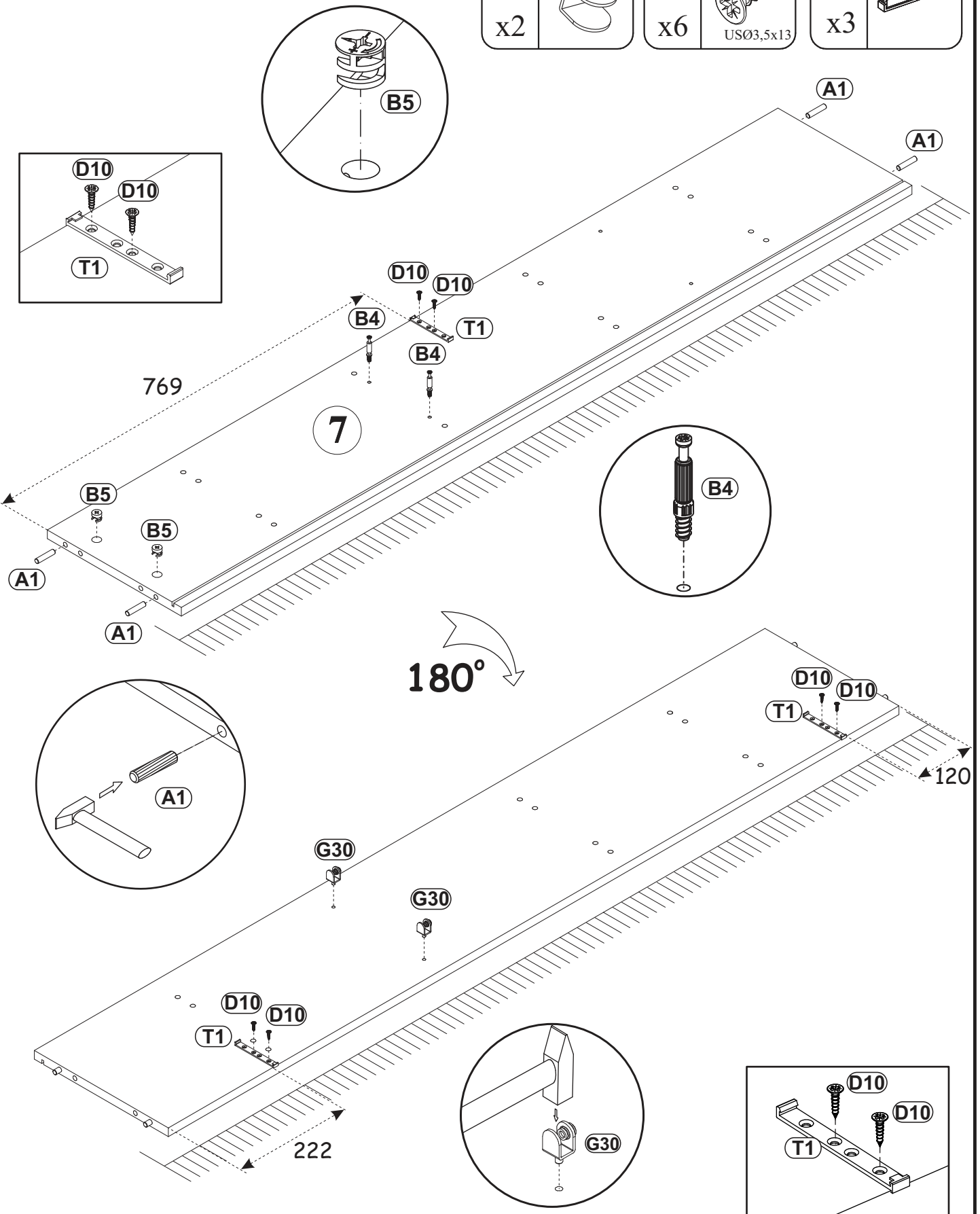

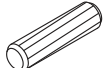

3

|    |  |
|----|--|
| A1 |  |
| x4 | ∅8x36  |

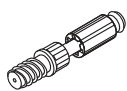
|    |   |
|----|---|
| B4 |  |
| x8 |   |

|    |   |
|----|---|
| B5 |  |
| x2 | ∅15x12  |

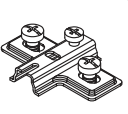
|    |   |
|----|---|
| E2 |  |
| x5 | H=0   |

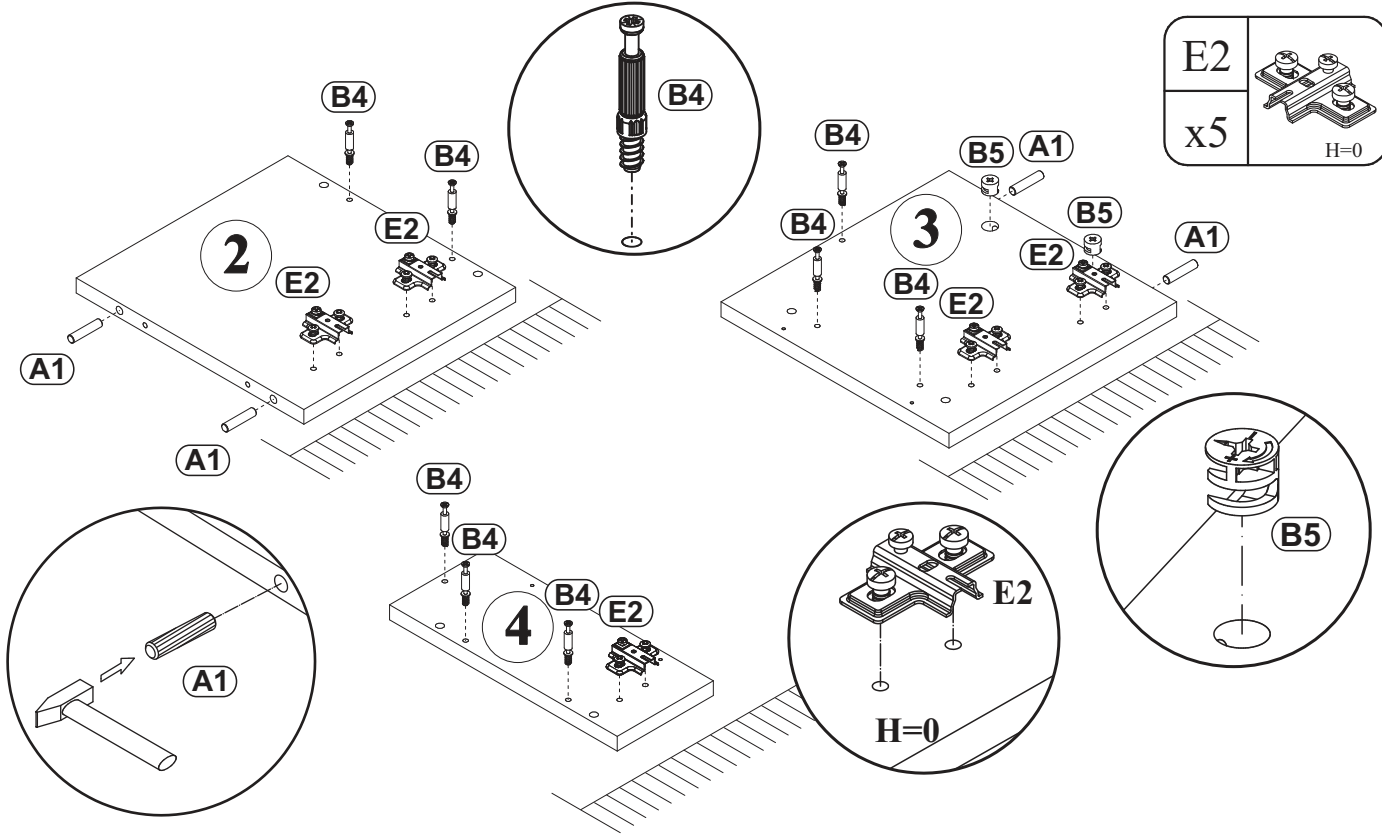

4

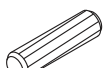
|     |  |
|-----|--|
| A1  |  |
| x24 | ∅8x36  |

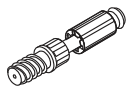
|    |   |
|----|---|
| B4 |  |
| x8 |   |

|     |   |
|-----|---|
| B5  |  |
| x24 | ∅15x12  |

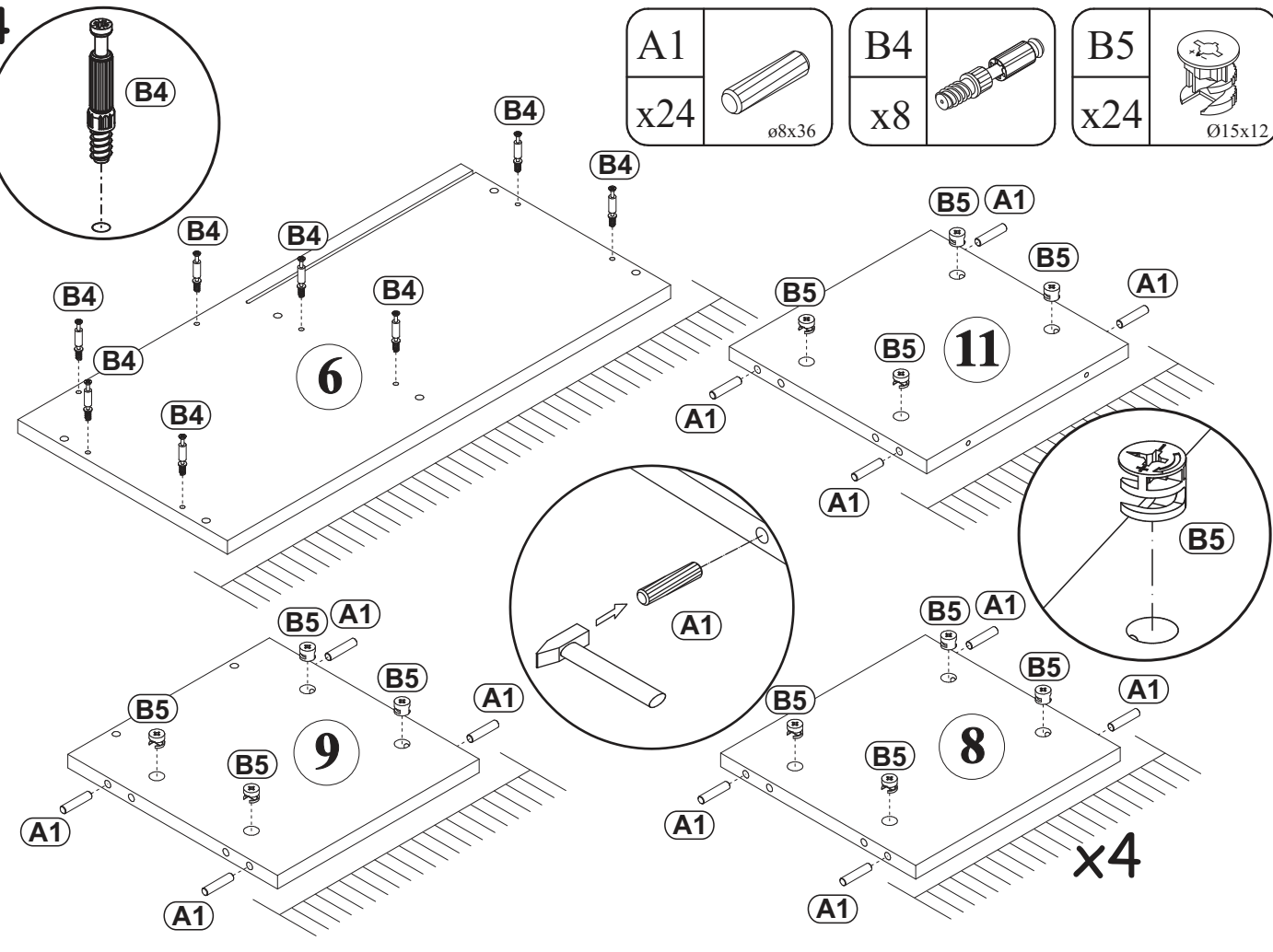

5

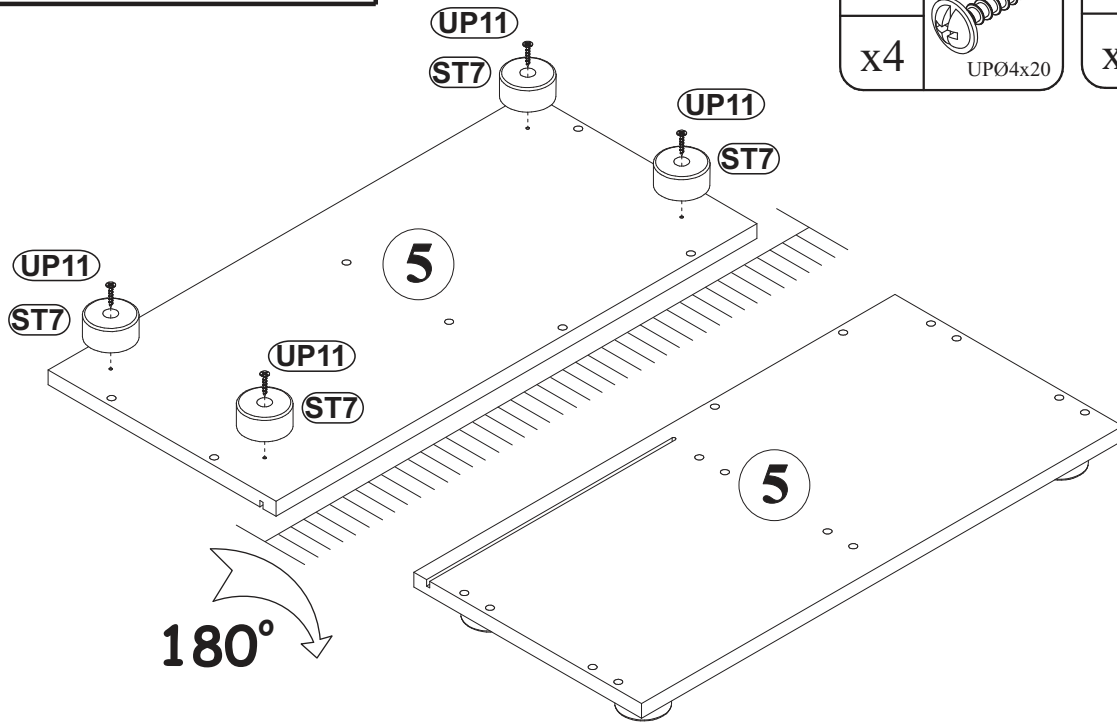

|      |         |
|------|---------|
| UP11 |         |
| x4   | UPØ4x20 |

|     |           |
|-----|-----------|
| ST7 |           |
| x4  | Ø50, h=25 |

6

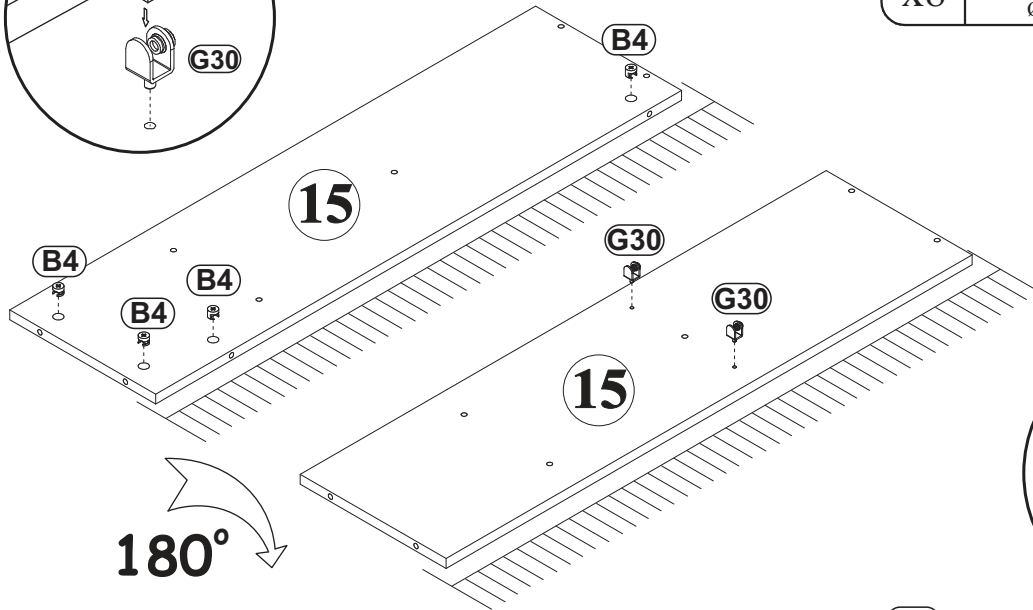
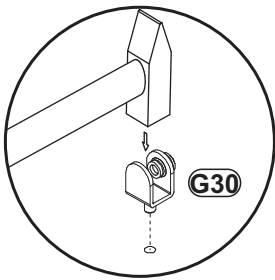

|    |        |
|----|--------|
| B5 |        |
| x8 | Ø15x12 |

|    |       |
|----|-------|
| A1 |       |
| x4 | Ø8x36 |

|     |  |
|-----|--|
| G30 |  |
| x2  |  |

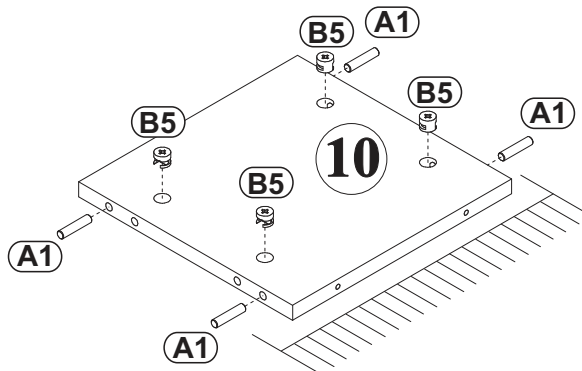
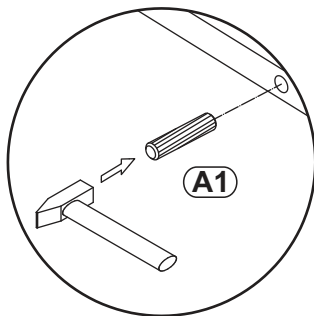
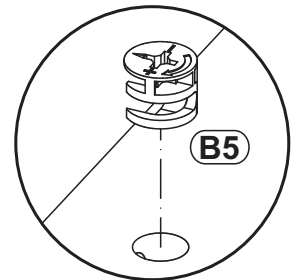



9

|     |       |
|-----|-------|
| A1  |       |
| x16 | Ø8x36 |

|     |  |
|-----|--|
| ZXP |  |
| x2  |  |

|     |  |
|-----|--|
| ZXL |  |
| x2  |  |

|     |        |
|-----|--------|
| B5  |        |
| x16 | Ø15x12 |

|     |  |
|-----|--|
| BO1 |  |
| x4  |  |

|     |           |
|-----|-----------|
| D10 |           |
| x12 | USØ3,5x13 |

|     |  |
|-----|--|
| G20 |  |
| x4  |  |

|    |           |
|----|-----------|
| D6 |           |
| x8 | USØ3,5x30 |

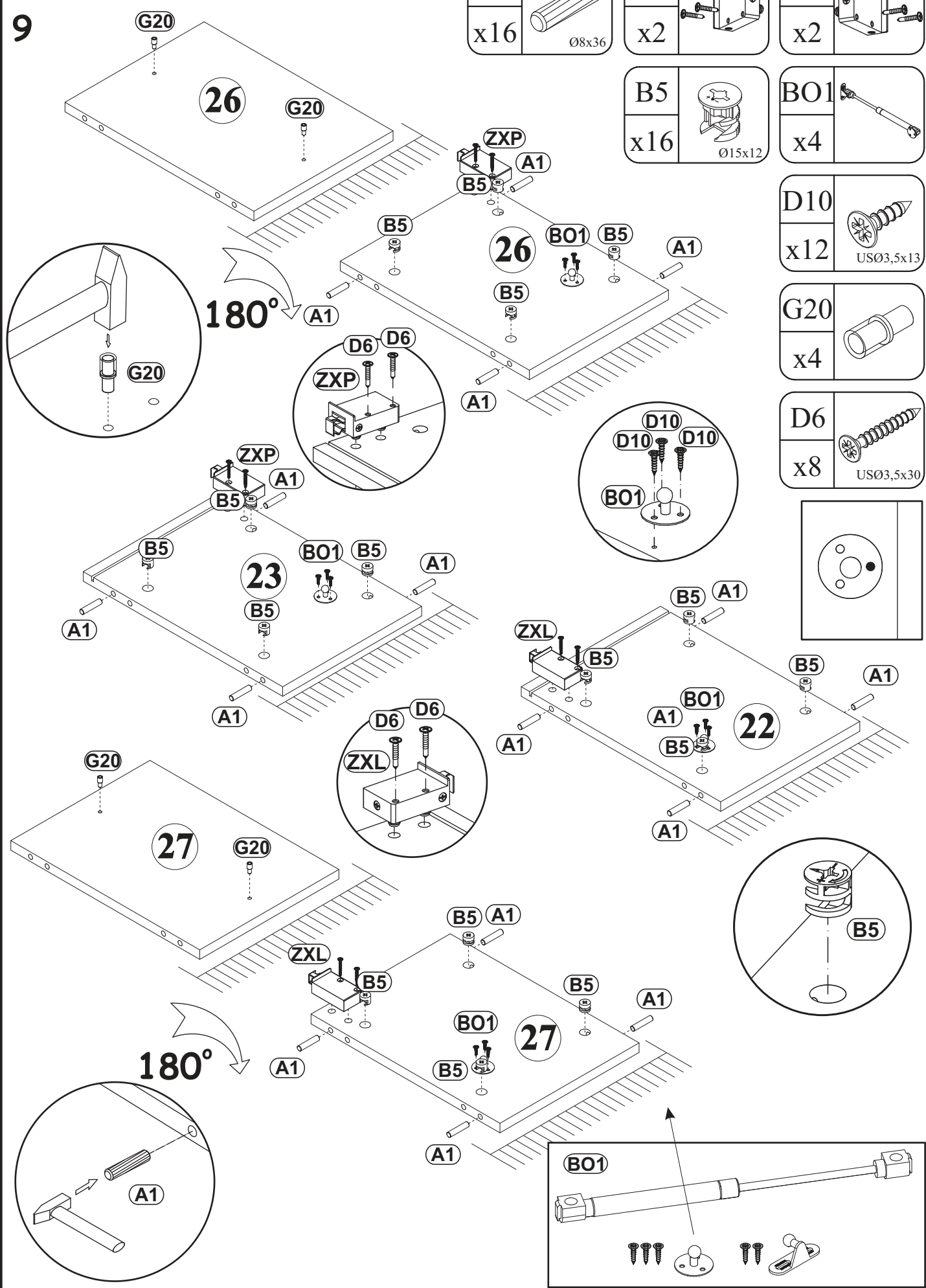
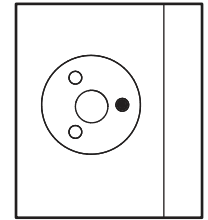

|     |  |
|-----|--|
| BO1 |  |
|-----|--|

10

|     |   |
|-----|---|
| D10 |  |
| x10 | USØ3,5x13   |

|     |     |
|-----|-----|
| E21 | Ø35 |
| x5  | H=0 |

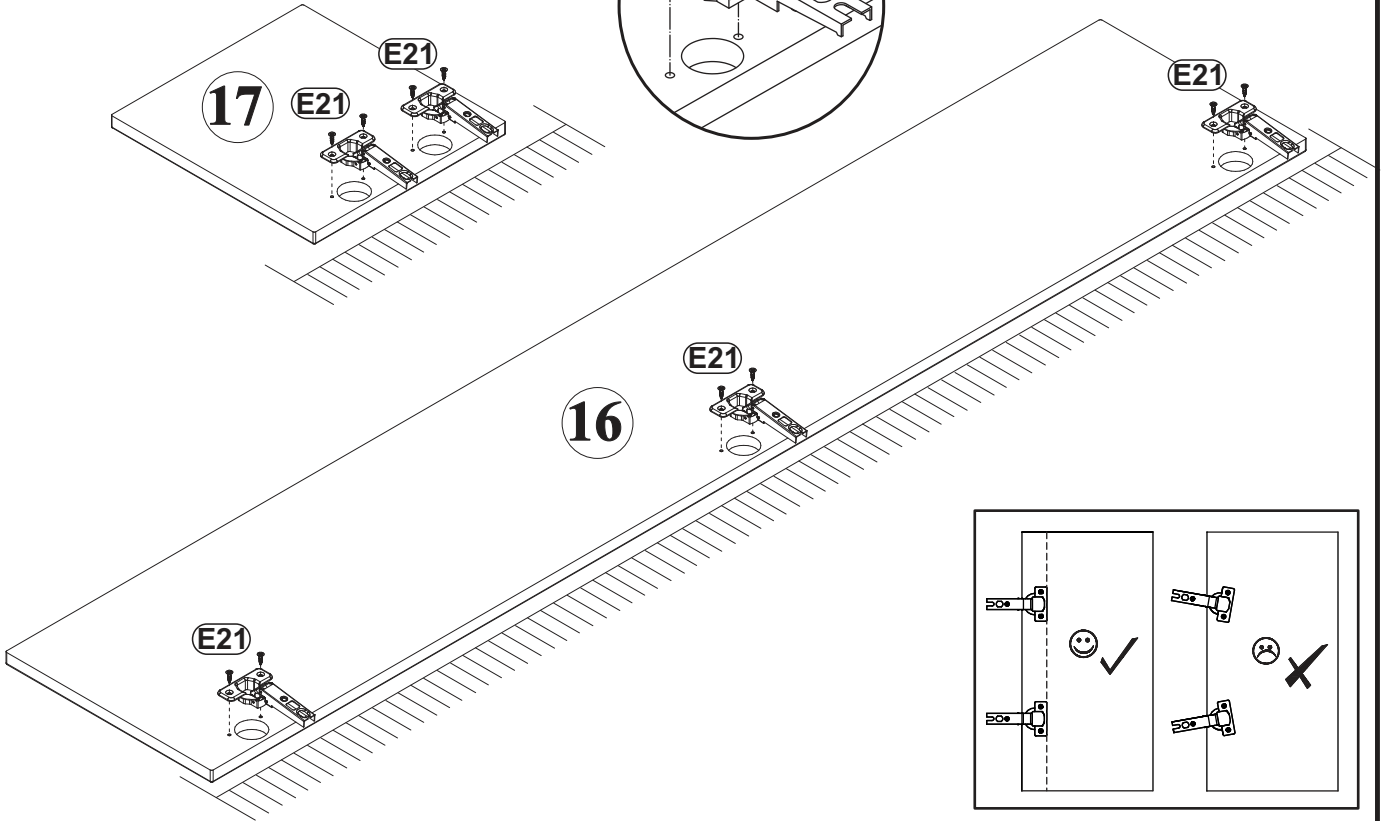
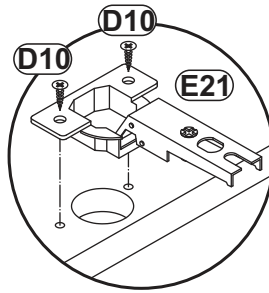

11

|     |     |
|-----|-----|
| E21 | Ø35 |
| x4  | H=0 |

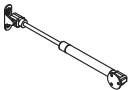
|     |   |
|-----|---|
| BO1 |  |
| x4  |   |

|     |   |
|-----|---|
| D10 |  |
| x16 | USØ3,5x13   |

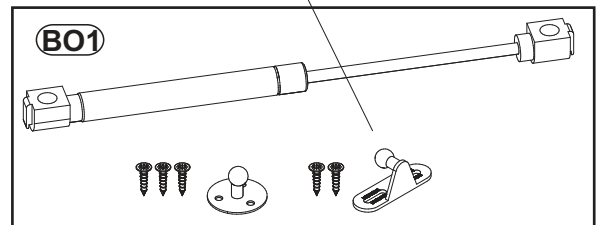
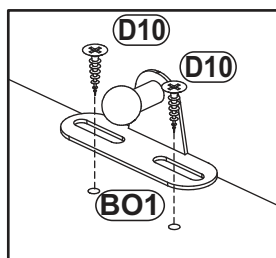
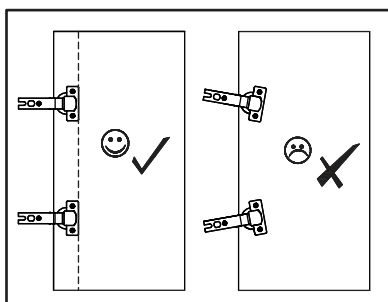
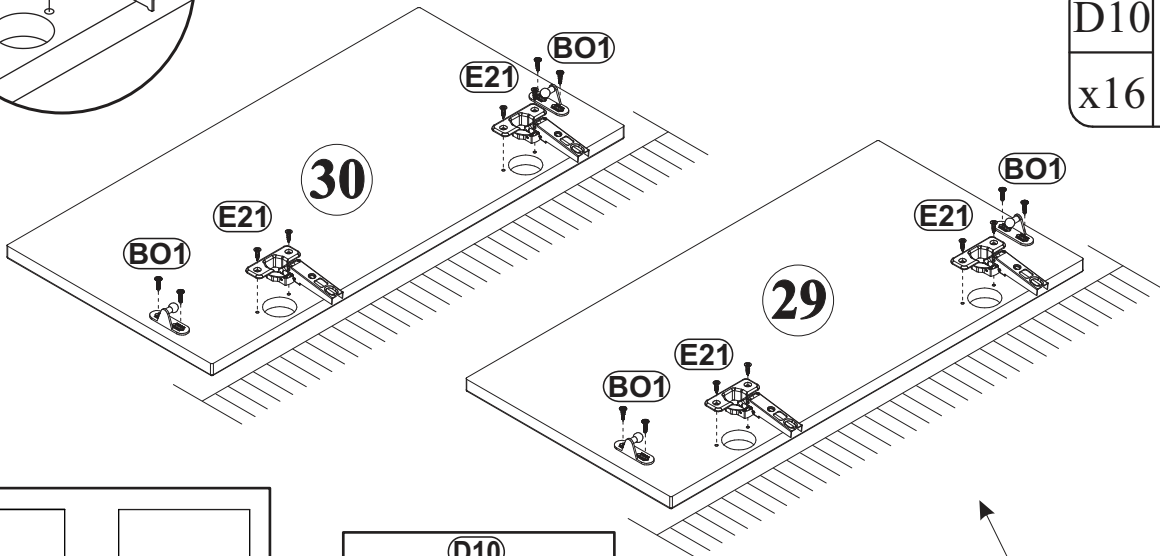
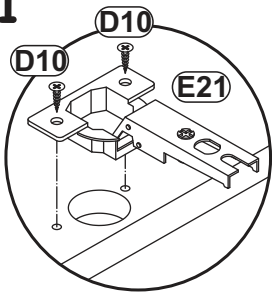

12

|    |   |
|----|---|
| P2 |  |
| x4 |   |

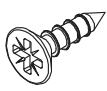
|     |   |
|-----|---|
| D10 |  |
| x6  | USØ3,5x13   |

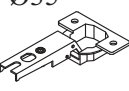
|     |   |
|-----|---|
| E21 |  |
| x3  | Ø35<br>H=0  |

|      |   |
|------|---|
| UP13 |  |
| x4   | UPØ3x16   |

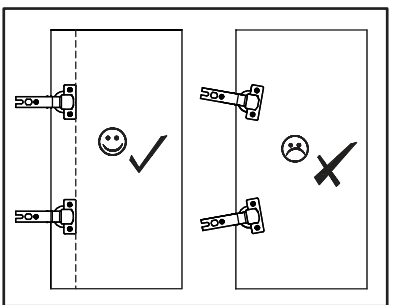
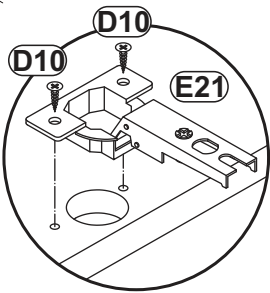
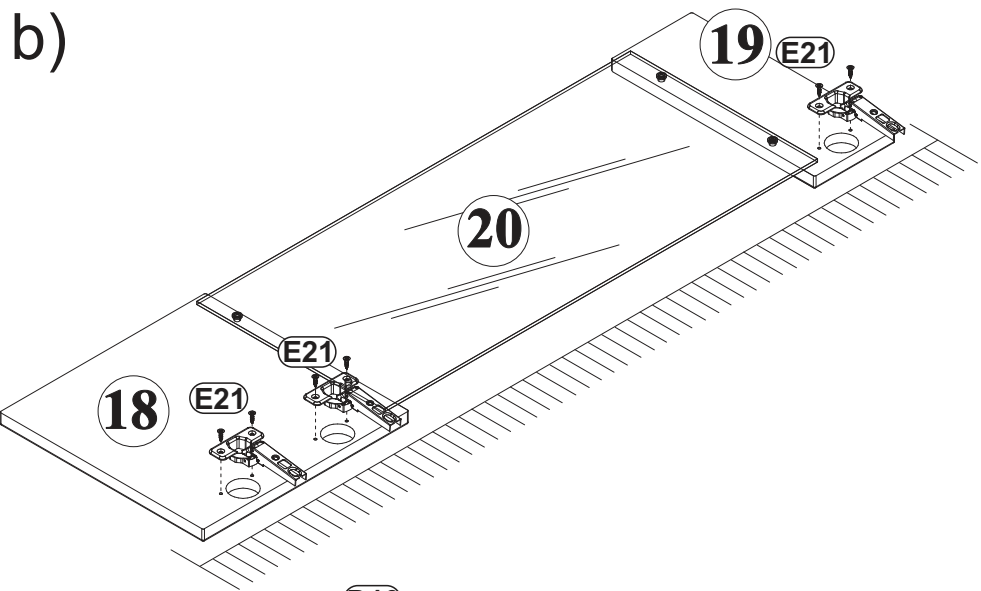
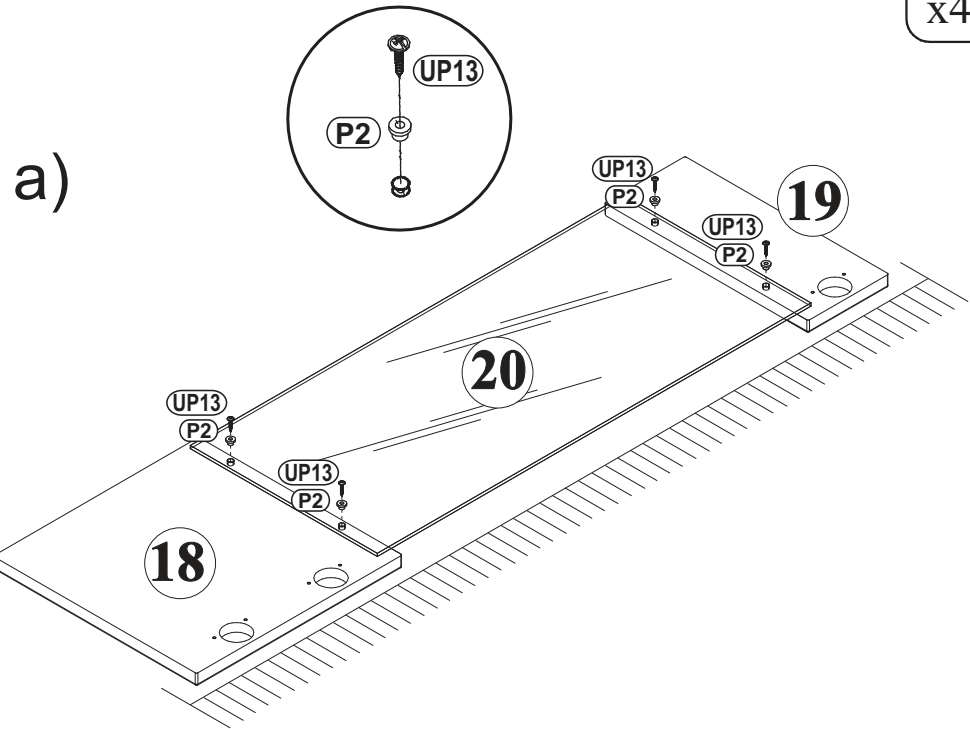

13

|    |   |
|----|---|
| B6 |  |
| x6 | Ø7x76   |

|     |   |
|-----|---|
| G5  |  |
| x14 |   |

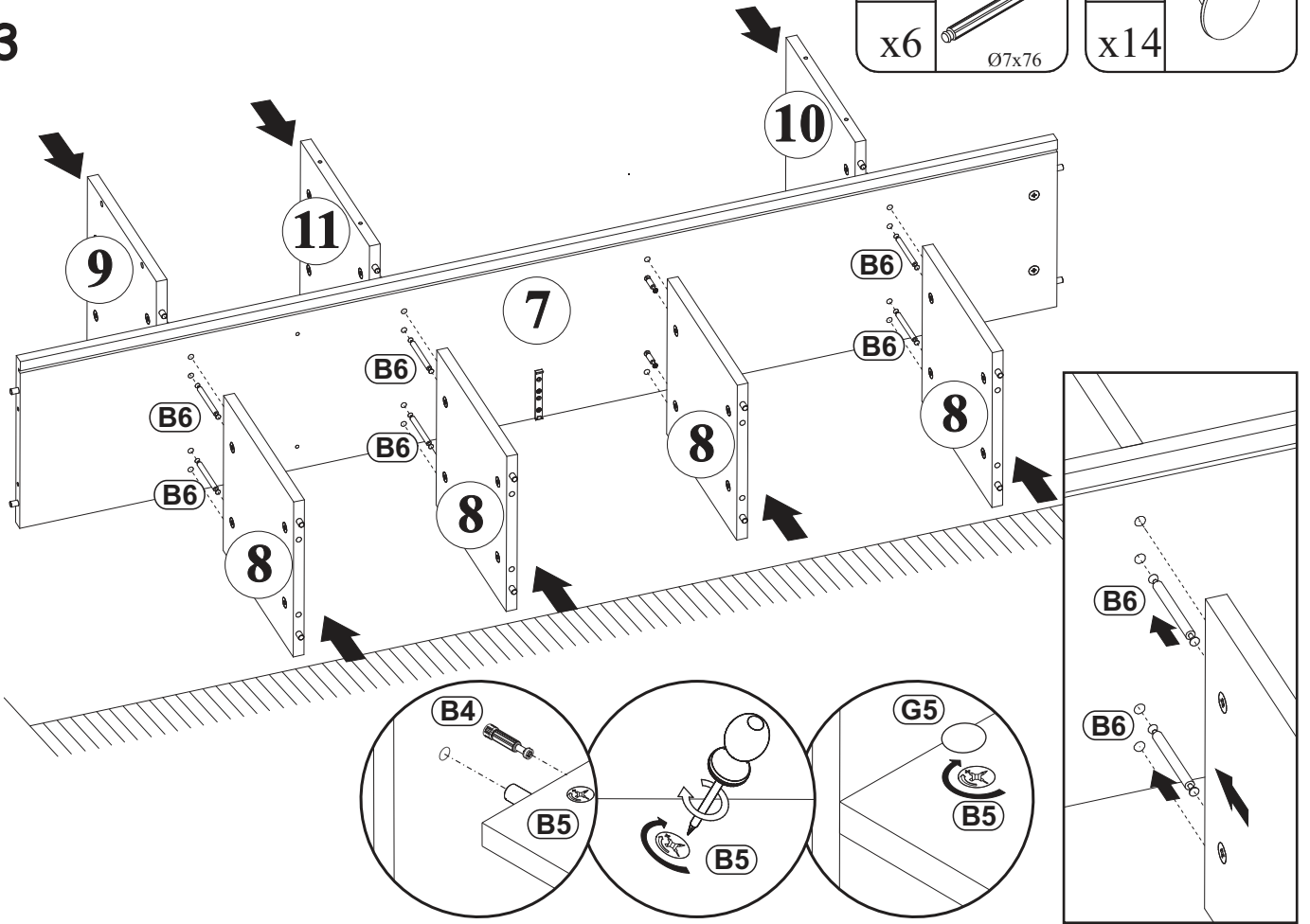

14

|     |   |
|-----|---|
| B11 |  |
| x4  | Ø7x50   |

|    |   |
|----|---|
| G4 |  |
| x4 |   |

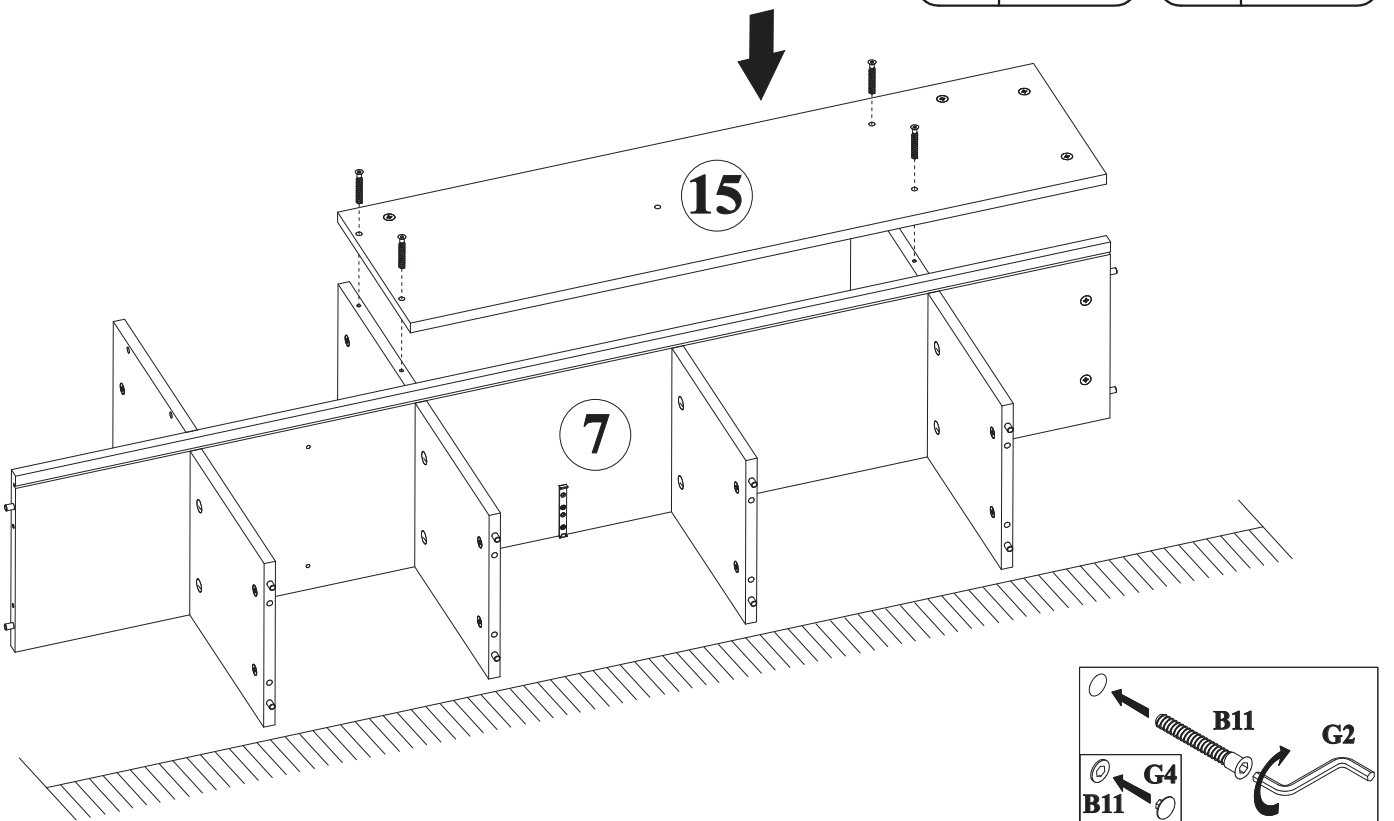

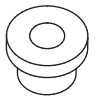

15

|      |   |    |   |
|------|---|----|---|
| UP13 |  | P2 |  |
| x4   | UPØ3x16   | x4 |   |

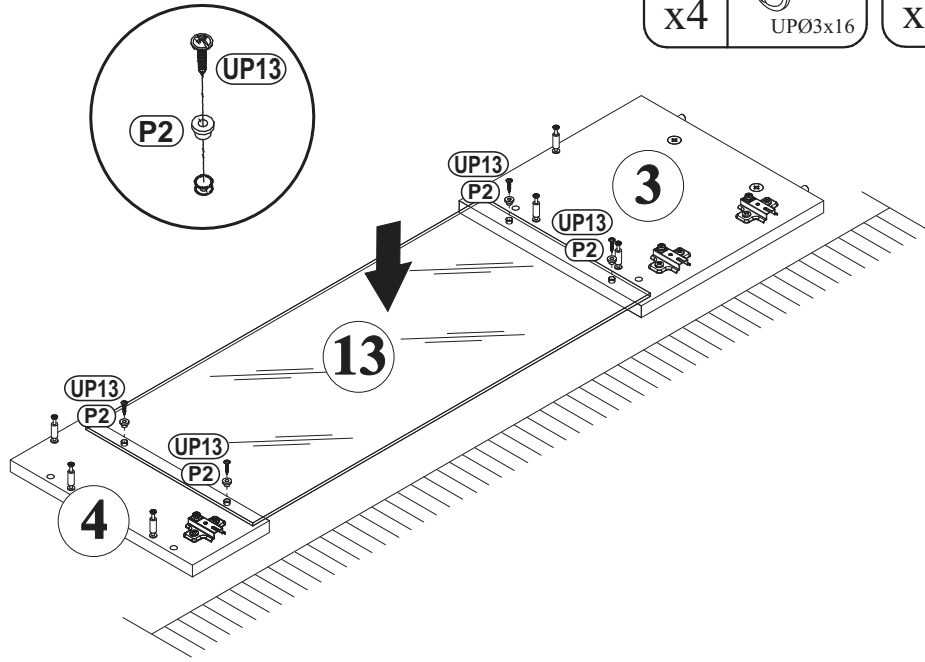

16

|     |  |
|-----|--|
| G5  |  |
| x16 |  |

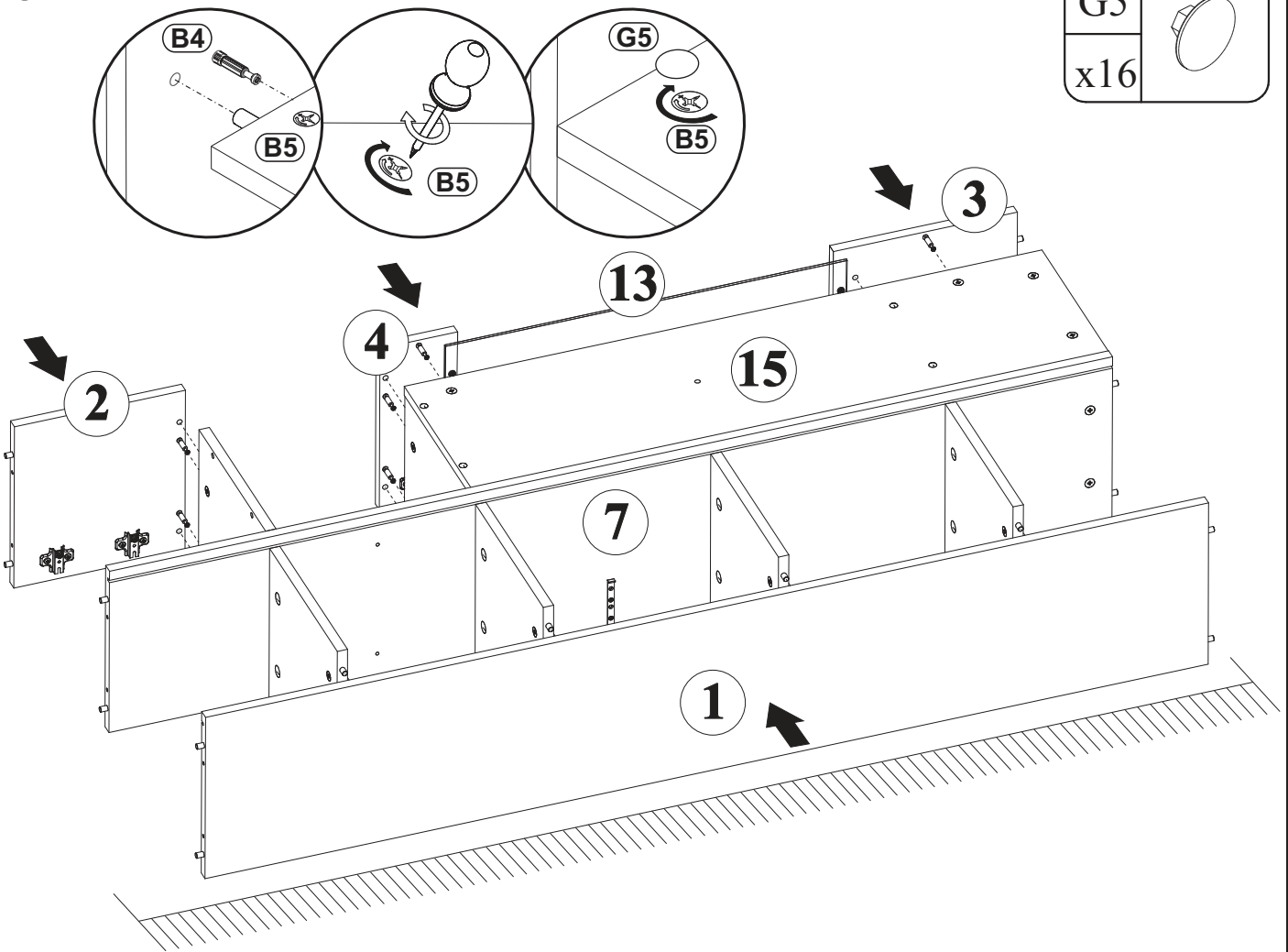



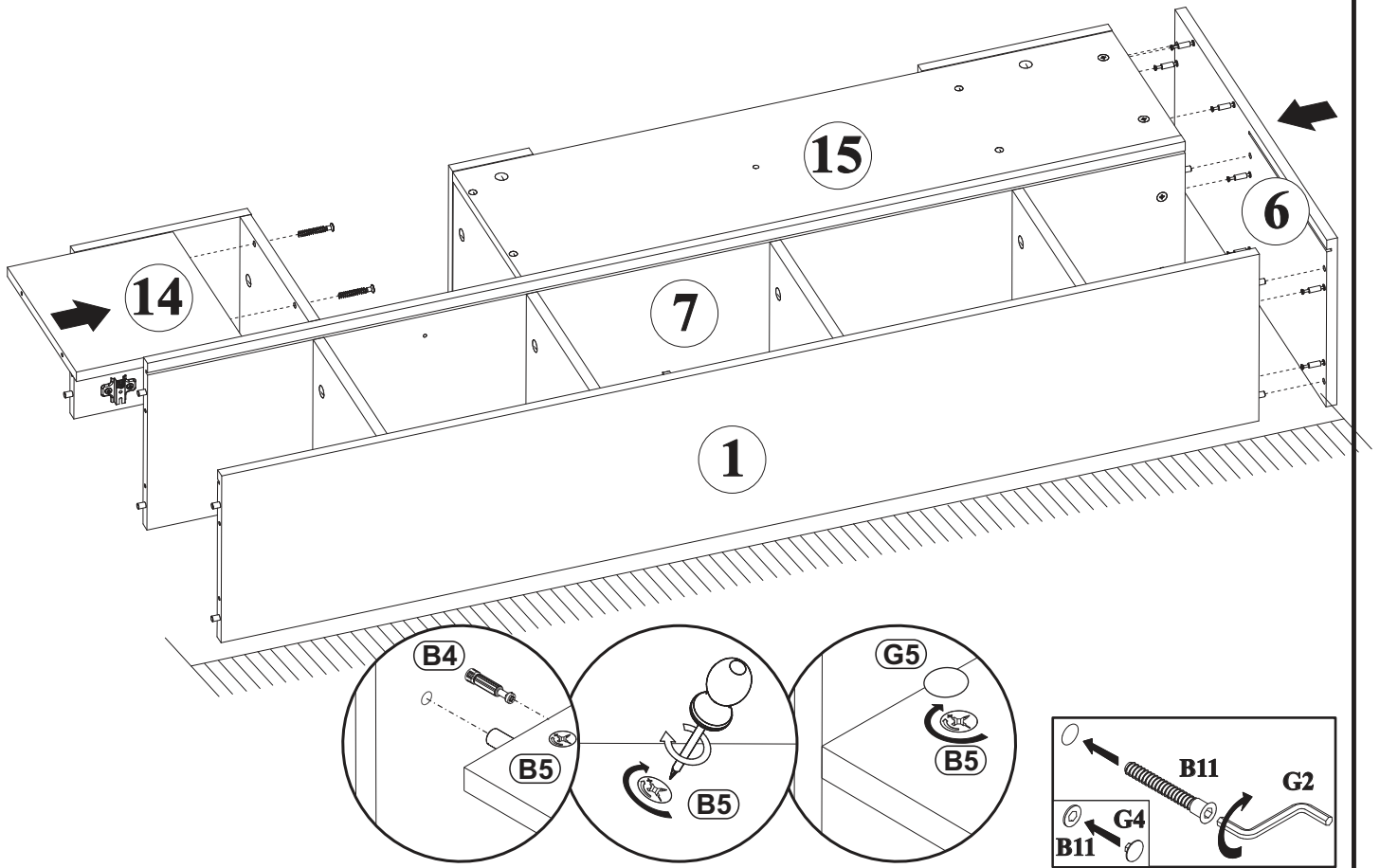
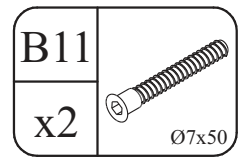
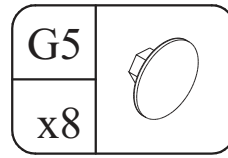

17

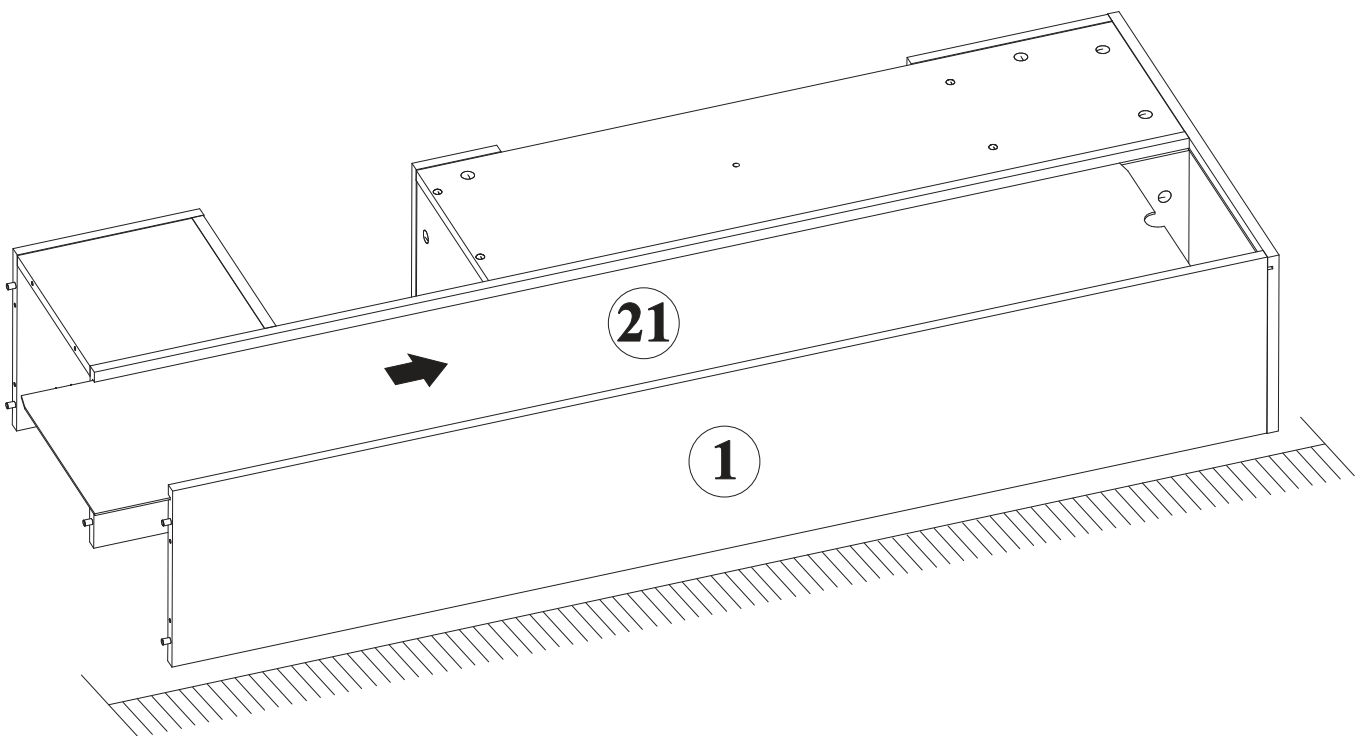

18



19

|     |   |    |   |
|-----|---|----|---|
| B11 |  | G4 |  |
| x8  | Ø7x50   | x8 |   |

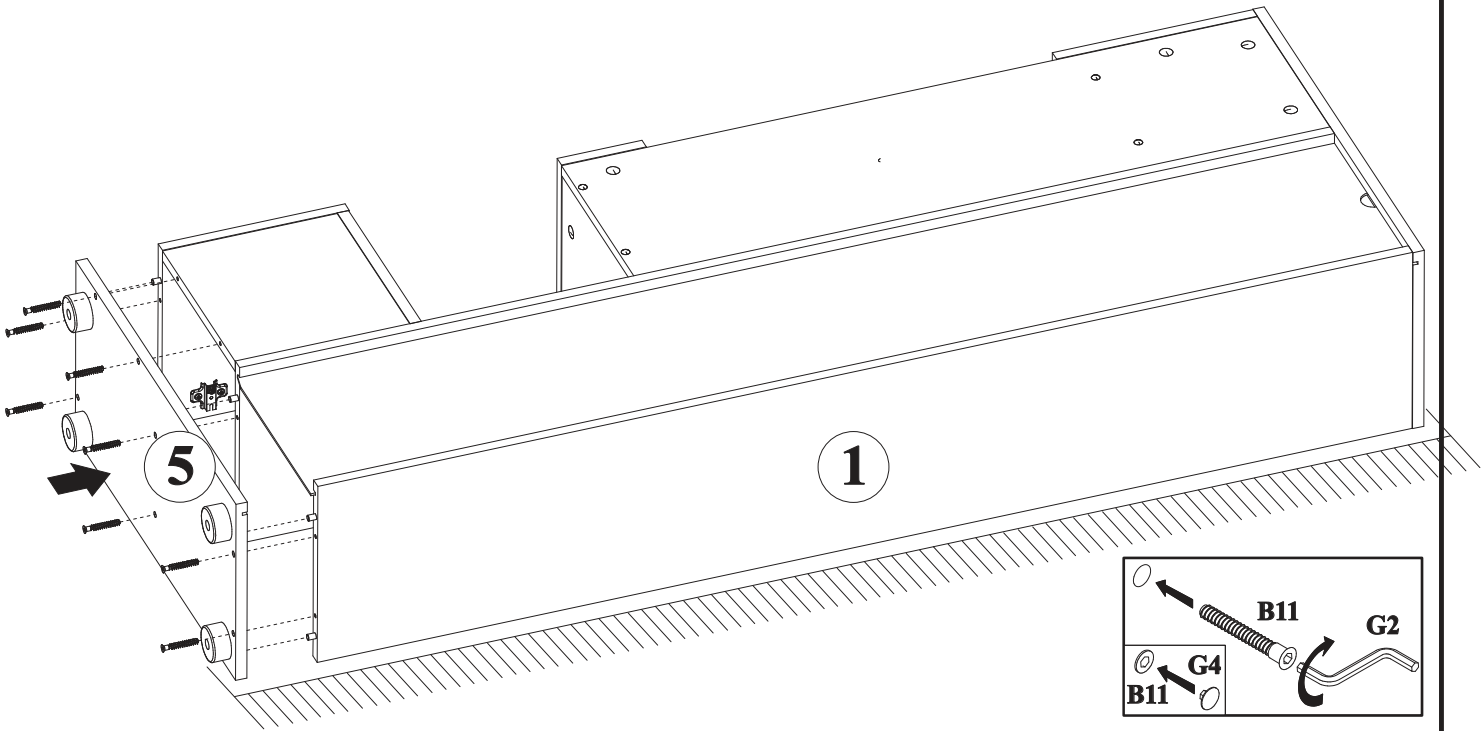

20

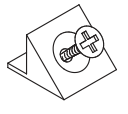
|      |   |     |   |
|------|---|-----|---|
| UP13 |  | S1  |  |
| x8   | UPØ3x16   | x12 |   |

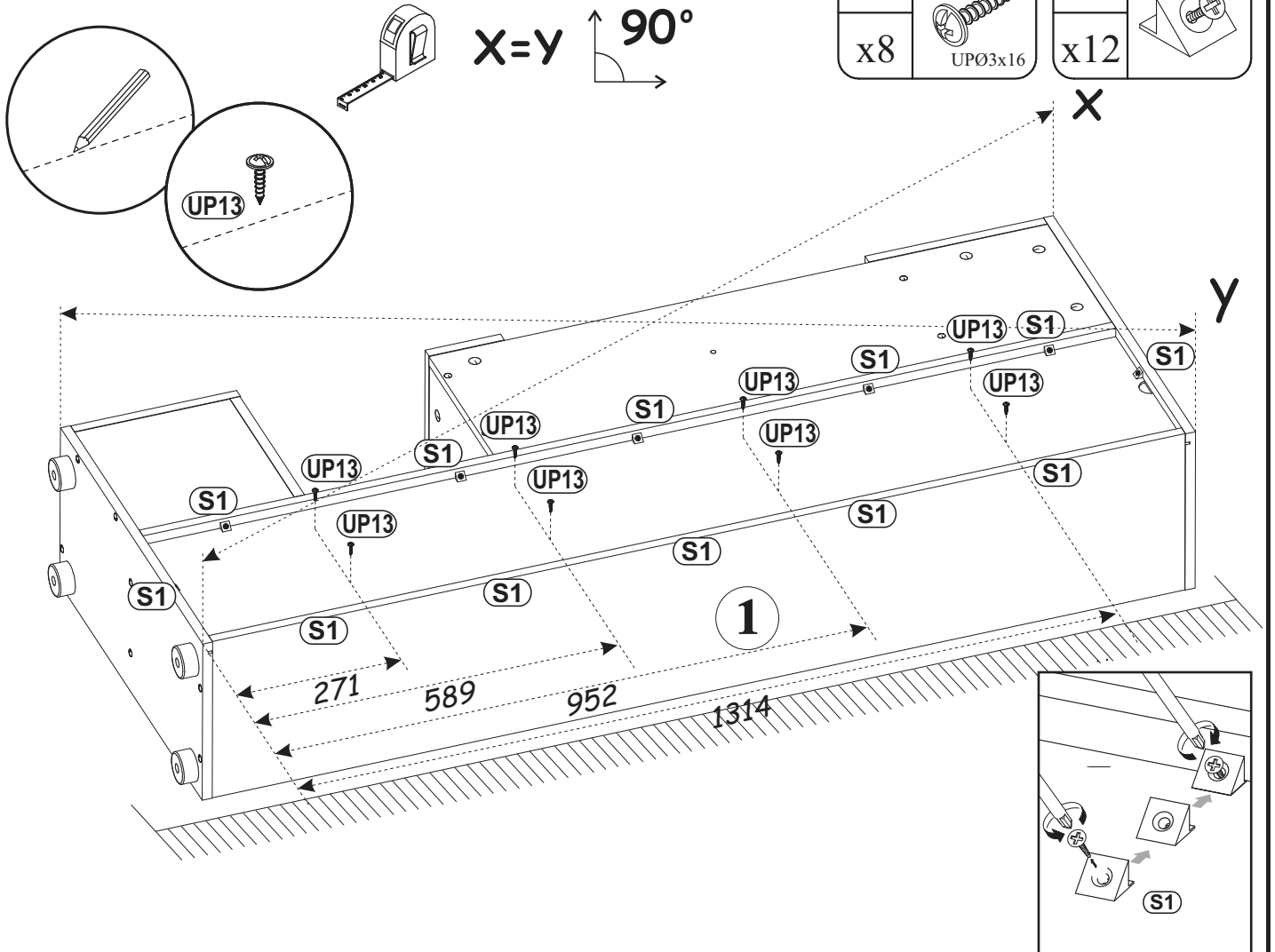

21

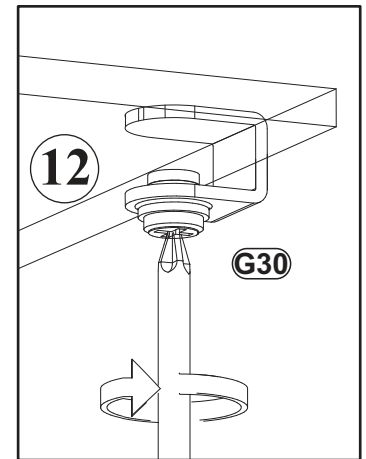
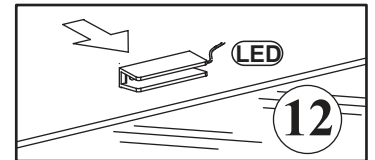
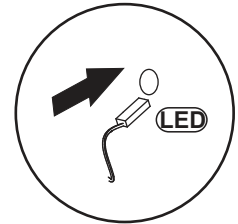
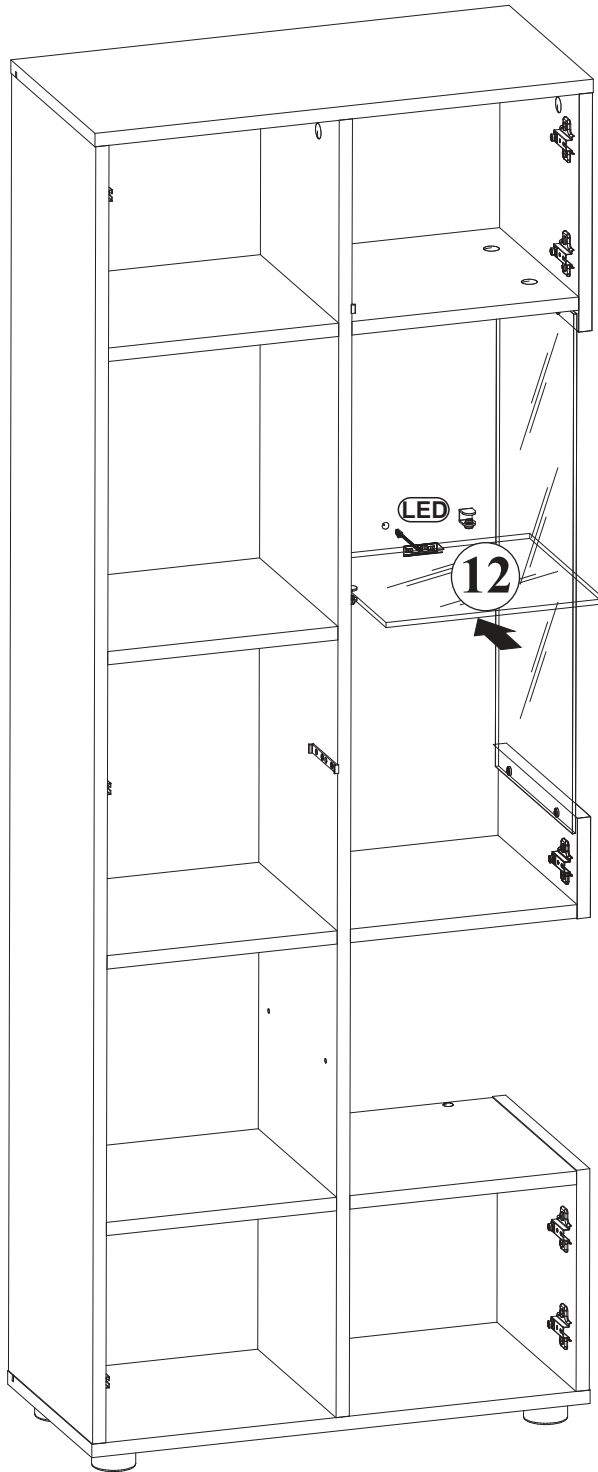
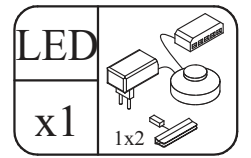

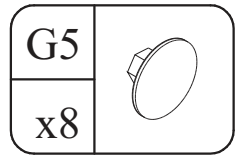

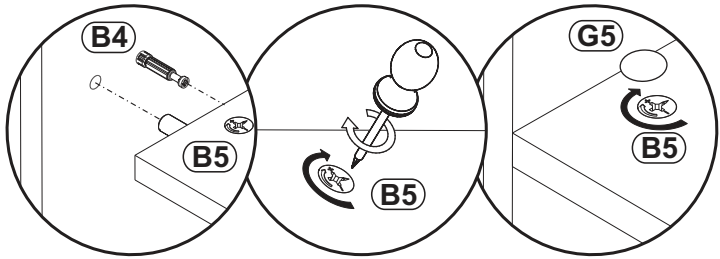
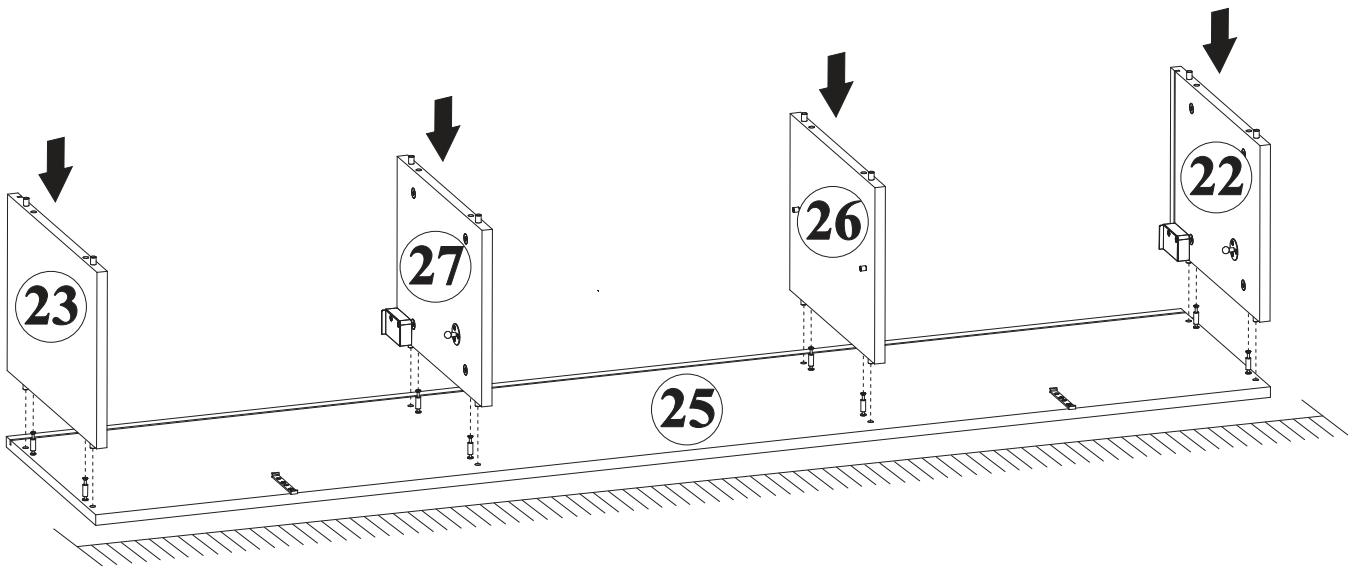

22

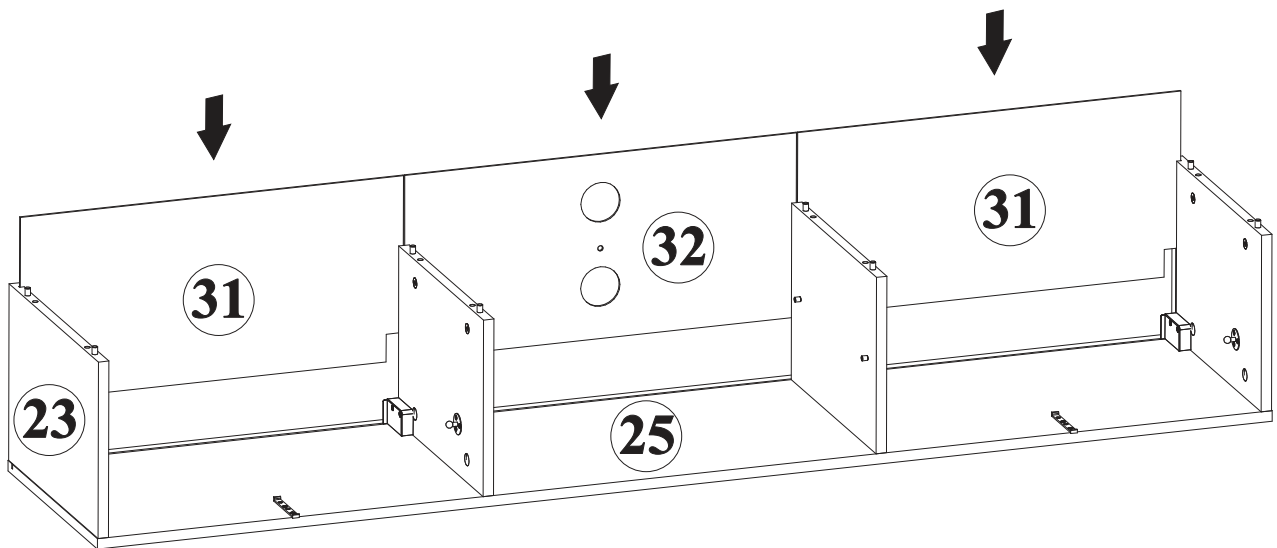

23



24

|    |   |
|----|---|
| G5 |  |
| x8 |   |

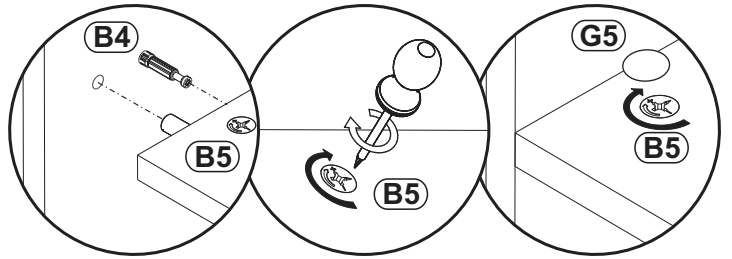
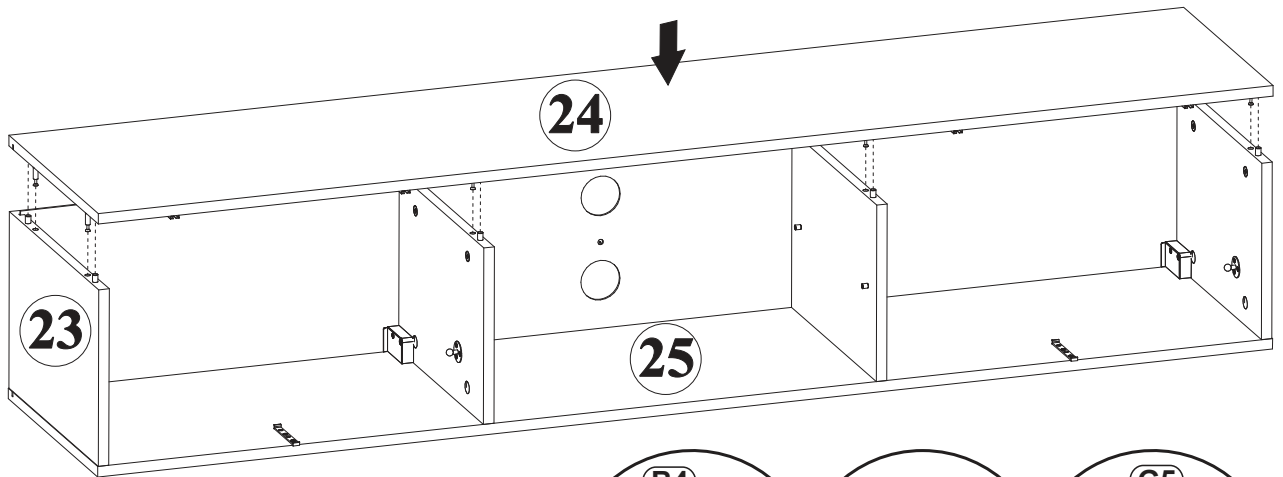

25

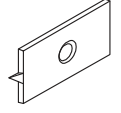

|     |  |
|-----|--|
| G16 |  |
| x4  |  |

|      |   |
|------|---|
| UP13 |  |
| x4   | UPØ3x16   |

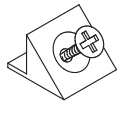
|     |   |
|-----|---|
| S1  |  |
| x14 |   |

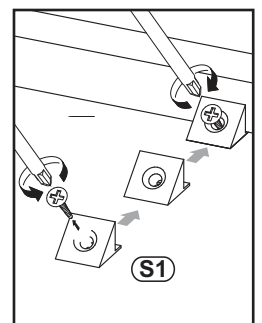
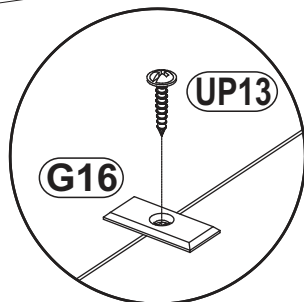
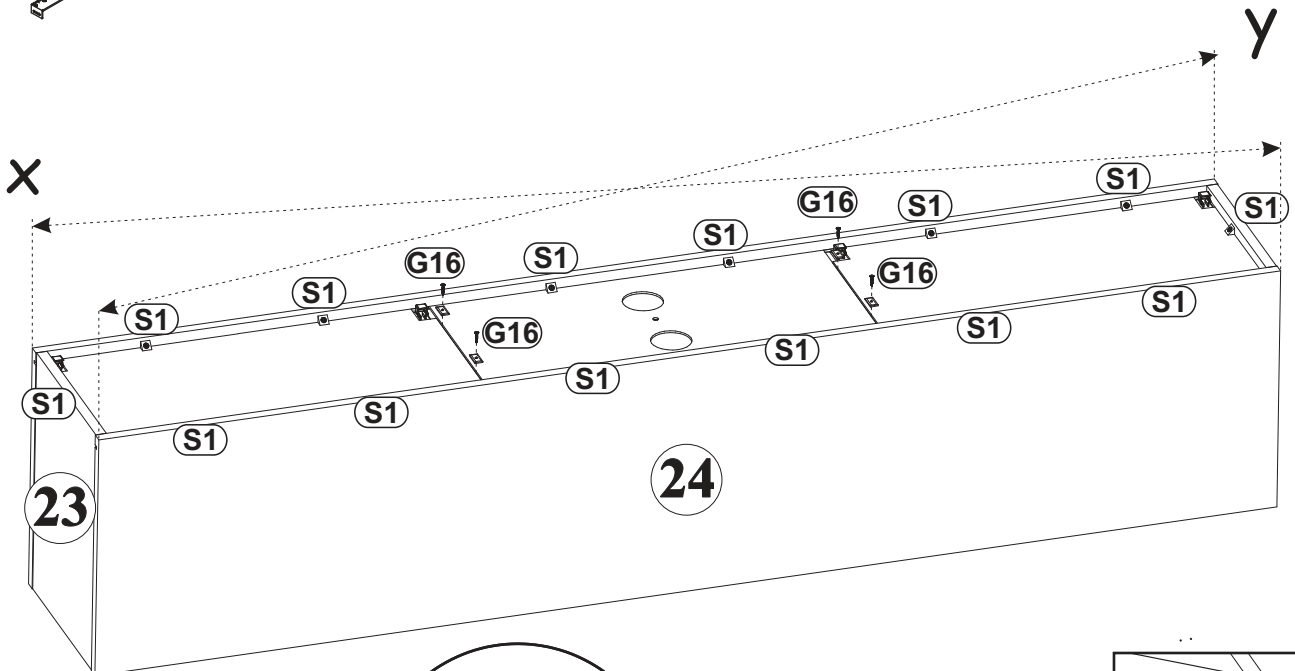

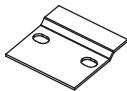
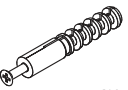
|     |   |     |   |     |   |
|-----|---|-----|---|-----|---|
| LED |  | SZ7 |  | KR1 |  |
| x1  | 1x2   | x4  |   | X8  | Ø8  |

26

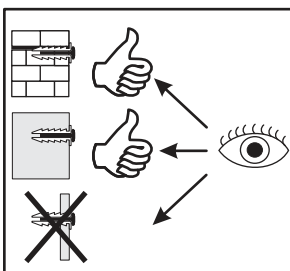
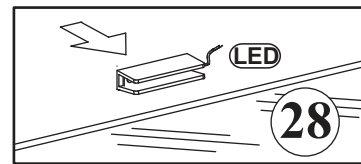
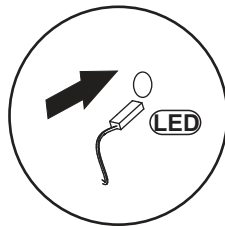
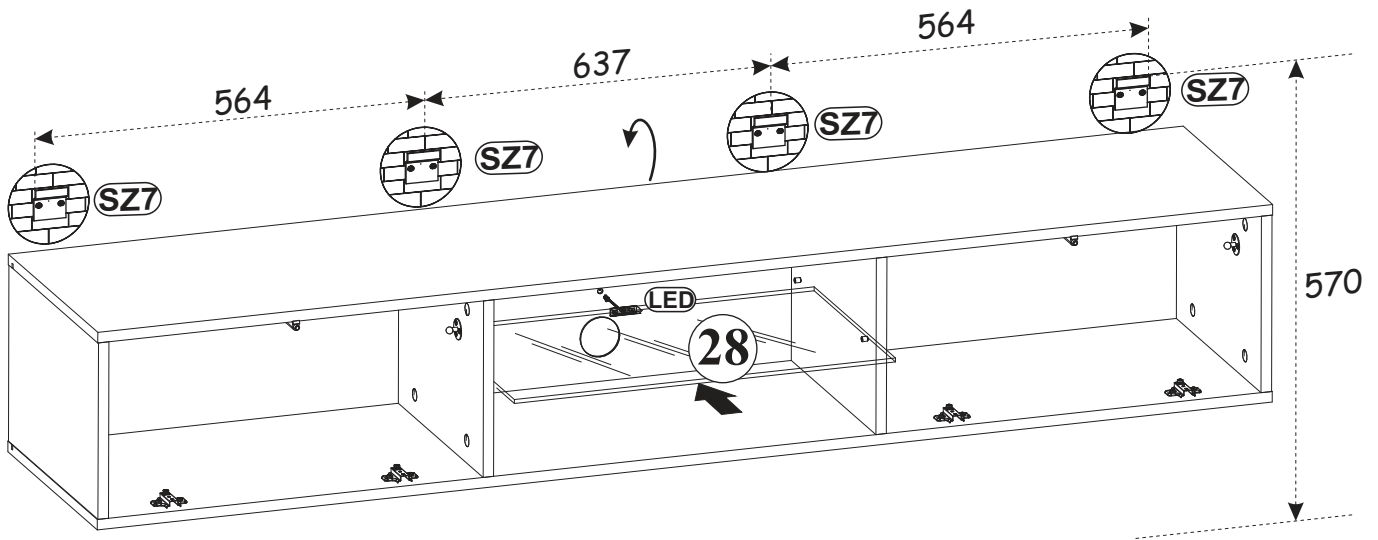
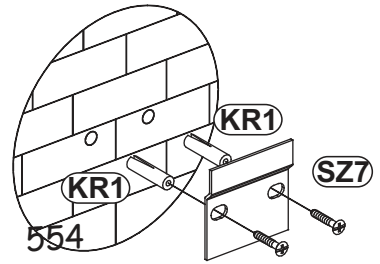
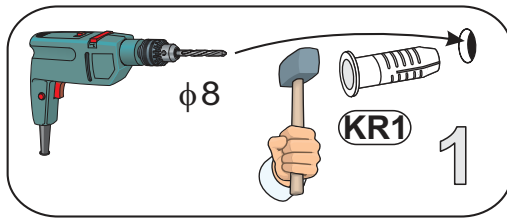

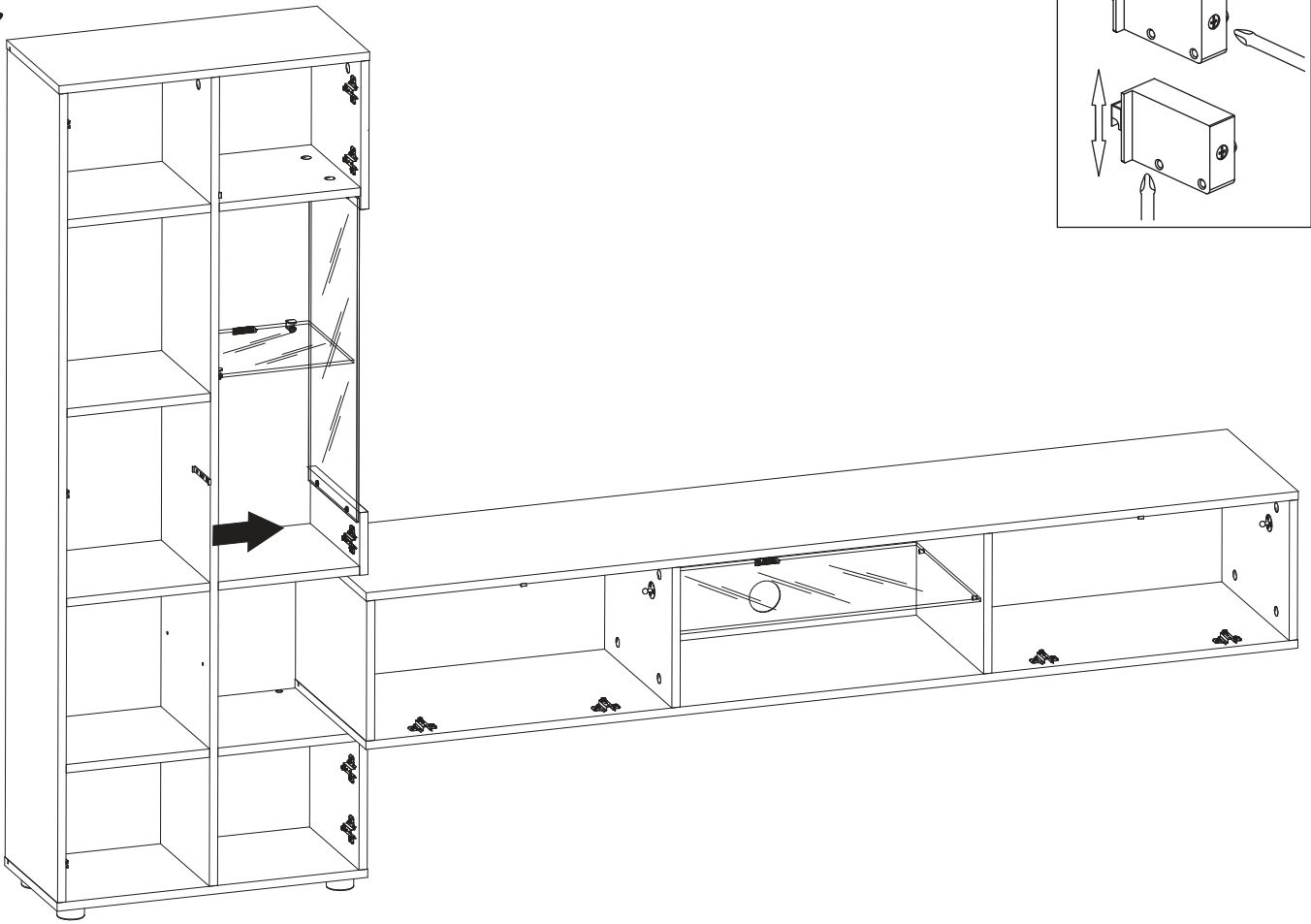

27

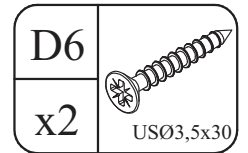
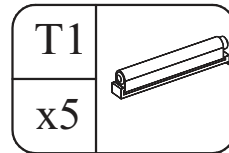
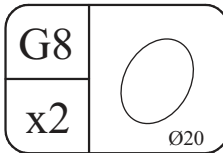
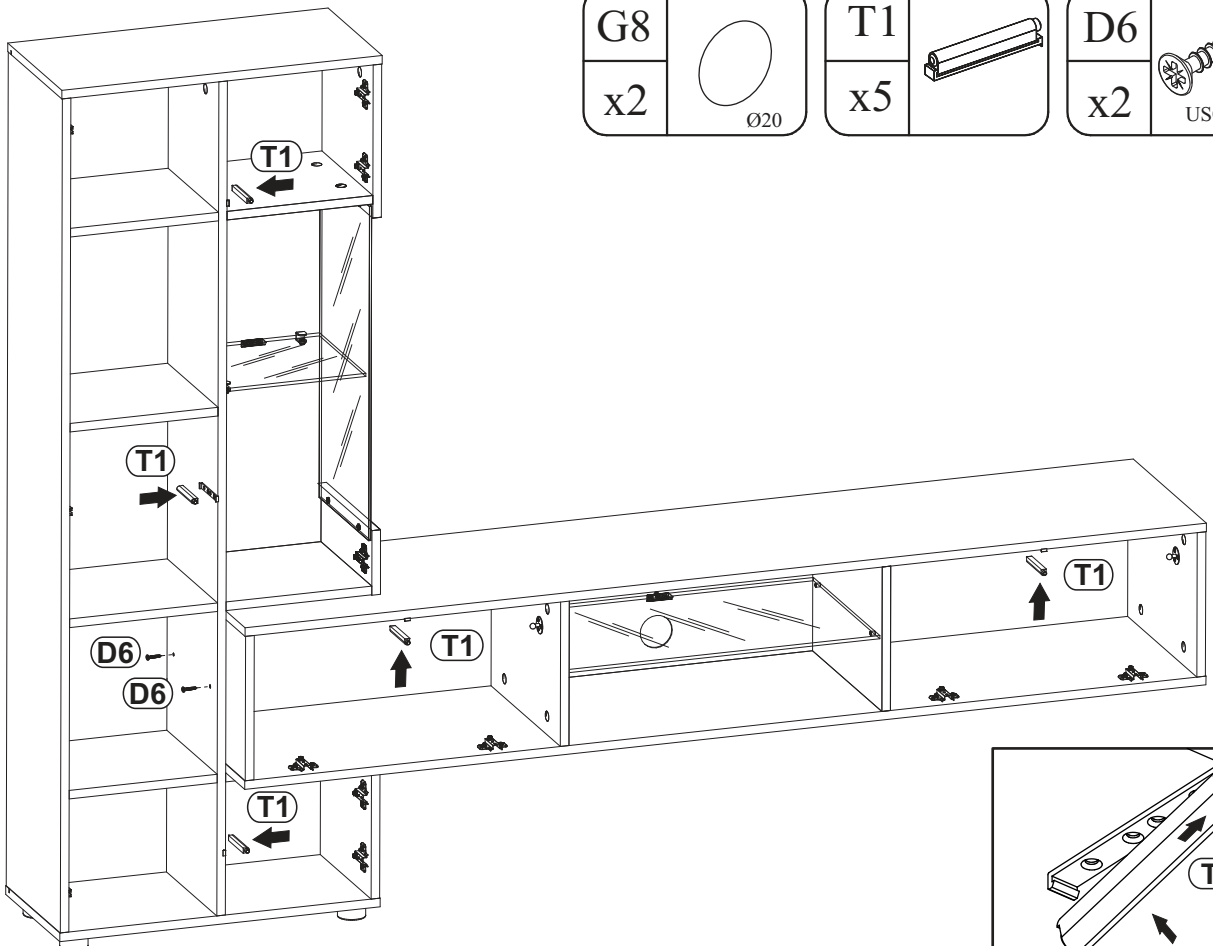

28

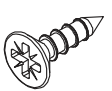
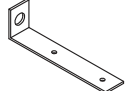

|     |  |    |   |     |   |
|-----|--|----|---|-----|---|
| D10 |  | L1 |  | KR1 |  |
| x2  | USØ3,5x13  | x1 |   | x1  |   |

29

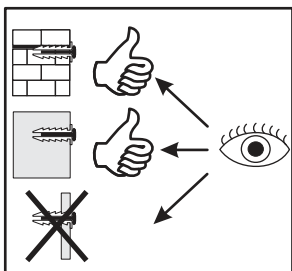
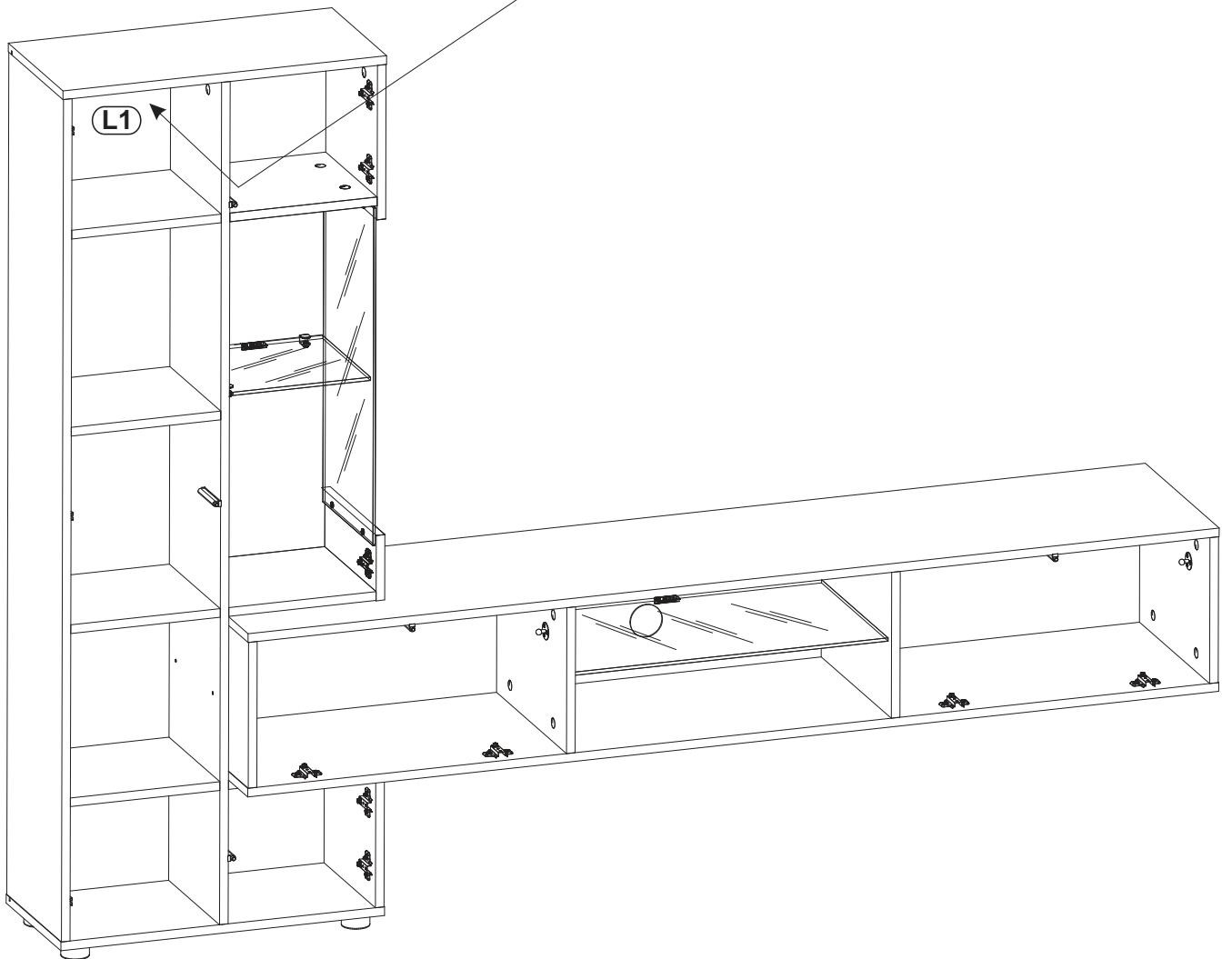
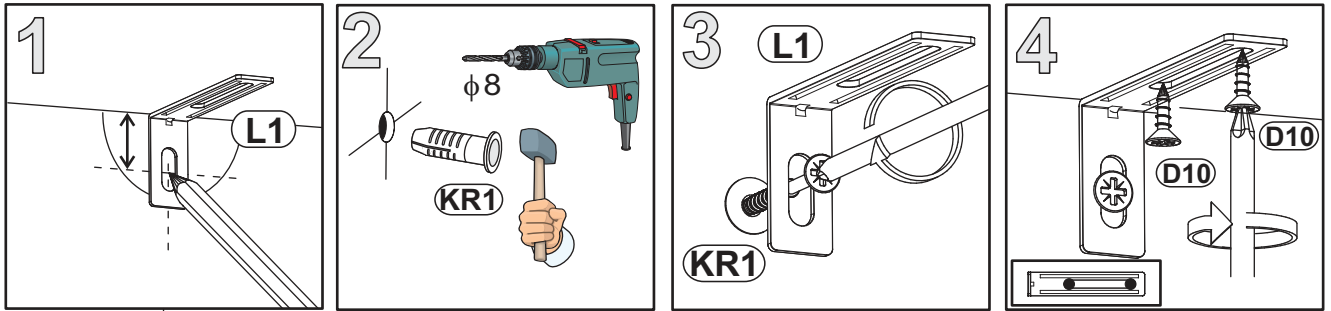



30

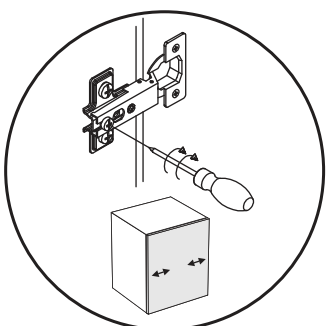
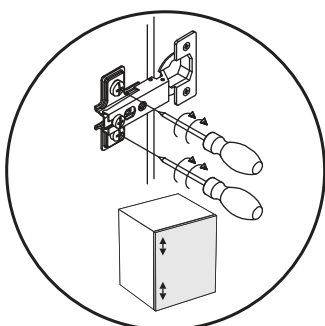
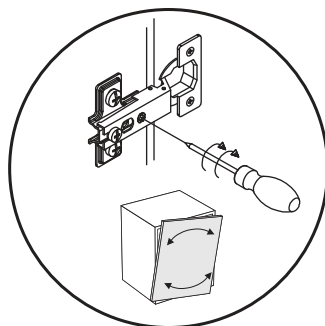
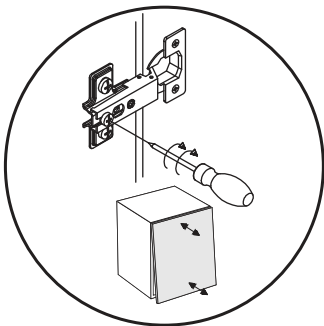
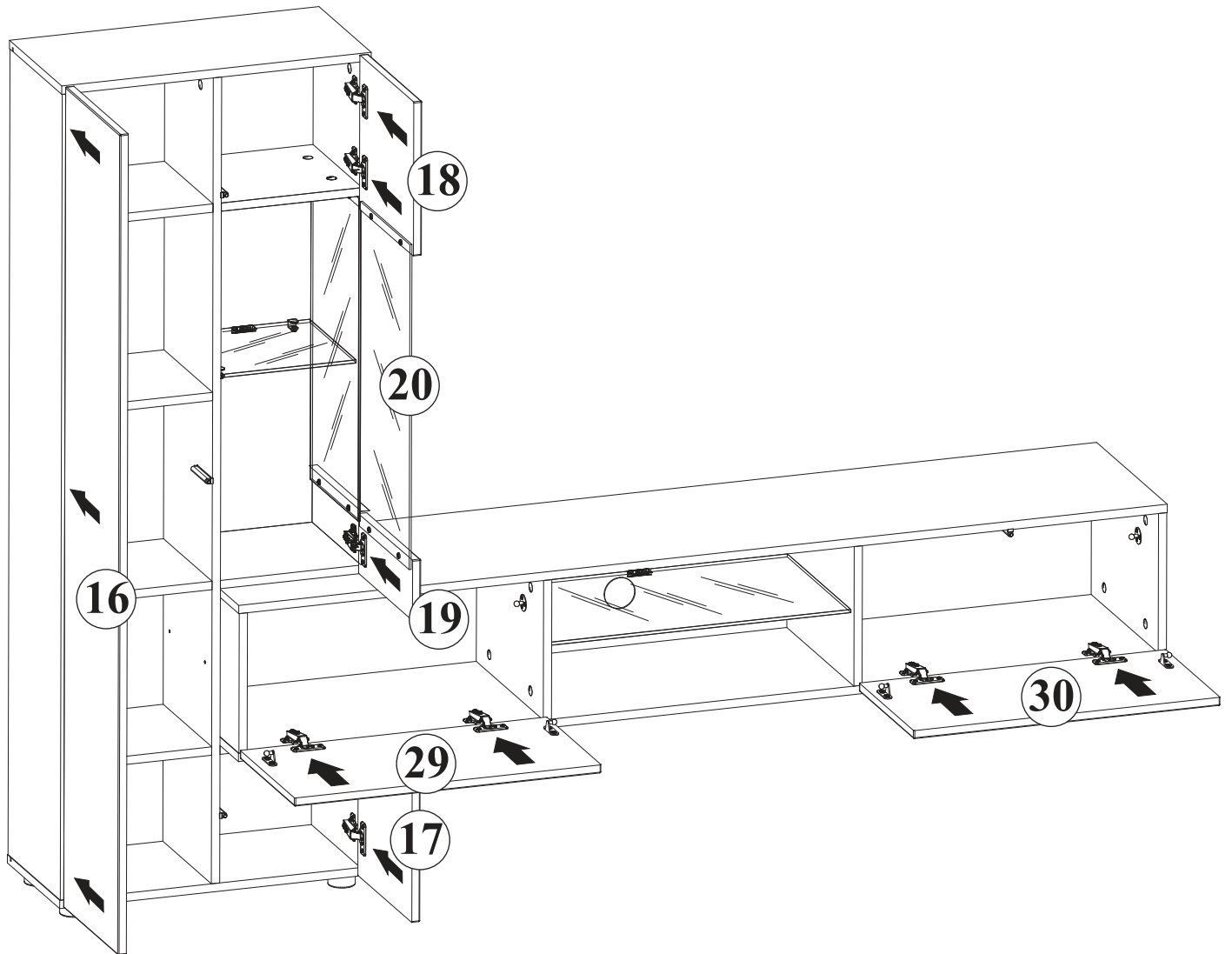

31

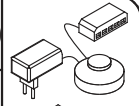
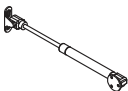
|     |  |     |   |
|-----|--|-----|---|
| LED |  | BO1 |  |
| x1  | 1x2  | x4  |   |

