

AMW 730/IX

12NC: 858773001900

GTIN (EAN) code: 8003437394768

Whirlpool

SENSING THE DIFFERENCE

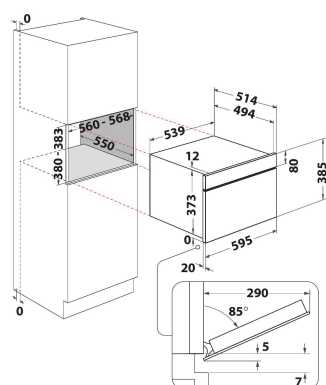

MAIN FEATURES

Product group	Microwave
Commercial code	AMW 730/IX
Main colour of product	Stainless steel
Type of micro-wave oven	MW+Grill function
Construction type	Built-in
Type of control	Electronic
Type of control settings	LCD
Additional cooking method Grill	Ano
Crisp	Ano
Steam	Ne
Additional cooking method Fan cooking	Ne
Clock	Ano
Automatic programmes	Ano
Height of the product	385
Width of the product	595
Depth of the product	468
Minimum niche height	380
Minimum niche width	556
Niche depth	550
Net weight (kg)	27
Cavity capacity (l)	31
Turntable	Ano
Turntable diameter (mm)	325
Integrated Cleaning system	Ne

TECHNICAL FEATURES

Current (A)	10
Voltage (V)	230
Frequency (Hz)	50
Length of Electrical Supply Cord (cm)	135
Plug type	Schuko
Timer	Ne
Grill power (W)	800
Type of grill	Quartz
Cavity material	Stainless steel
Interior light	Ano
Additional cooking method Grill	Ano
Position of interior lights of the cavity	Right side

ENERGETICKÝ ŠTÍTEK

6th Sense / Dynamic Intelligence	6. smysl
Number of power levels	7
Maximum micro-wave power (W)	1000
Bread Defrost	Ne
Jet Defrost	Ano
Jet Start	Ano