

Art. No 0020017744

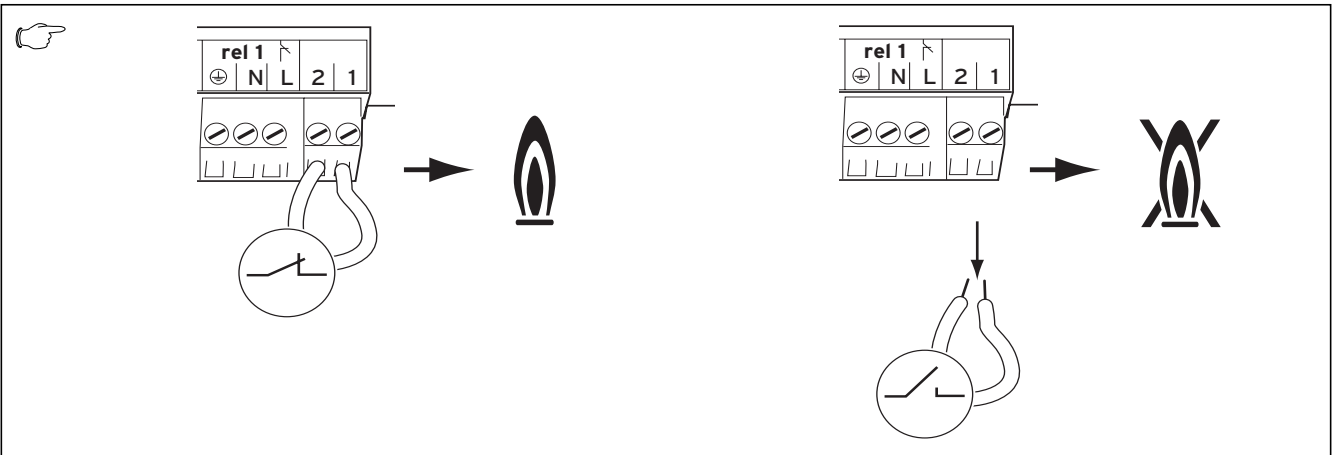

Multifunktionsmodul 2 aus 7
Multifunctional module 2 in 7

VR 40

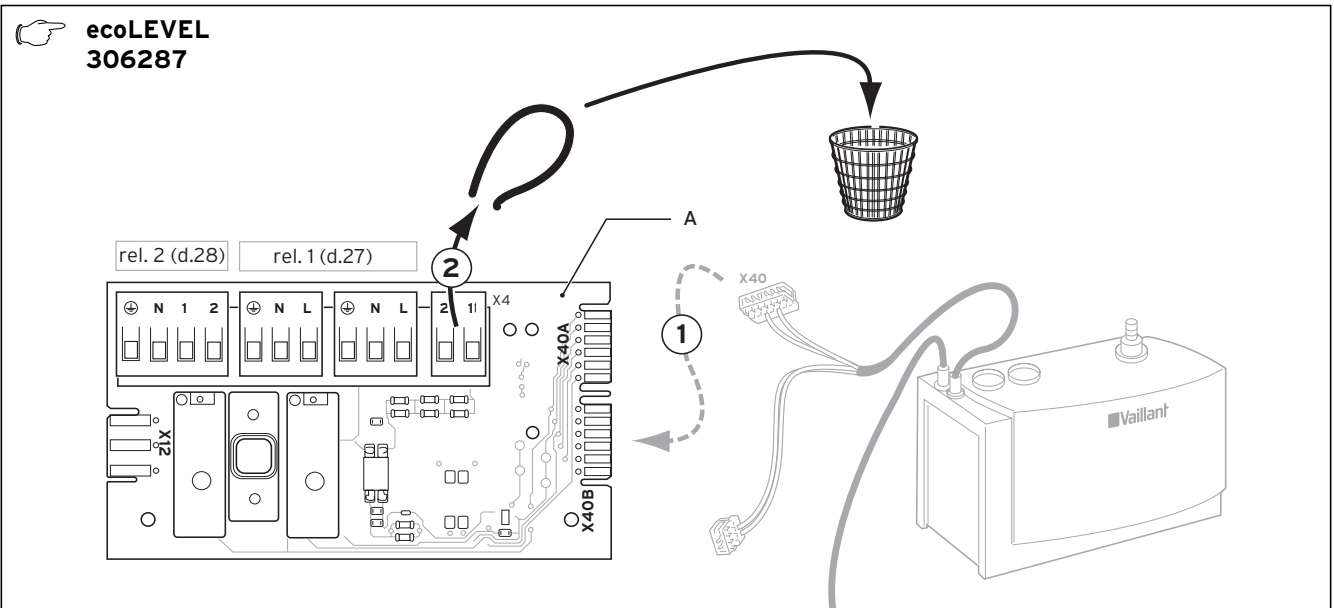
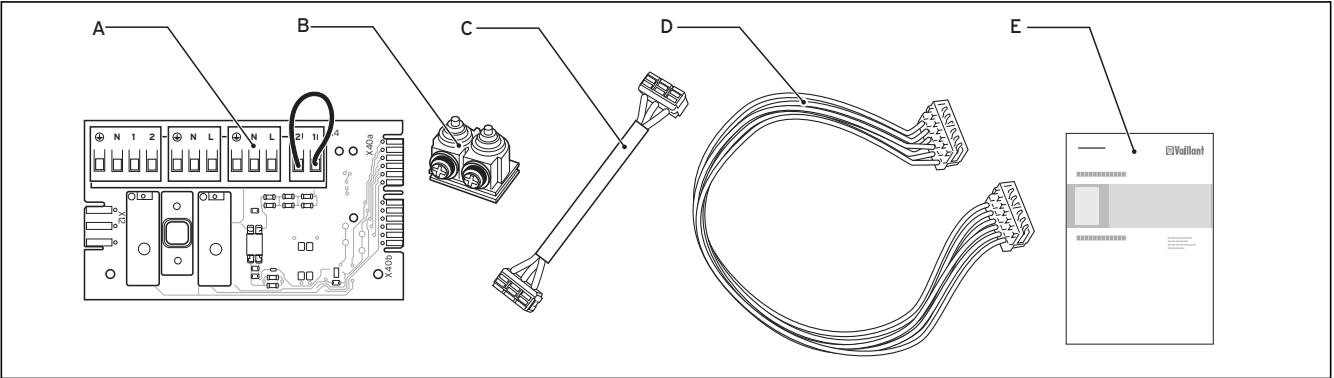

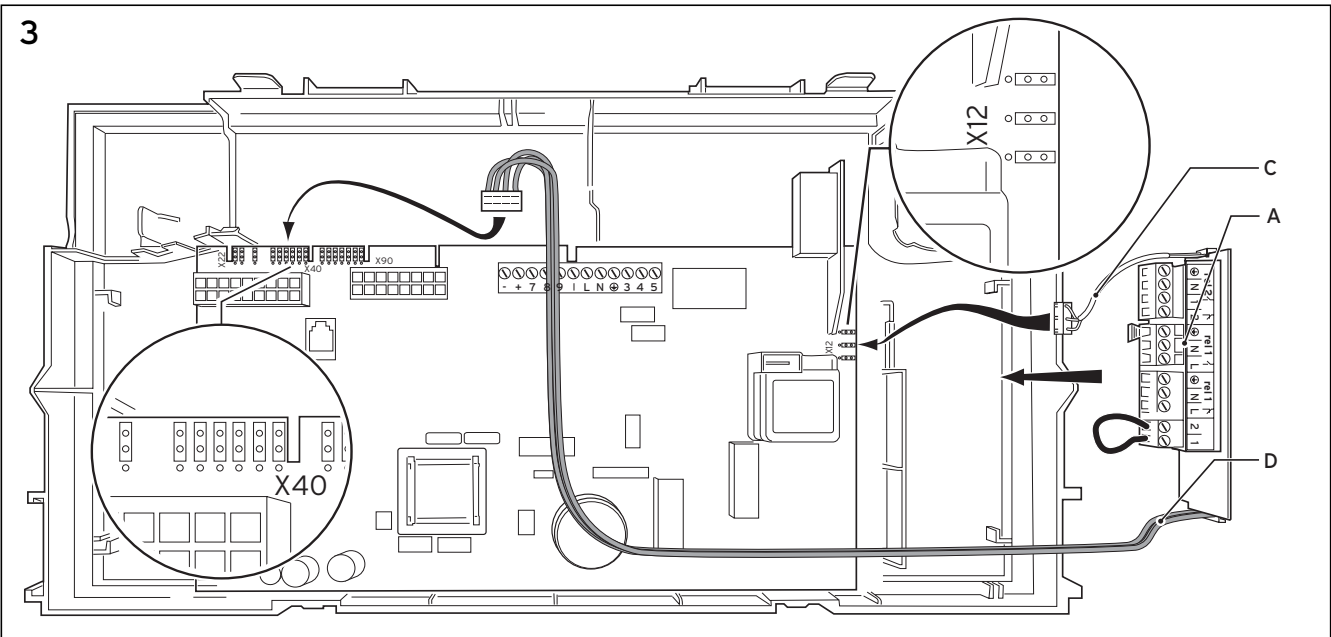
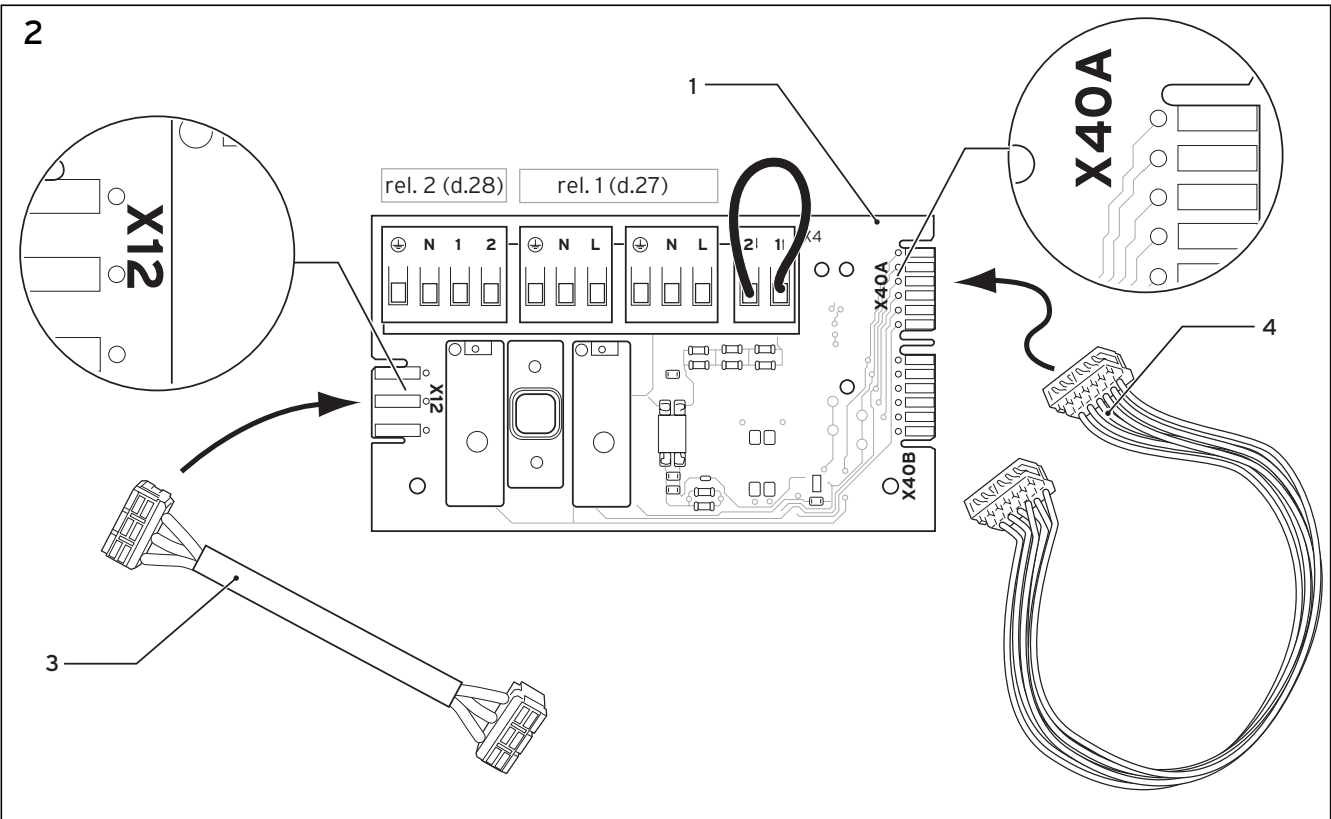
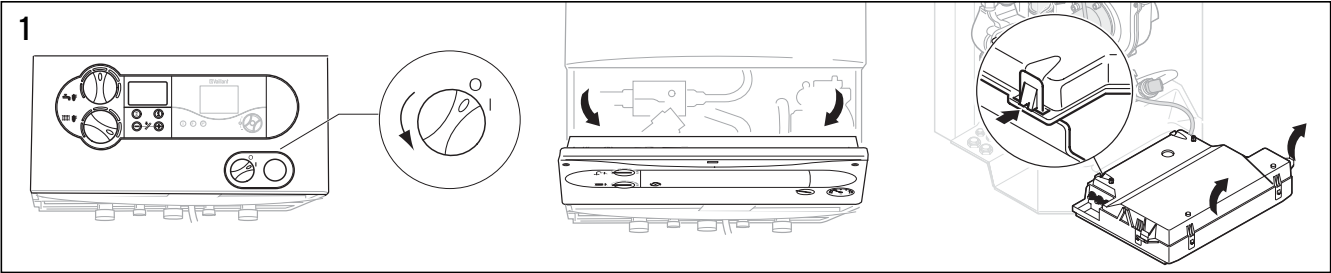

4

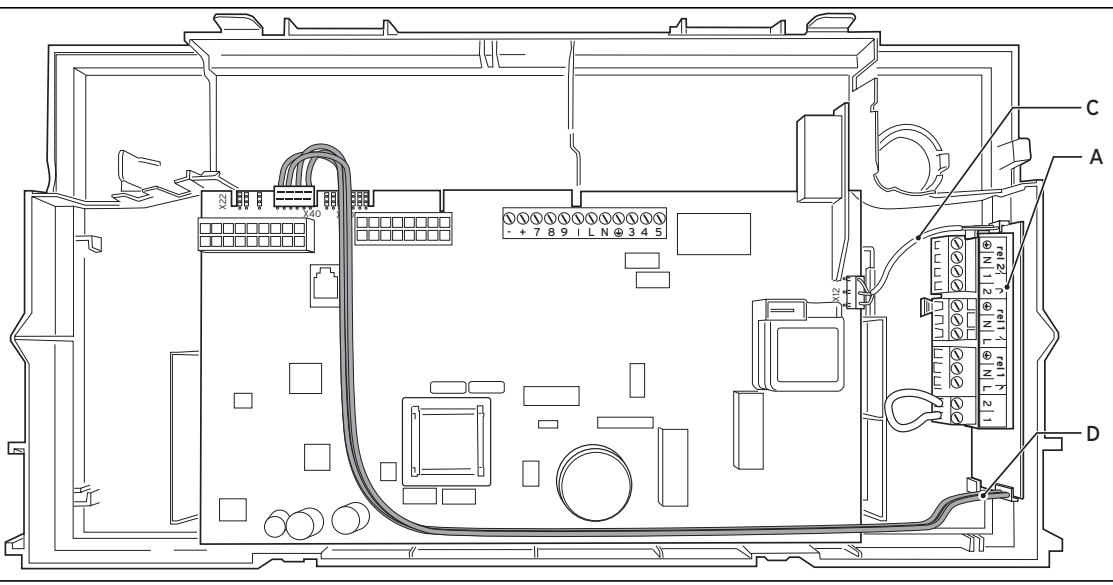

5

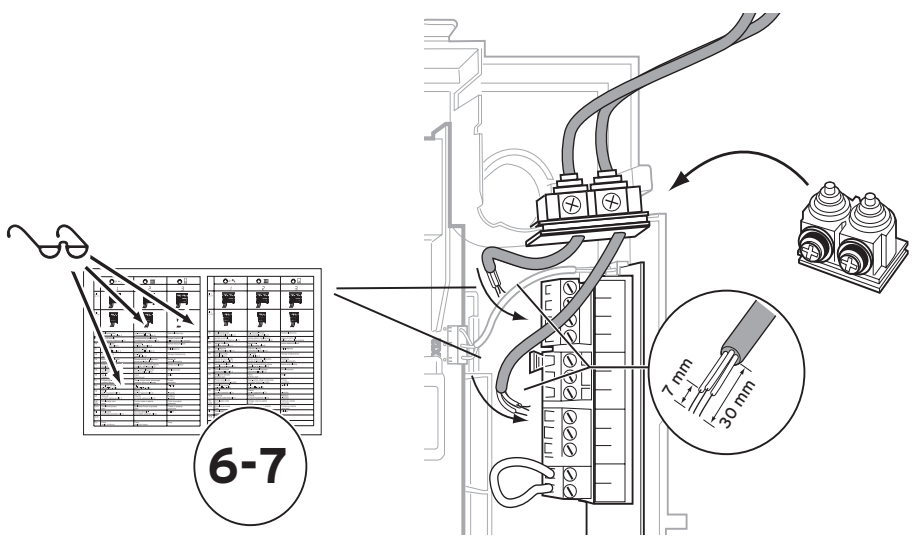

6

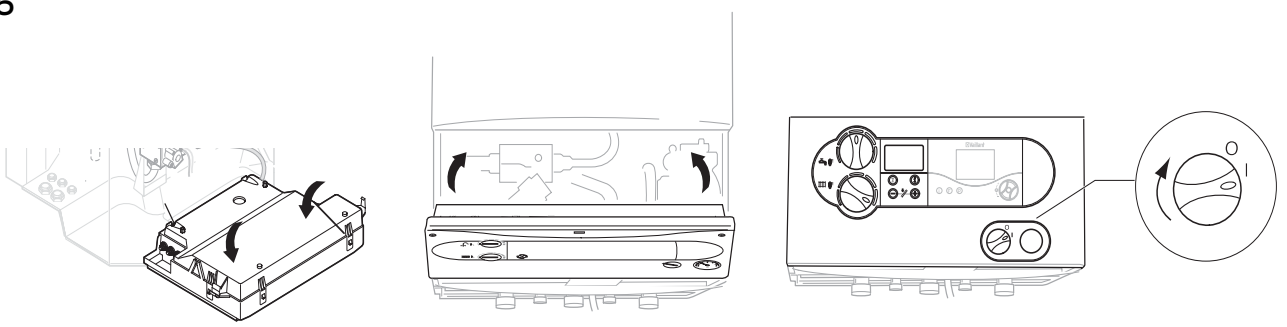



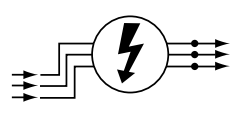

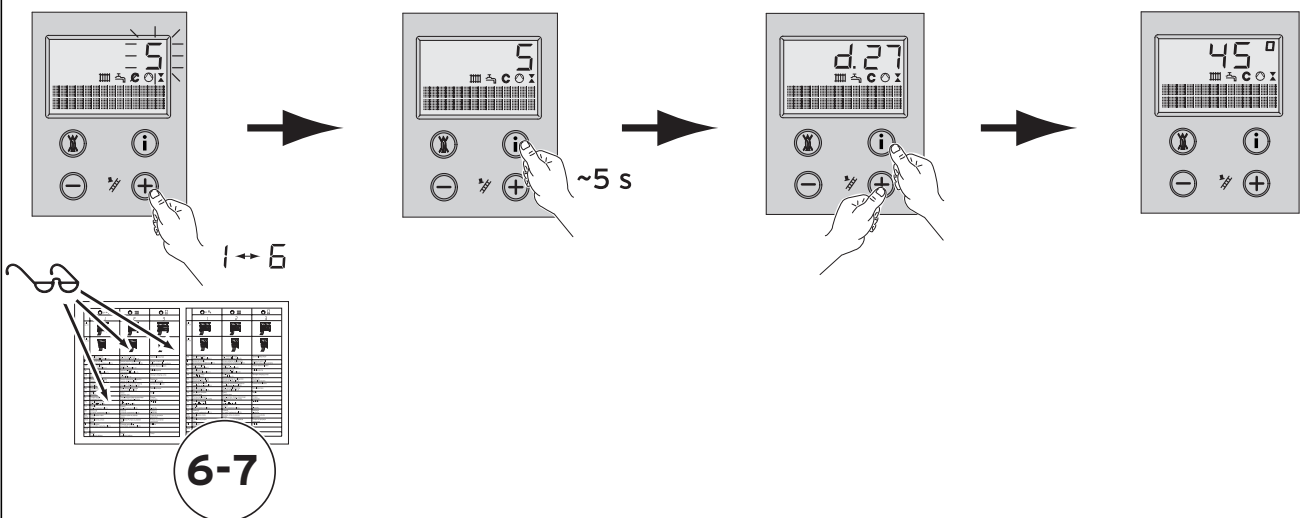
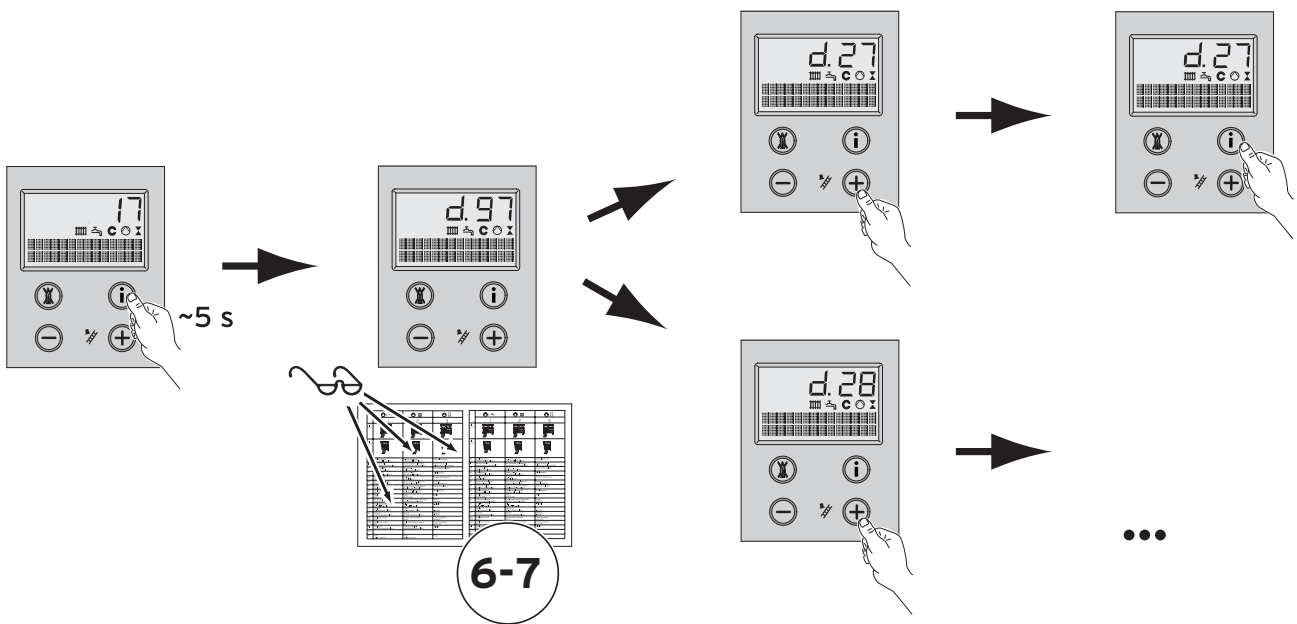
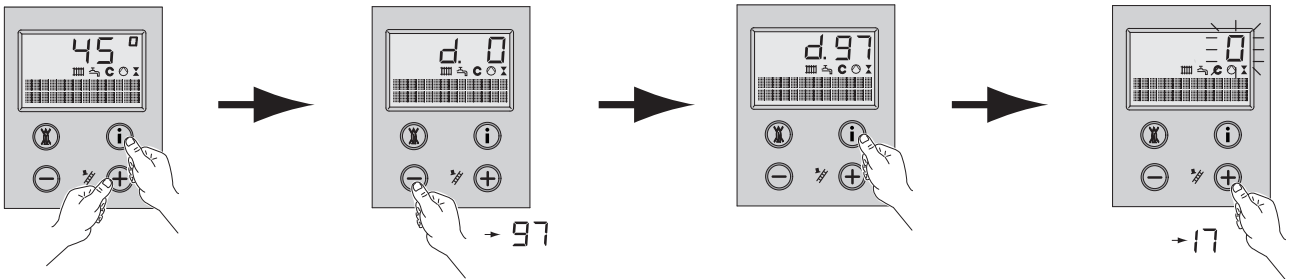

7

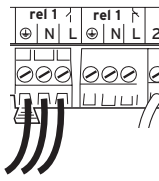
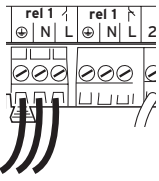
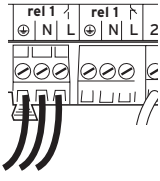
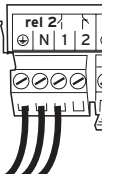
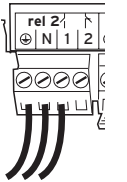
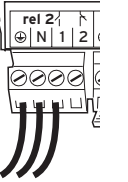

8

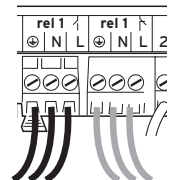
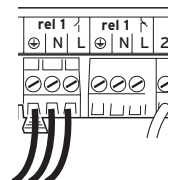
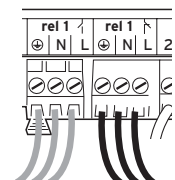
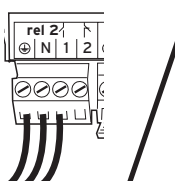
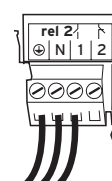
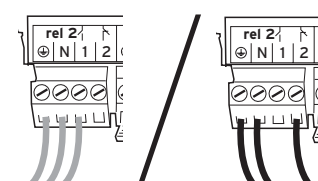

			
	1	2	3
rel.1 (d.27)			
rel.2 (d.28)			
DE	Zirkulationspumpe (Werkseinstellung Relais 1)	ext. Heizungs-Pumpe (Werkseinstellung Relais 2)	Speicherladepumpe
IT	pompa di ricircolo (impostazione di fabbrica relè 1)	pompa esterna riscaldamento (impostazione di fabbrica relè 2)	pompa di carico del bollitore acqua calda sanitaria
FR	pompe circulation (réglage usine relais 1)	pompe ext. (réglage usine relais 2)	pompe d'accumulation
NL	circulatiepomp (fabrieksinstelling relais 1)	externe cv-pomp (fabrieksinstelling relais 2)	boilerlaadpomp
GB	Circulation pump (default relay 1)	Ext. Pump (default relay 2)	Storage charging pump
ES	Bomba de recirculación (ajuste de fábrica relé 1)	Bomba externa de calefacción (ajuste de fábrica relé 2)	Bomba de sobrealimentación
PT	bomba de circulação (regulação de fábrica relé 1)	bomba de aquecimento externa (regulação de fábrica relé 2)	bomba acumuladora
DK	Cirkulationspumpe (fabriksindstilling relæ 1)	Ekst. varmeanlægspumpe (fabriksindstilling relæ 2)	Beholderpumpe
TR	Sirkülasyon pompası (Fabrika ayarı Röle 1)	Harici ısıtma pompası (Fabrika ayarı Röle 2)	Boylor ısıtma pompası
PL	Pompa cyrkulacyjna (nastawa fabryczna - przekaźnik 1)	Zewn. pompa obiegu grzewczego (nastawa fabryczna - przekaźnik 2)	Pompa ładowania zasobnika
HU	Cirkulációs szivattyú (gyári beállítás 1. relé)	Kül.. fűtővíz-szivattyú (gyári beállítás 2. relé)	Tárolótöltő szivattyú
CZ	Cirkulační čerpadlo (tovární nastavení relé 1)	Externí čerpadlo topného okruhu (tovární nastavení relé 2)	Čerpadlo k ohřevu zásobníku
SK	Obehové čerpadlo (výrobné nastavenie relé 1)	Externé čerpadlo vykurovacieho okruhu (výrobné nastavenie relé 2)	Nabíjacie čerpadlo zásobníka
HR/ SOE	Cirkulacijska crpka (tvornička namještenost relej 1)	Vanjska crpka za grijanje (tvornička namještenost relej 2)	Crpka za punjenje spremnika
SCG	Cirkulaciona pumpa (fabrički podešen relej 1)	Spoljašnja Pumpa za grejanje (fabrički podešen relej 2)	Pumpa za punjenje rezervoara
SI	Cirkulacijska črpalka (tovarniška nastavev, rele 1)	Zunanja ogrevalna-črpalka (tovarniška nastavev, rele 2)	Polnilna črpalka zbiralnika
GUS	Циркуляционный насос (заводская настройка реле 1)	Внешний отопительный насос (заводская настройка реле 2)	Насос нагрева водонагревателя
RO	Pompă de recirculare (reglaj din fabricație releul 1)	Pompă externă de încălzire (reglaj din fabricație releul 2)	Pompă de încărcarea a boilerului

		 LPG	
	4	5	6
rel.1 (d.27)			
rel.2 (d.28)			
DE	Abgasklappe/ Dunstabzughabe	externes Gasventil	externe Fehlermeldung/ Betriebsanzeige
IT	sportello fumi/ aspiratore domestico	valvola intercettazione gas esterna	Indicatore disfunzioni/ Indicatore d'esercizio
FR	clapet évacuation/ hotte aspirante	vanne gaz externe	message d'erreur externe/ Affichage de l'état de fonctionnement
NL	verbrandingsgasklep/ wasemkap (afzuigkap)	extern gasventiel	externe storingsmelding/ inbedrijfmelding
GB	Flue gas flap/ extractor hood	External gas valve	External error message/ Operation indicator
ES	Panel de evacuación de gases/ campana de extracción de condensación	Válvula de gas externa	Aviso de error externo/ indicador de funcionamiento
PT	tampa dos gases de exaustão/ extractor de fumos	válvula do gás externa	mensagem de erro externa/ indicador de funcionamento
DK	Røggasklap/ emhætte	Ekstern gasventil	Ekstern fejlmelding/ driftskontrolampe
TR	Baca gazı kapağı/ Aspiratör	Harici gaz vanası	Harici arıza mesajı/ işletme göstergesi
PL	Przepustnica spalin/ wyciąg oparów	Zewnętrzny zawór gazu	Zewnętrzny komunikat awaryjny/ dioda kontrolna
HU	Füstgázcsappantyú/ páraelszívó-burkolat	Külső gázszelep	Külső hibaüzenet/ üzemkijelző
CZ	Spalinová klapka/ kryt odvodu par	Externí plynový ventil	Externí chybové hlášení/ indikátor provozu
SK	Spalinová klapka/ kryt odsávača pár	Externý plynový ventil	Externé chybové hlásenie/ indikátor prevádzky
HR/ SOE	Zaklopka za ispušni plin/ poklopac za odvod plinova	Vanjski plinski ventil	Vanjska dojava greške/ pokazivač načina rada
SCG	Klapna dimnih gasova/ poklopac za odvod gasova	Spoljašnji gasni ventil	Spoljašnja prijava greške/ pokazivač načina rada
SI	Loputa izpušnih plinov/ auba za odvajanje pare	Zunanji plinski ventil	Zunanje javljanje napake/ indikator obratovanja
GUS	Заслонка газохода/ Вытяжной коппак	Внешний газовый клапан	Внешний индикатор сообщения об ошибке/рабочий индикатор
RO	Clapetă pentru gaze arse/ hotă	Ventil extern de gaz	Mesaj extern de eroare/ indicator funcțional

Vaillant GmbH

Berghauser Str. 40 ■ 42859 Remscheid ■ Telefon 0 21 91/18-0
Telefax 0 21 91/18-28 10 ■ www.vaillant.de ■ info@vaillant.de

0020008433_01 INT 02 2006