

# VIVALA 3D3DR

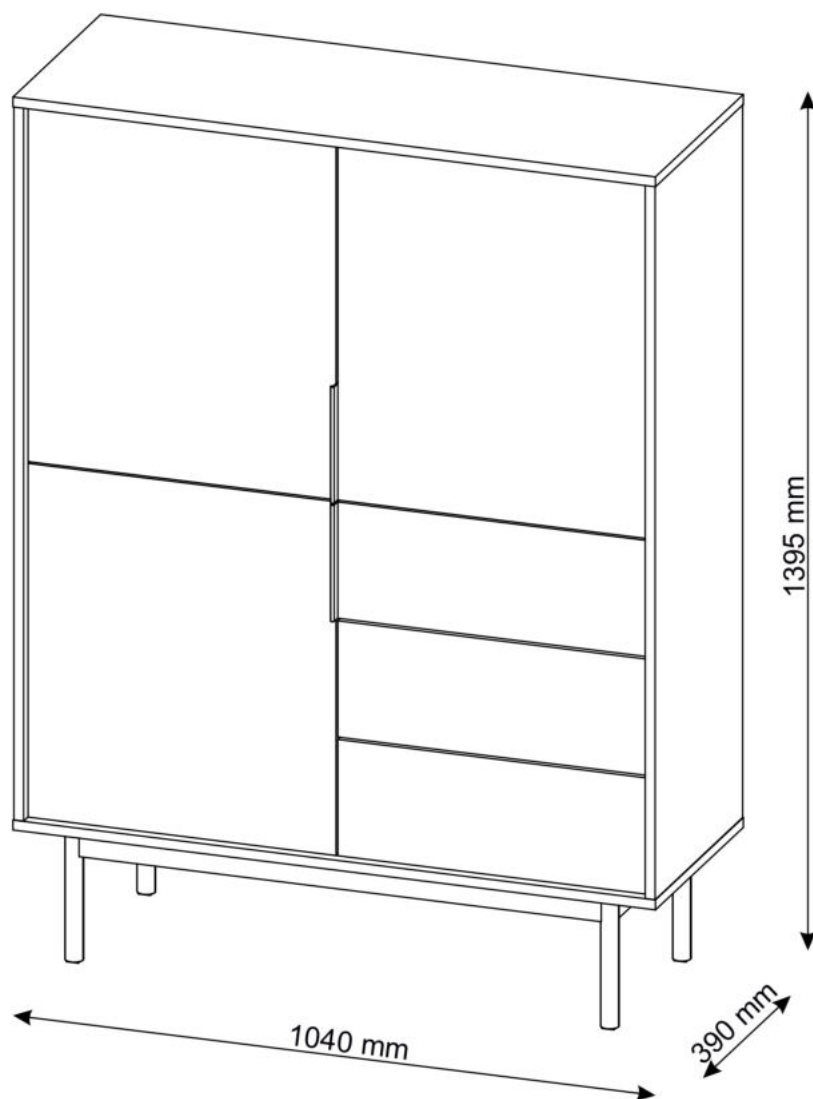

**CZ** Povrch nábytku čistíte pouze přípravky určenými k ošetřování nábytku.

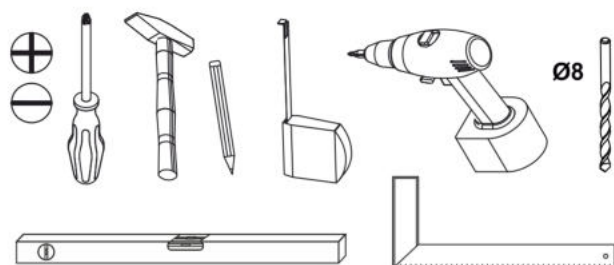

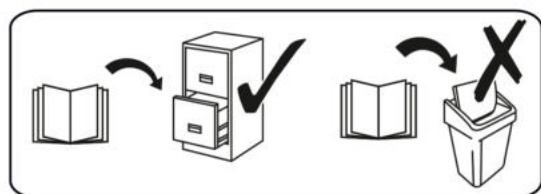







**SK** Povrch nábytku čistíte iba prostriedkami určenými na ošetrovanie nábytku.











**RO** Suprafata ei trebuie să fie curătată numai cu substanțe destinate pentru curățarea mobilei.

**HU** A bútor felületét csak bútorápoló szerekkel szabad tisztítani.

**HR** Površinu namještaja treba čistiti samo sredstvima za njegu namještaja

**SI** Površino pohištva čistite samo s sredstvi za nego pohištva.

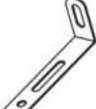
<b>A0</b>	<b>A1</b>	<b>B1</b>	<b>B4</b>	<b>C2</b>	<b>C4</b>	<b>C6</b>	<b>C7</b>	<b>D0</b>	<b>D4</b>	<b>D5</b>
										
Ø8x30	Ø8x50	Ø7x50				84 mm	16 mm	3x15	3.5x16	3.5x16
<b>x28</b>	<b>x2</b>	<b>x30</b>	<b>x30</b>	<b>x22</b>	<b>x26</b>	<b>x2</b>	<b>x26</b>	<b>x34</b>	<b>x13</b>	<b>x28</b>

<b>D21</b>	<b>E0</b>	<b>J5</b>	<b>K</b>	<b>L21</b>	<b>M1</b>	<b>M3</b>	<b>N12</b>	<b>P0</b>	<b>Q0</b>	<b>Q4</b>
										
5x13	8x50		4mm				L-300			
<b>x24</b>	<b>x2</b>	<b>x6</b>	<b>x1</b>	<b>x2</b>	<b>x25</b>	<b>x9</b>	<b>x3</b>	<b>x2</b>	<b>x12</b>	<b>x3</b>

<b>U2</b>

<b>x4</b>

3x15



**D0**

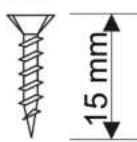

3.5x16



**D5**

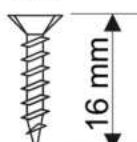

5x13



**D21**

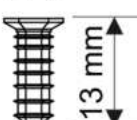

3.5x16



**D4**

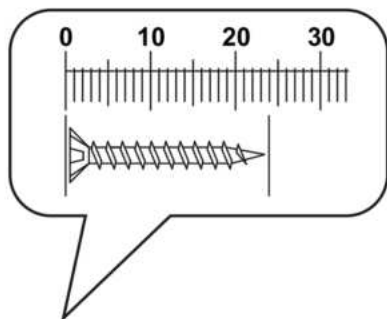
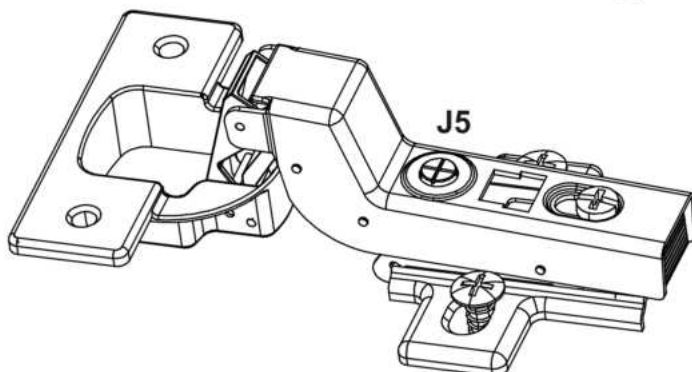
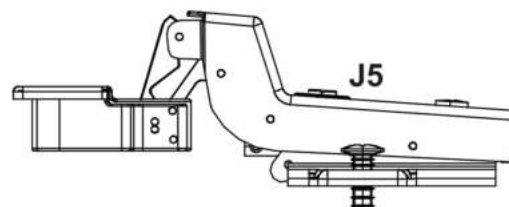
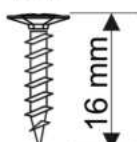

1	1039	390	16	x1	2/2
2	1039	390	16	x1	2/2
3	1153	389	16	x1	2/2
4	1153	338	16	x1	2/2
5	578	348	16	x1	2/2
6	494	335	16	x3	1/2
7	494,5	335	16	x2	1/2
8	572	498	16	x2	1/2
9	572	498	16	x1	1/2
10	498	188	16	x3	1/2
11	300	120	16	x3	2/2
12	436,5	100	16	x3	1/2
13	300	120	16	x3	2/2
14	445	305	3	x3	1/2
15	580	507	3	x2	1/2
16	580	507	3	x2	1/2
17	210	28	28	x4	2/2
18	296	40	18	x2	2/2
19	1288	40	18	x2	2/2
					1/2

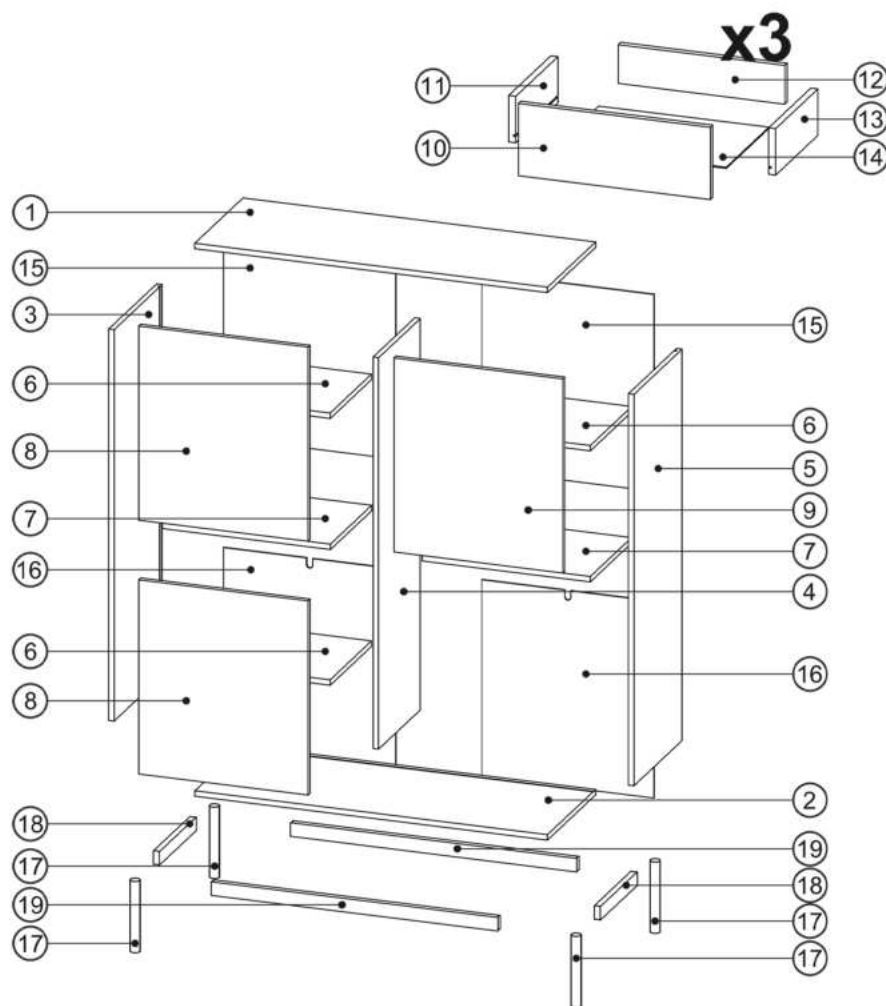

### CZ: Připevnění ke stěně

Prosím, nesbírejte nábytek, pokud jsou jeho prvky poškozené. Před montáží je nutné pečlivě prohlédnout jednotlivé prvky nábytku. V případě jejich poškození je třeba je nahlásit spolu s fotodokumentací pro posouzení reklamace a přijetí vhodných opatření.

### SK: Pripevnenie na stenu

Prosím, nezberajte nábytok, ak sú jeho prvky poškodené. Pred montážou je potrebné dôkladne prezrieť jednotlivé prvky nábytku. V prípade ich poškodenia je potrebné nahlásiť ich spolu s fotodokumentáciou pre posúdenie reklamácie a prijatie vhodných opatrení.

### RO: Ataşaţi la perete

Vă rugăm să nu colectaţi mobilier dacă elementele acesteia sunt deteriorate. Înainte de asamblare, este necesar să inspectaţi cu atenţie elementele individuale ale mobilierului. În caz de deteriorare a acestora, trebuie raportat împreună cu documentaţia foto pentru a lua în considerare reclamaţia şi a lua măsurile corespunzătoare

### HU: A falhoz rögzítés

Kérjük, ne gyűjtse össze a bútort, ha azok elemei sérültek. Összeszerelés előtt alaposan meg kell vizsgálni a bútor egyes elemeit. Ha megsérülnek, fényképes dokumentációval együtt be kell jelenteni a panasz mérlegelésére és a megfelelő intézkedések megtételére.

### HR: Montaža na zid

Molimo nemojte skupljati namještaj ako su njegovi dijelovi oštećeni. Prije montaže potrebno je pažljivo pregledati pojedine elemente namještaja. U slučaju oštećenja iste potrebno je prijaviti uz fotodokumentaciju kako bi se reklamacija razmotrila i poduzele odgovarajuće mjere.

### SI: Pritrdite na steno

Ne zbirajte pohištva, če so njegovi elementi poškodovani. Pred montažo je potrebno natančno pregledati posamezne elemente pohištva. V primeru poškodb le-teh je potrebno prijaviti skupaj s fotodokumentacijo, da se reklamacija obravnava in ustrezno ukrepa

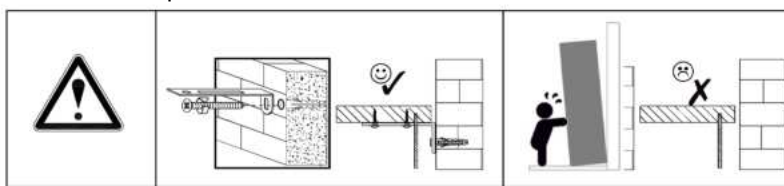



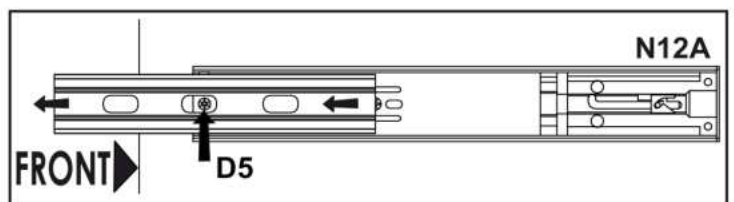
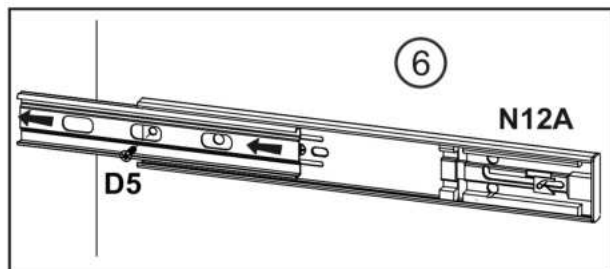
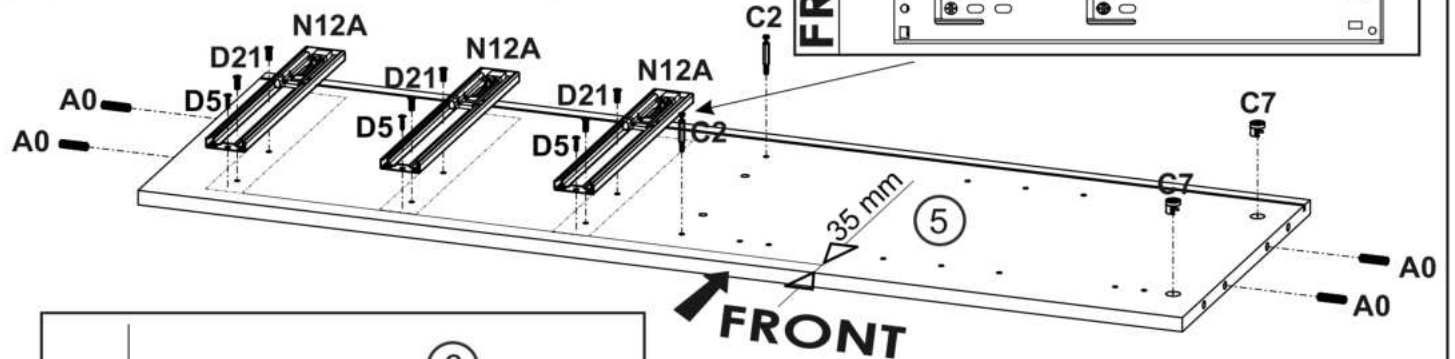
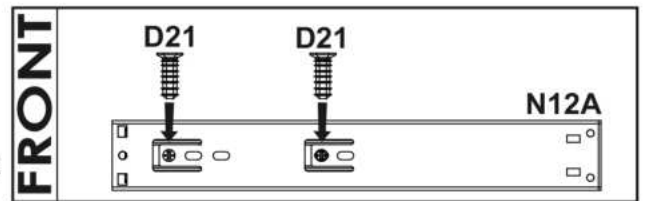
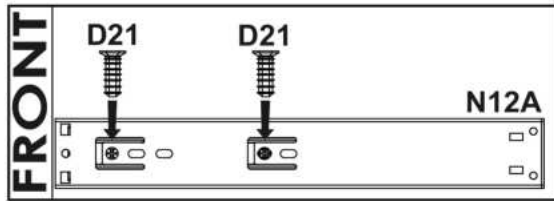
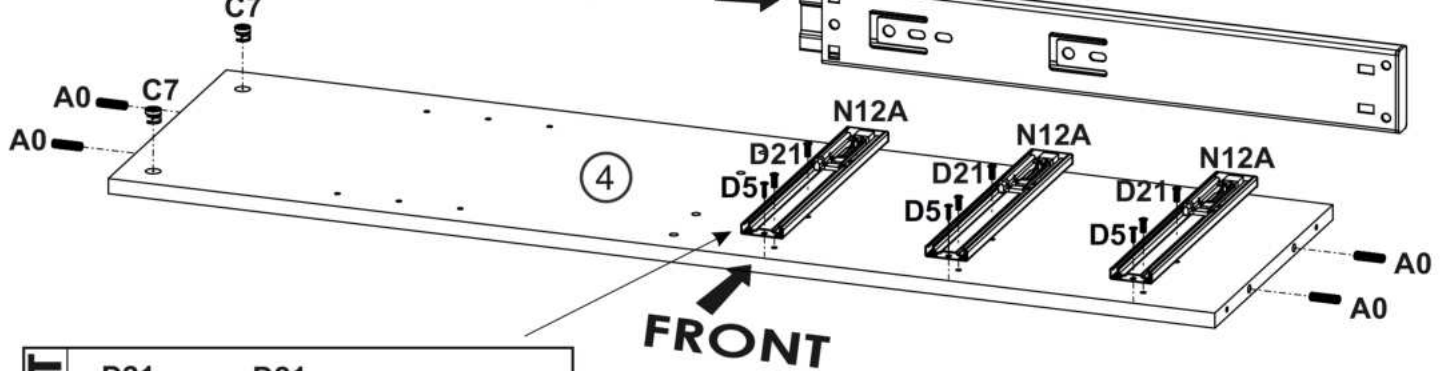
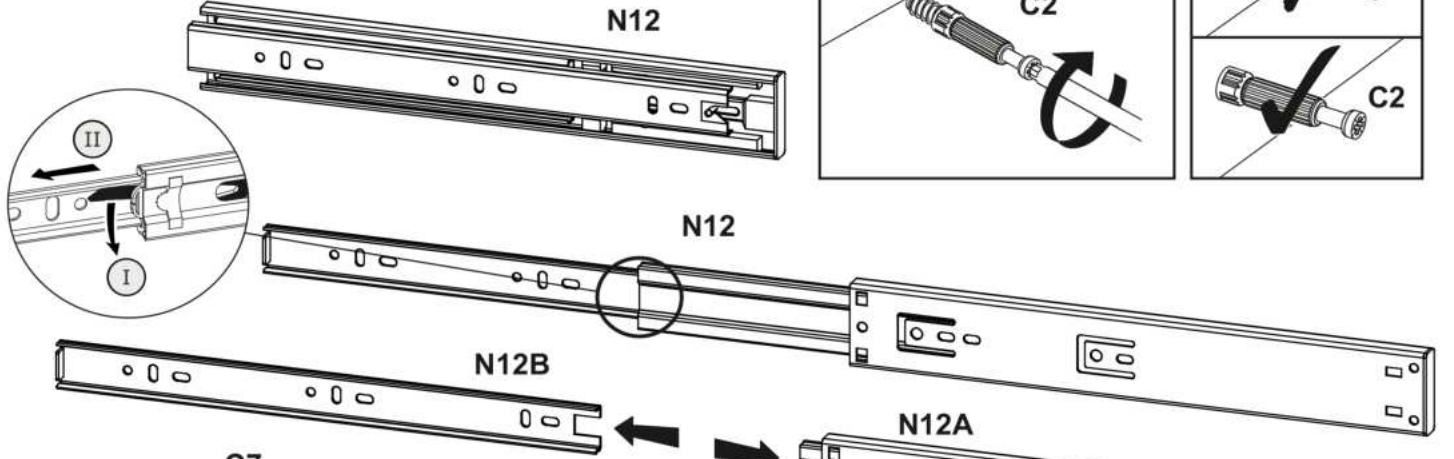
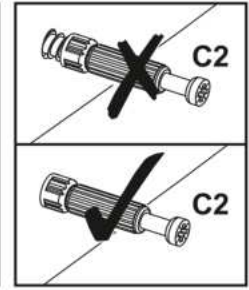
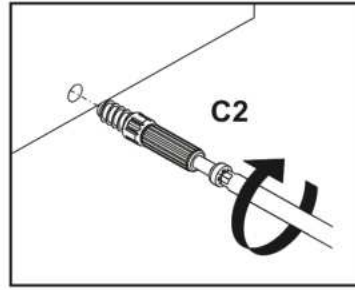
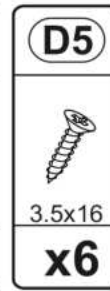
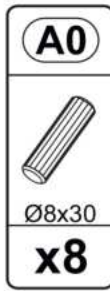
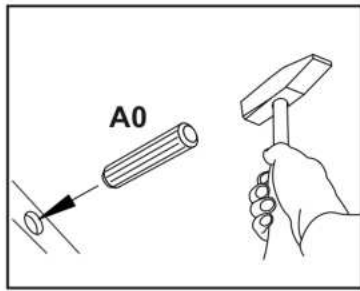
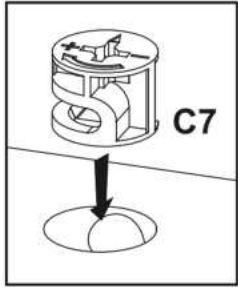

# 1



# 2

# I

  
**x2**

<b>A0</b>  Ø8x30 <b>x12</b>	<b>A1</b>  Ø8x50 <b>x2</b>	<b>C6</b>  84 mm <b>x2</b>	<b>C7</b>  16 mm <b>x20</b>
---	--	--	---

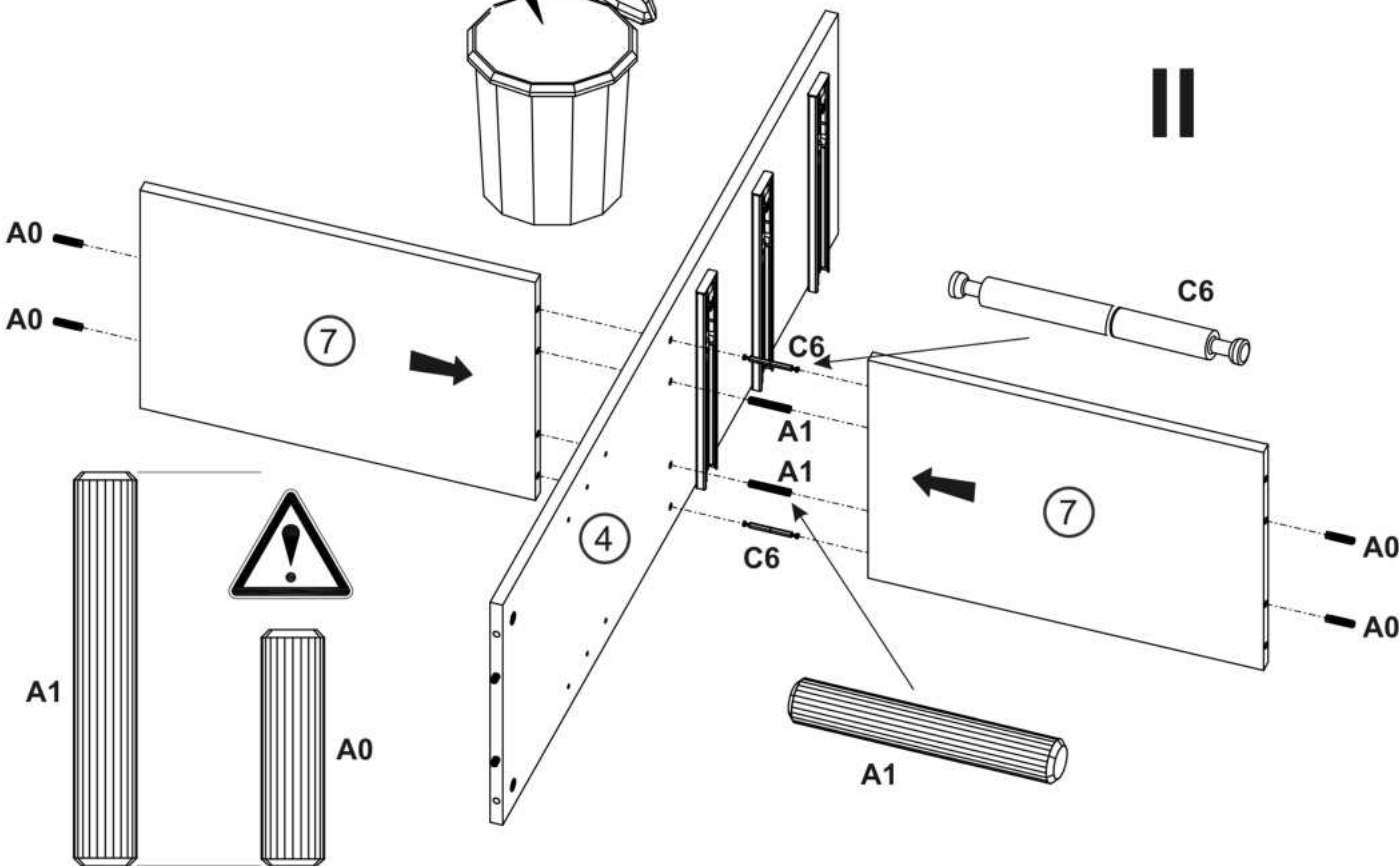
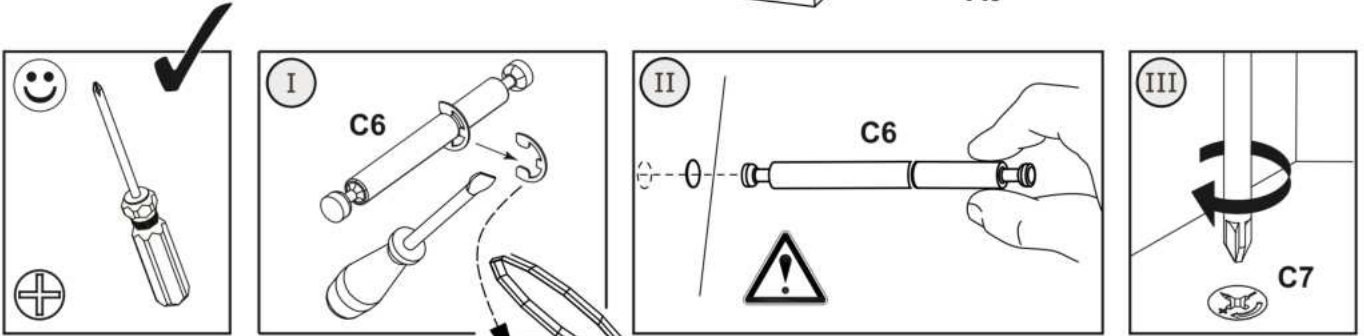
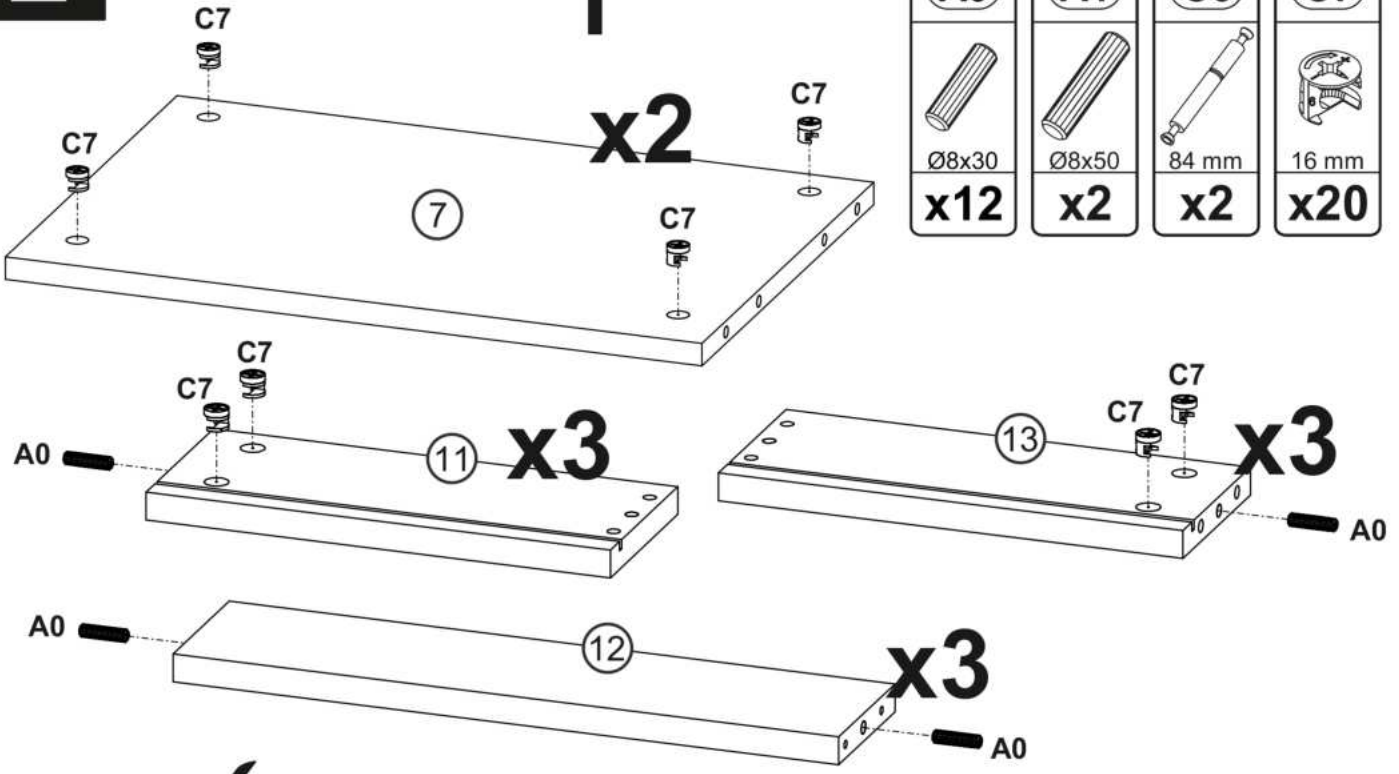

**3**



<b>A0</b>	<b>C2</b>	<b>C7</b>
Ø8x30		16 mm
<b>x4</b>	<b>x2</b>	<b>x2</b>

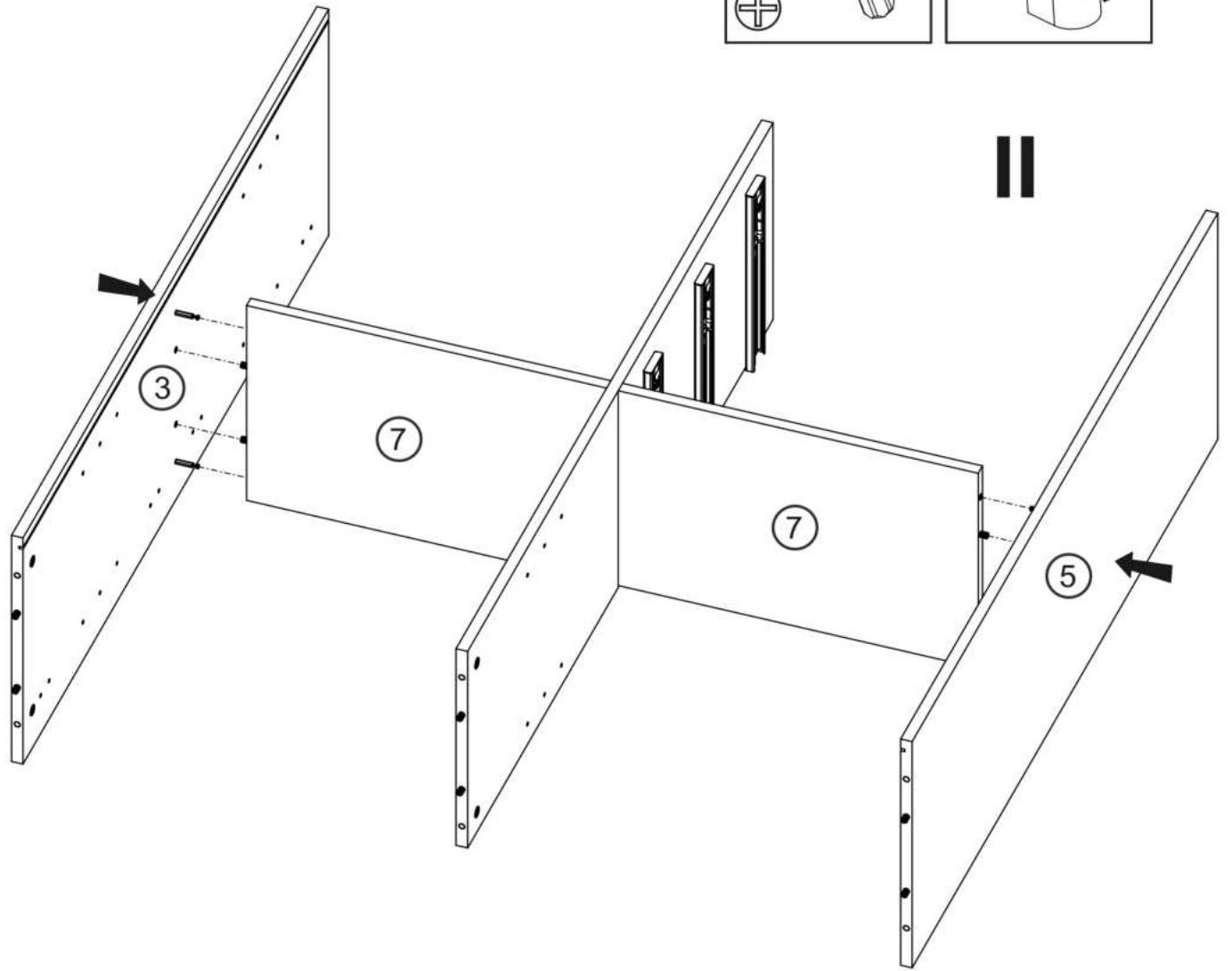
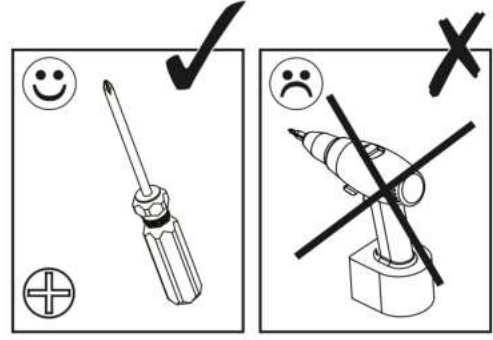
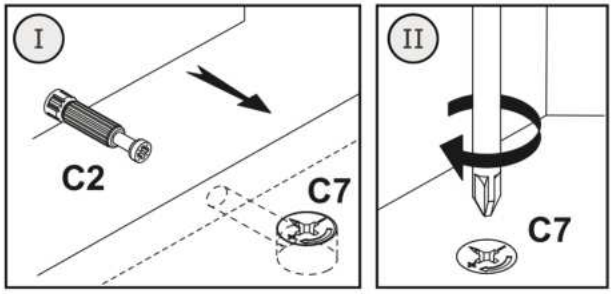
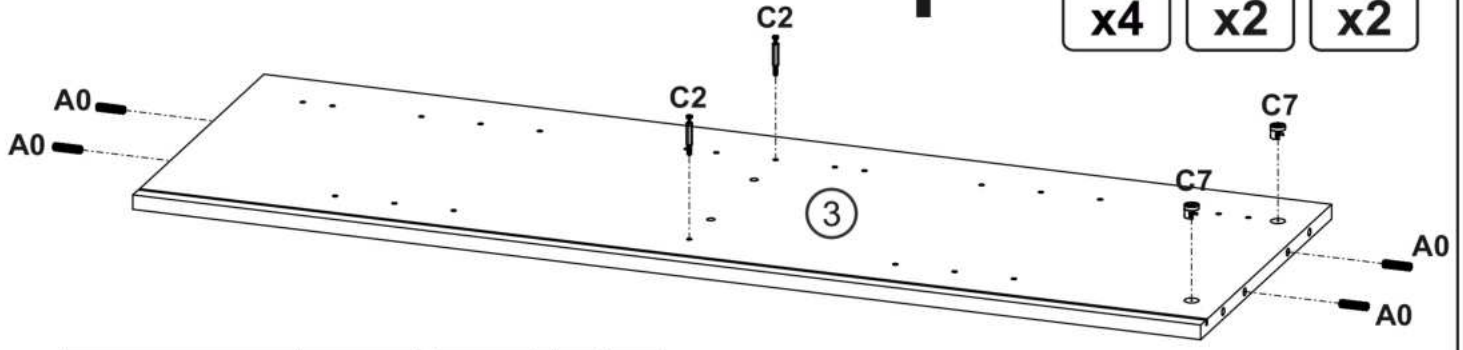

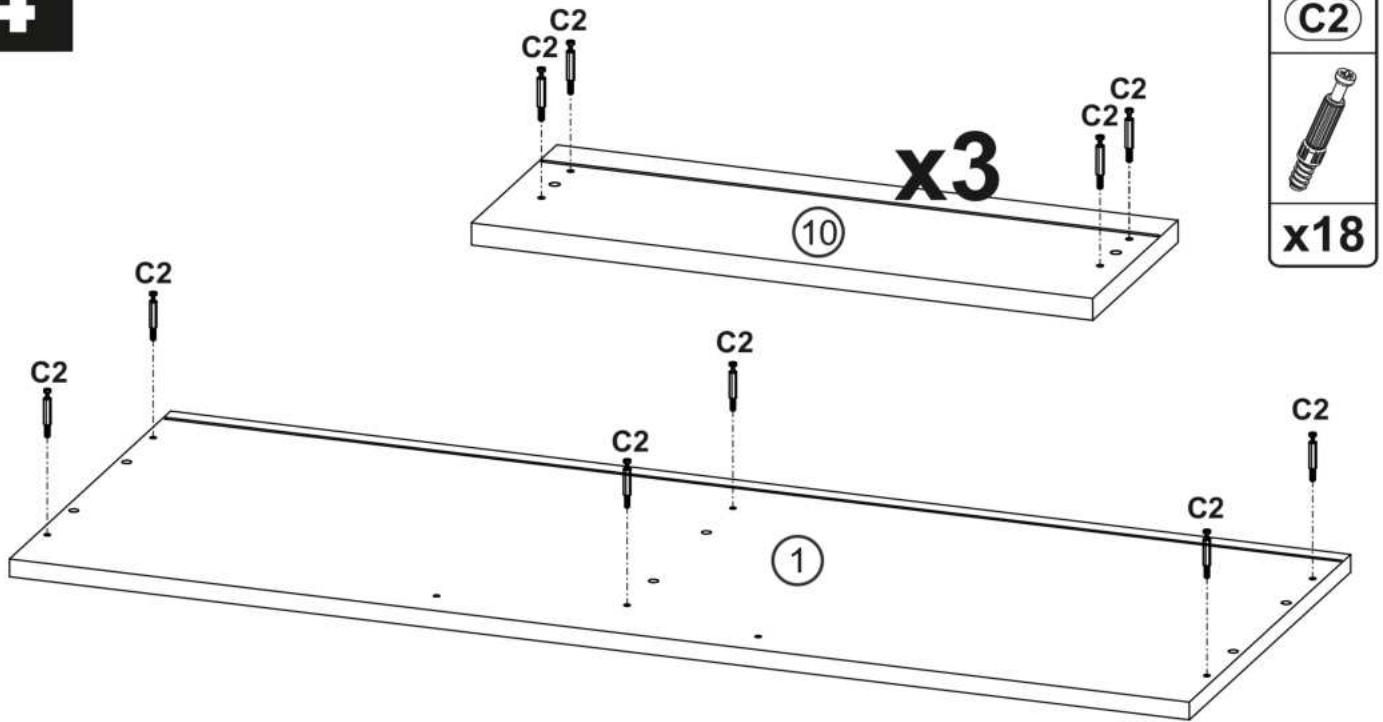
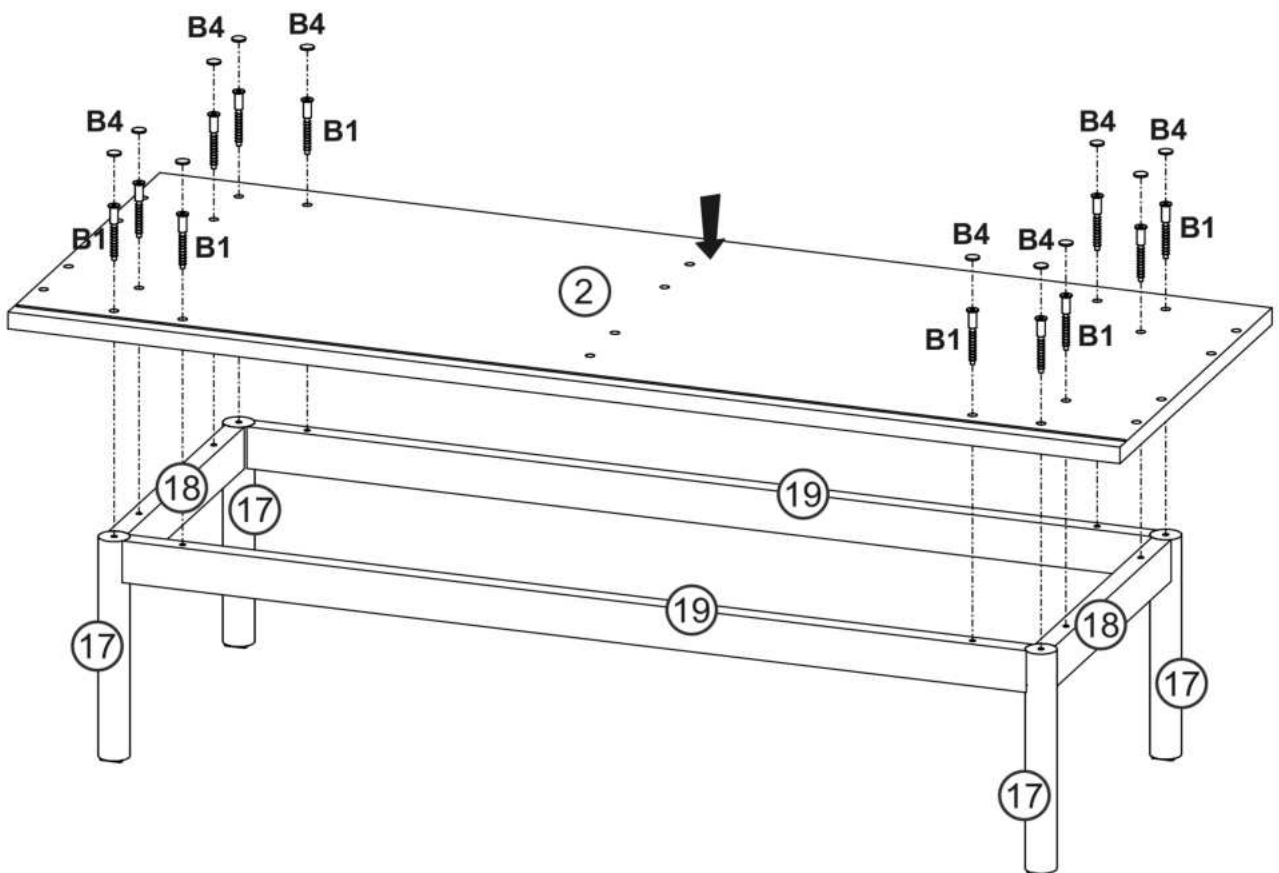
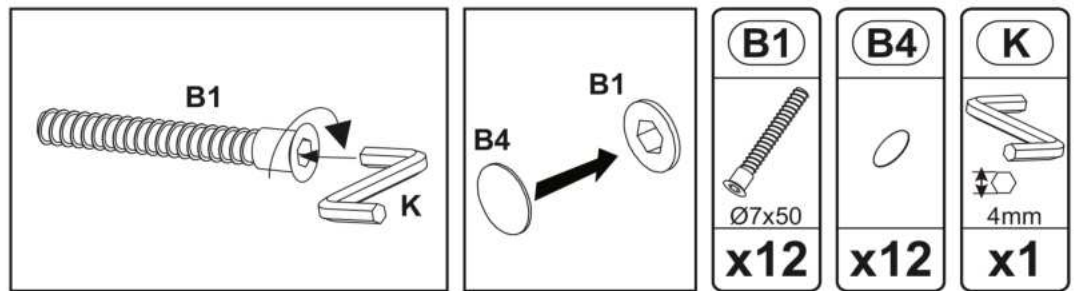
**4****5**

6

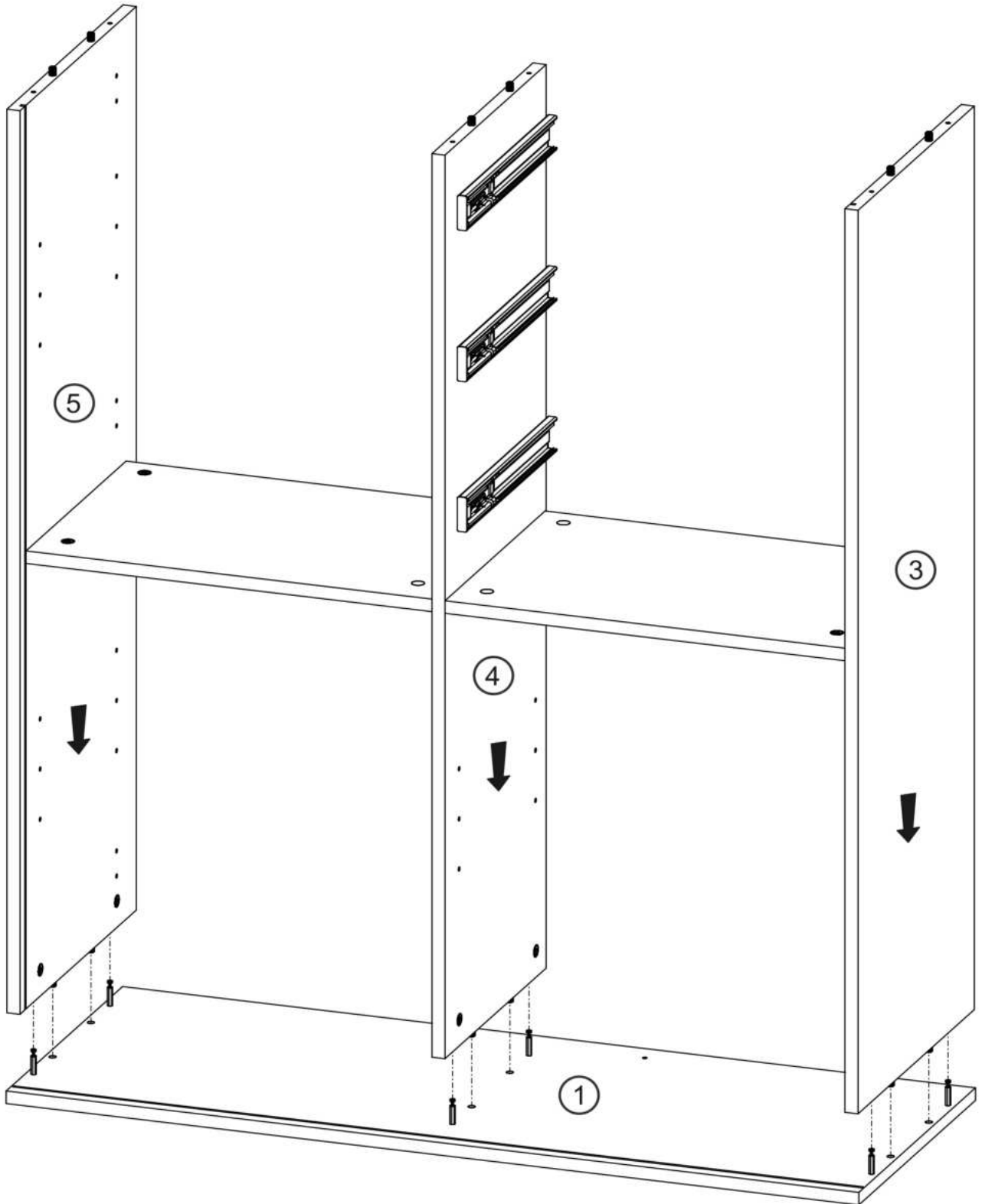
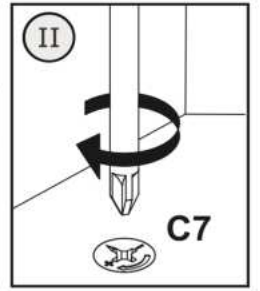
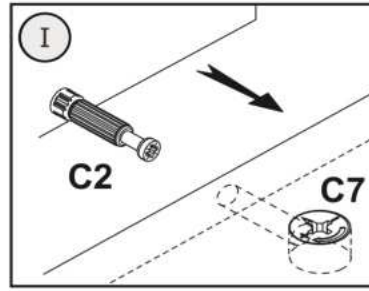



# 7

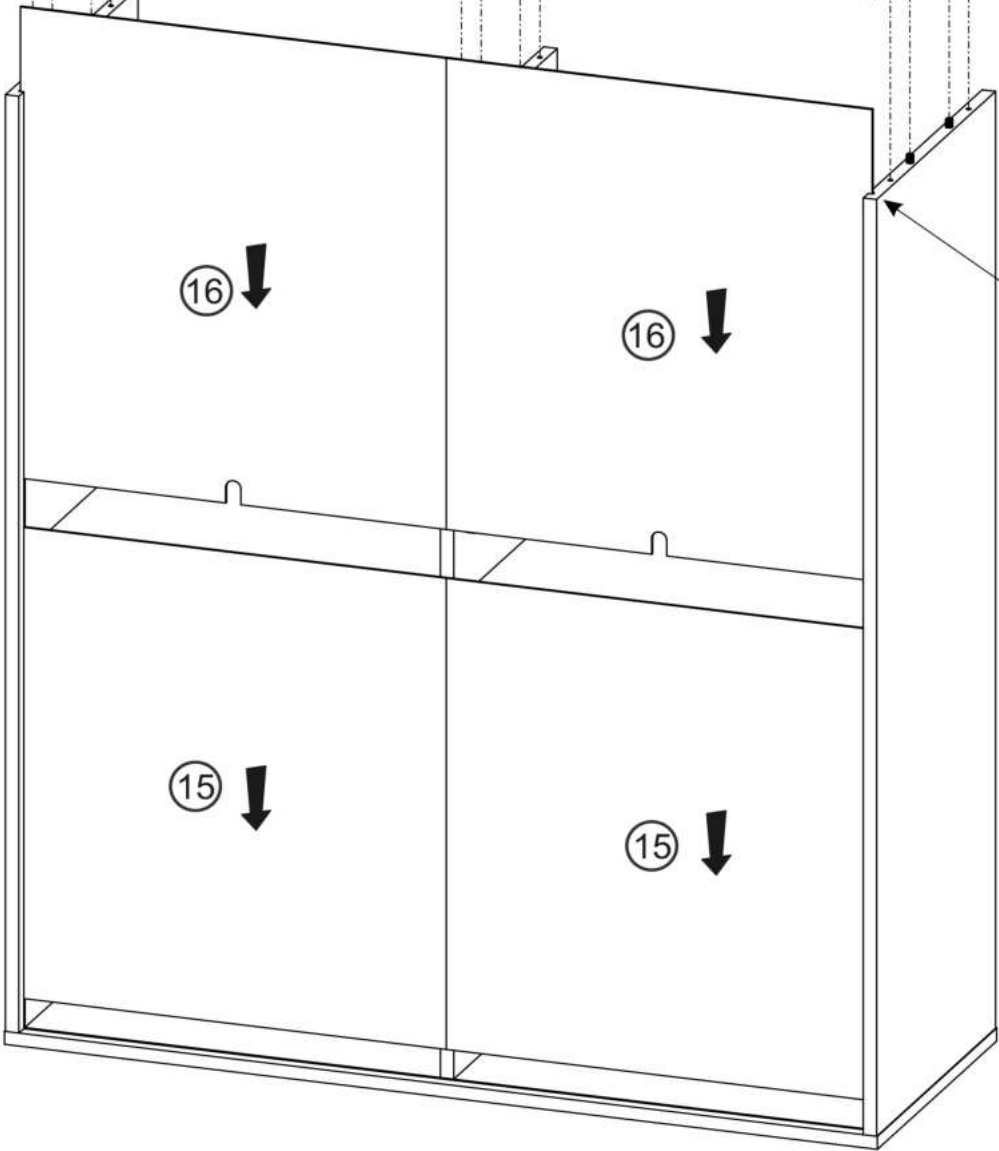
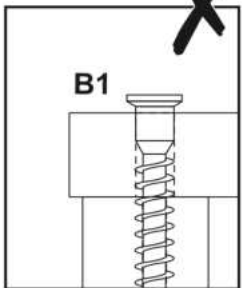
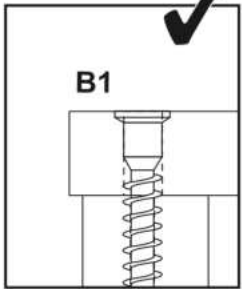
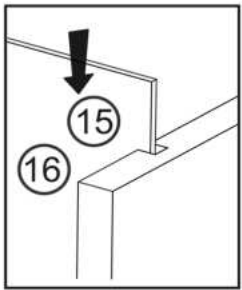
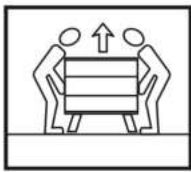
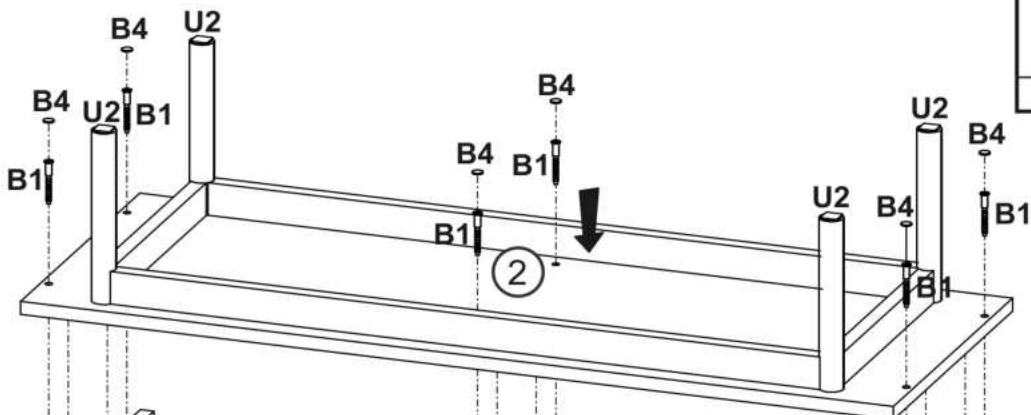
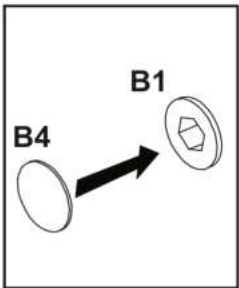
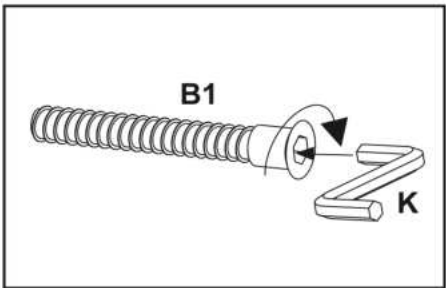



<b>D0</b>	<b>M1</b>	<b>M3</b>
3x15		
<b>x25</b>	<b>x16</b>	<b>x9</b>

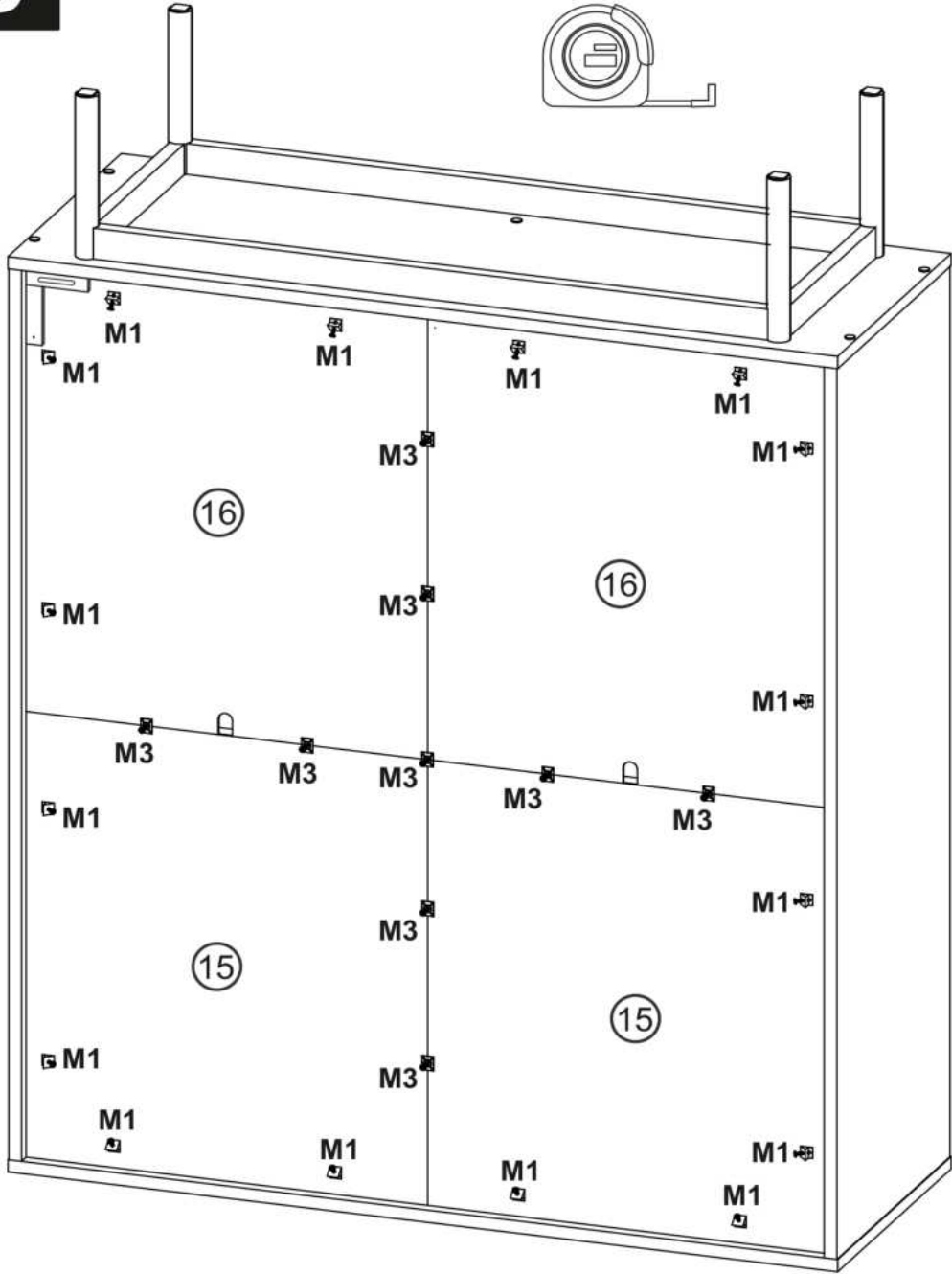

3x15



**D0**



15 mm

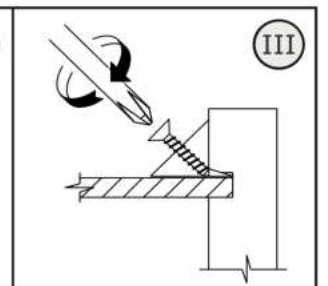
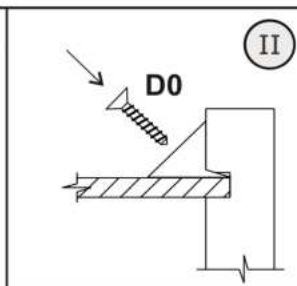
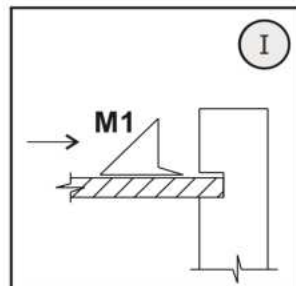
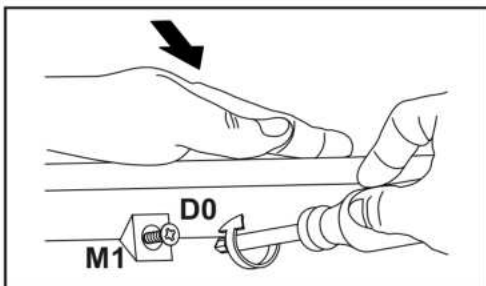
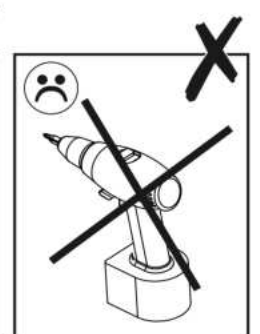
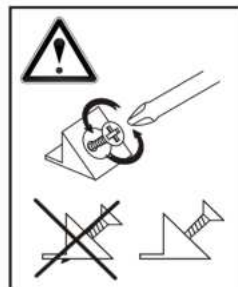
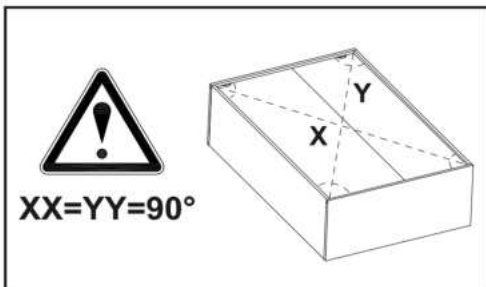
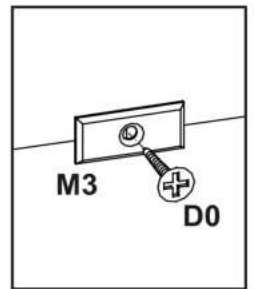
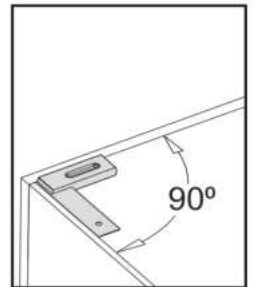

# 9

3.5x16



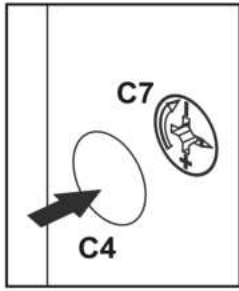
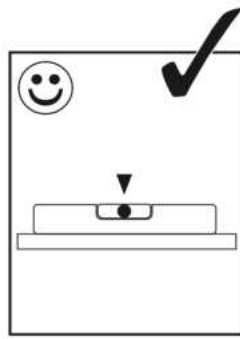

D5

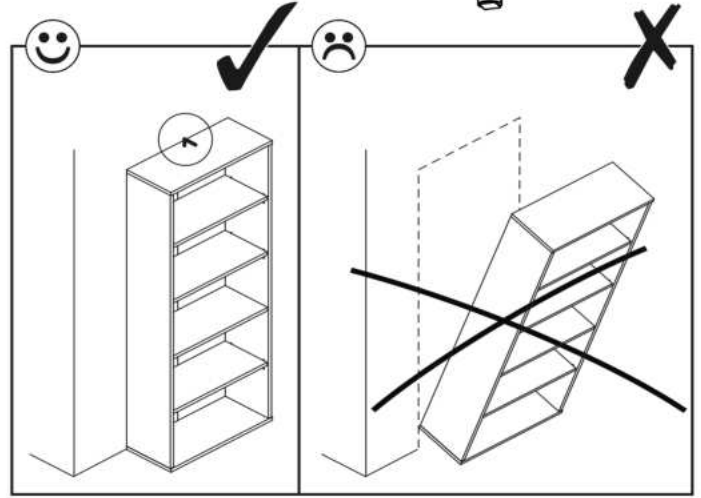
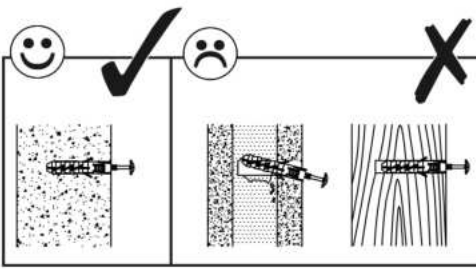
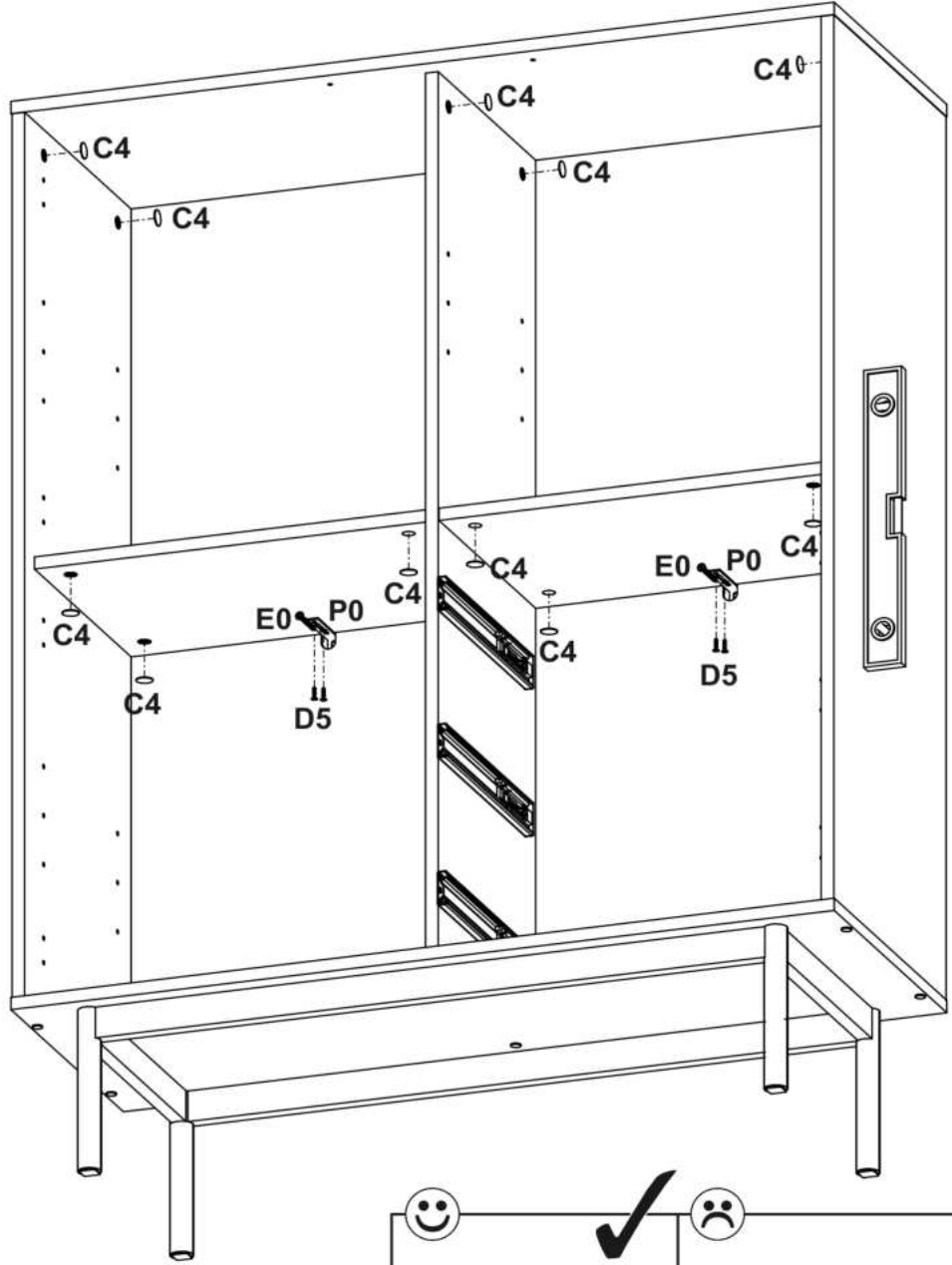
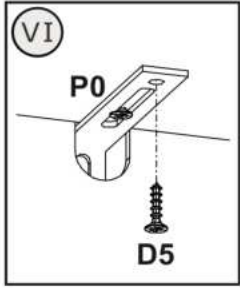
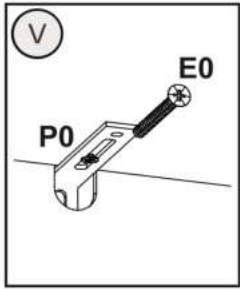
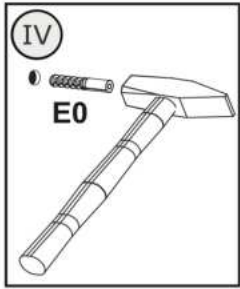
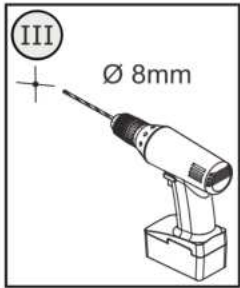
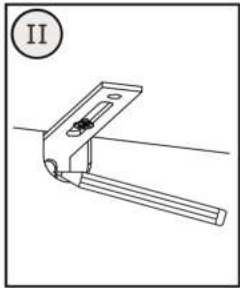
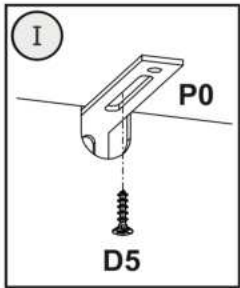

<b>C4</b>	<b>D5</b>	<b>E0</b>	<b>P0</b>
<b>x14</b>	3.5x16 <b>x4</b>	8x50 <b>x2</b>	<b>x2</b>



# 10

<b>B1</b>  Ø7x50 <b>x12</b>	<b>B4</b>  <b>x12</b>	<b>K</b>  4mm <b>x1</b>
---	--	---

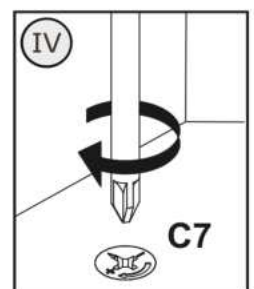
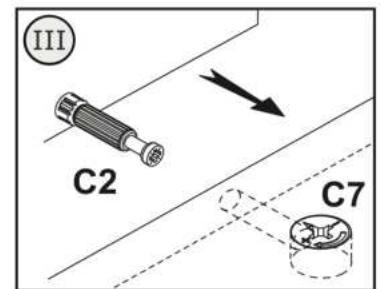
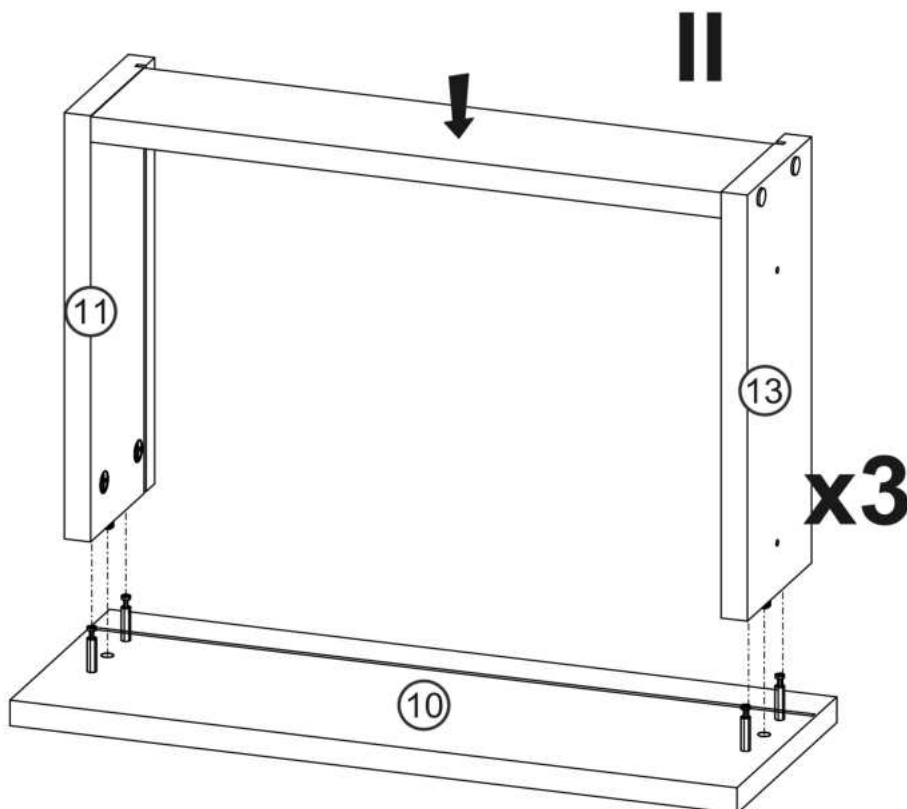
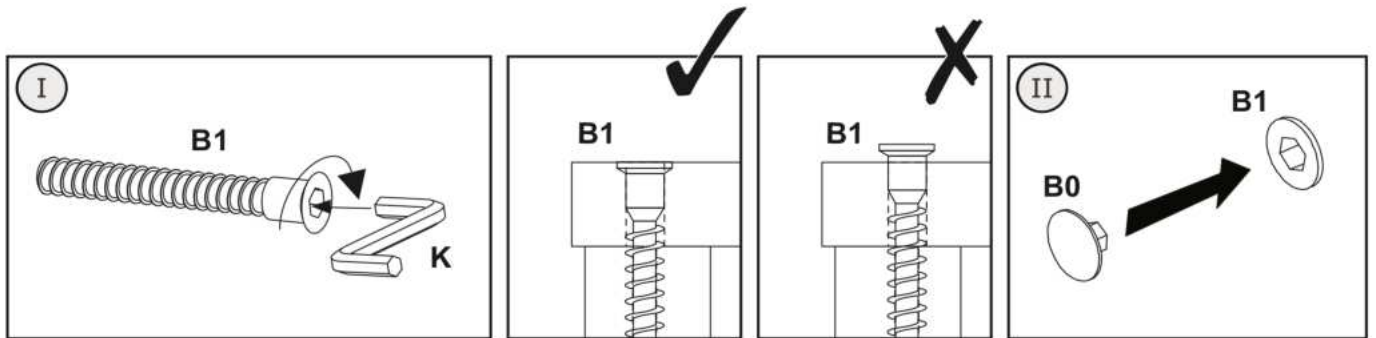
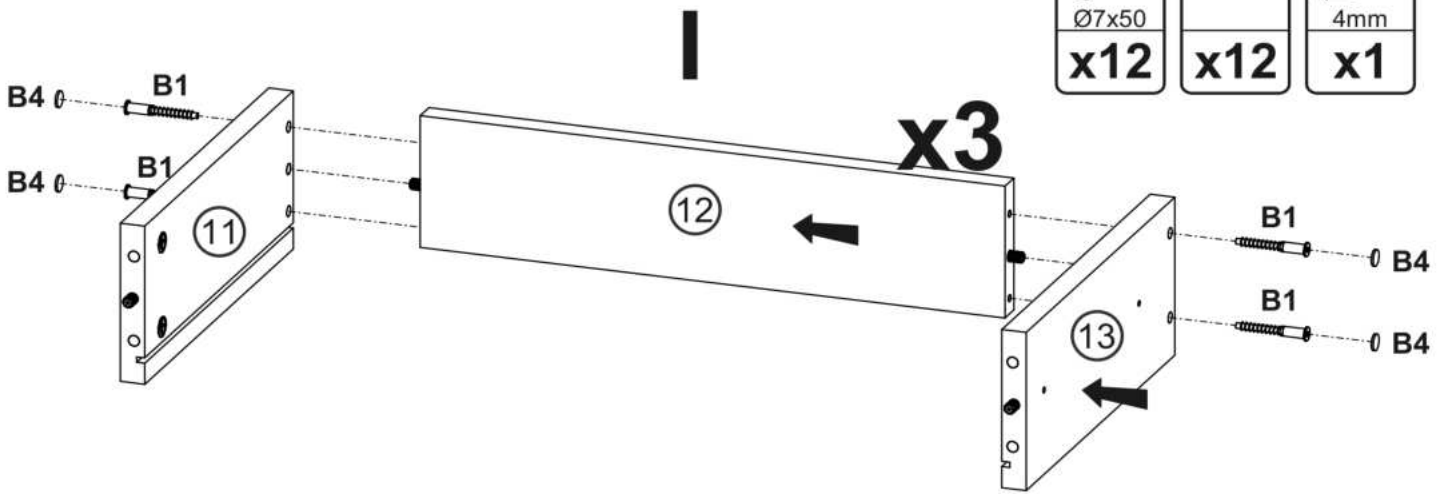

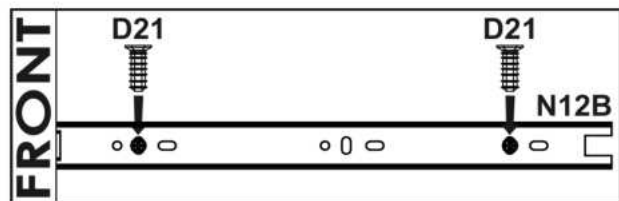

<b>C4</b>	<b>D0</b>	<b>D4</b>	<b>D21</b>	<b>M1</b>	<b>N12</b>
<b>x12</b>	3x15 <b>x9</b>	3.5x16 <b>x9</b>	5x13 <b>x12</b>	<b>x9</b>	L-300 <b>x3</b>

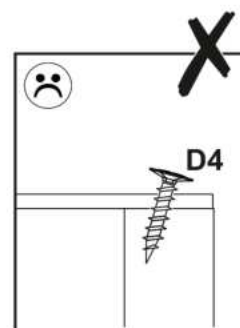
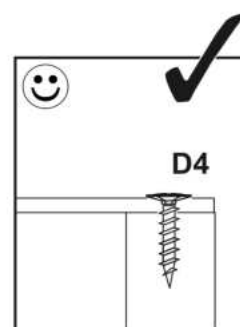
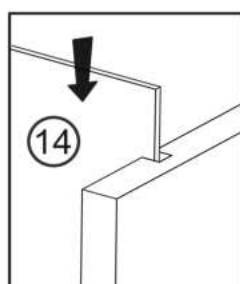
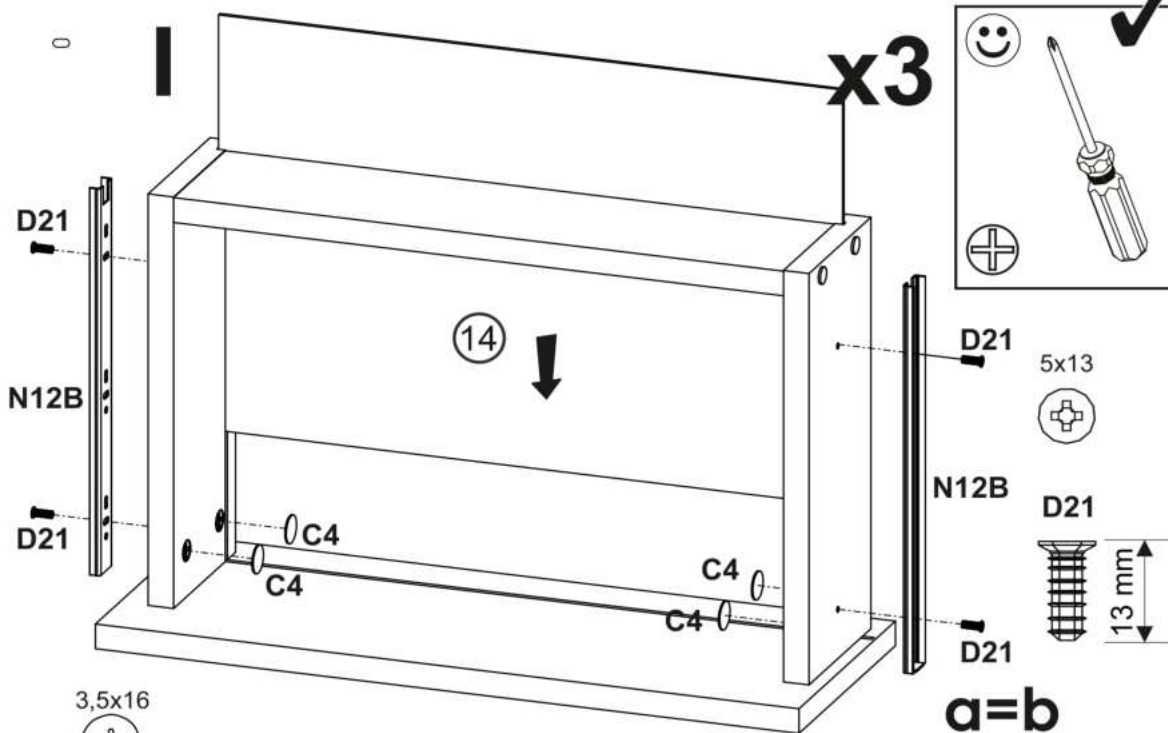

3,5x16

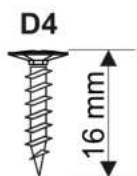

II

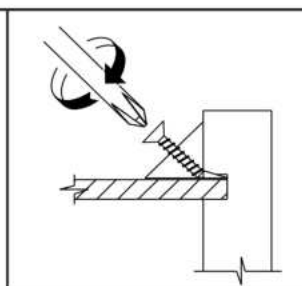
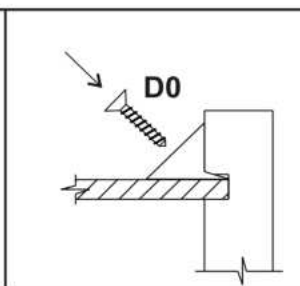
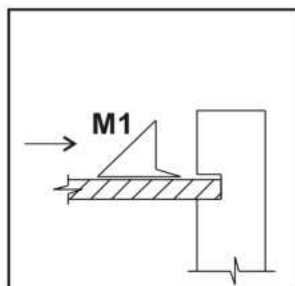
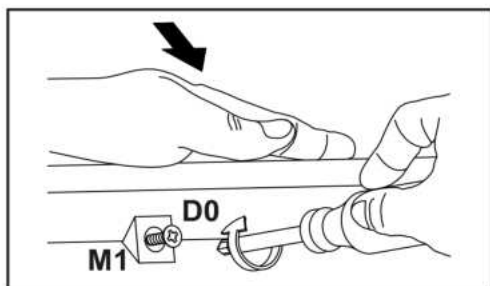
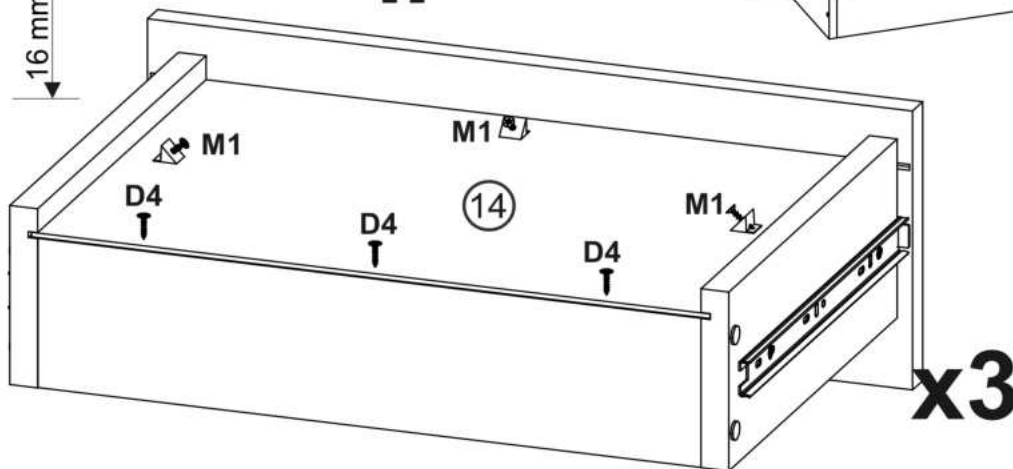

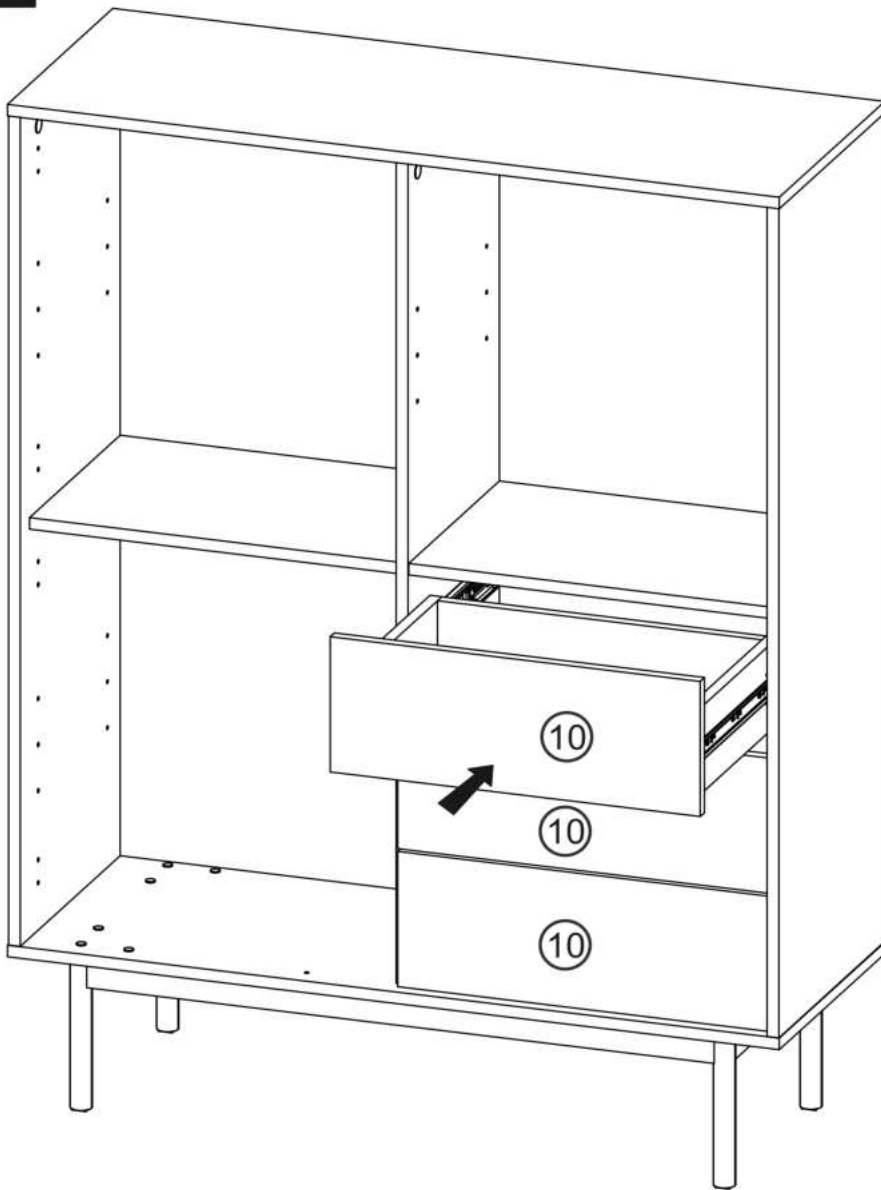

**D5**

3.5x16

**x6**

3.5x16



**D5**



16 mm

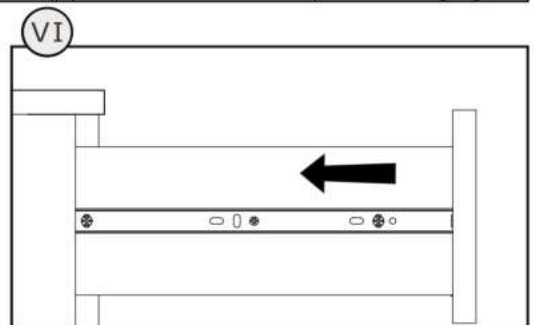
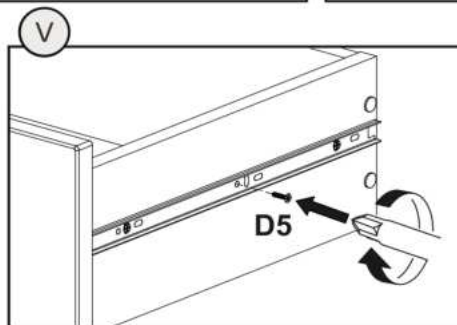
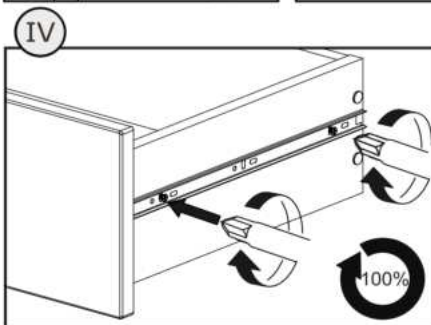
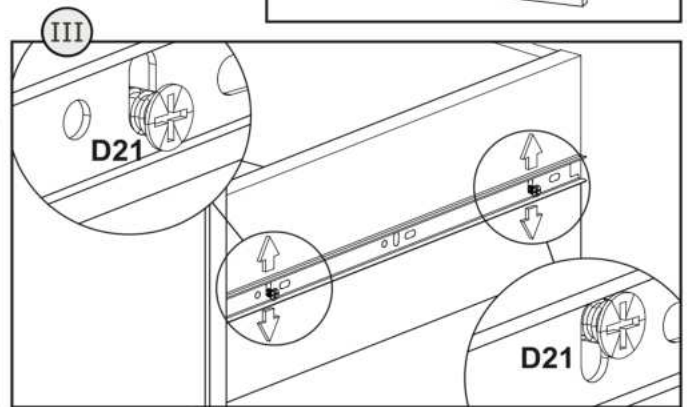
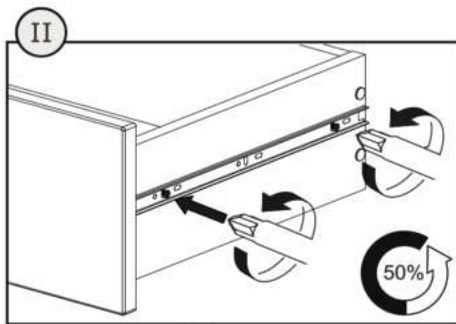
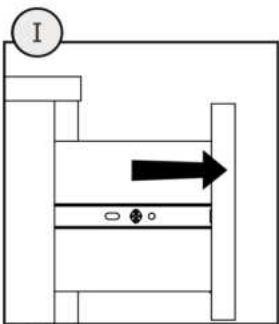
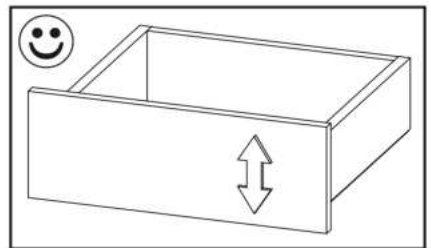
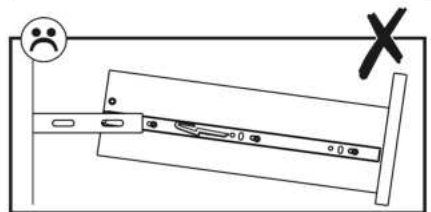
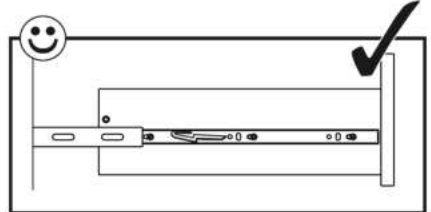
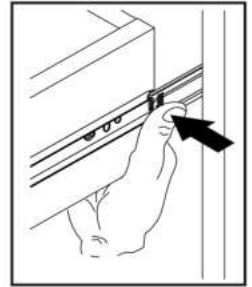

# 13

3.5x16



D5

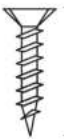

16 mm

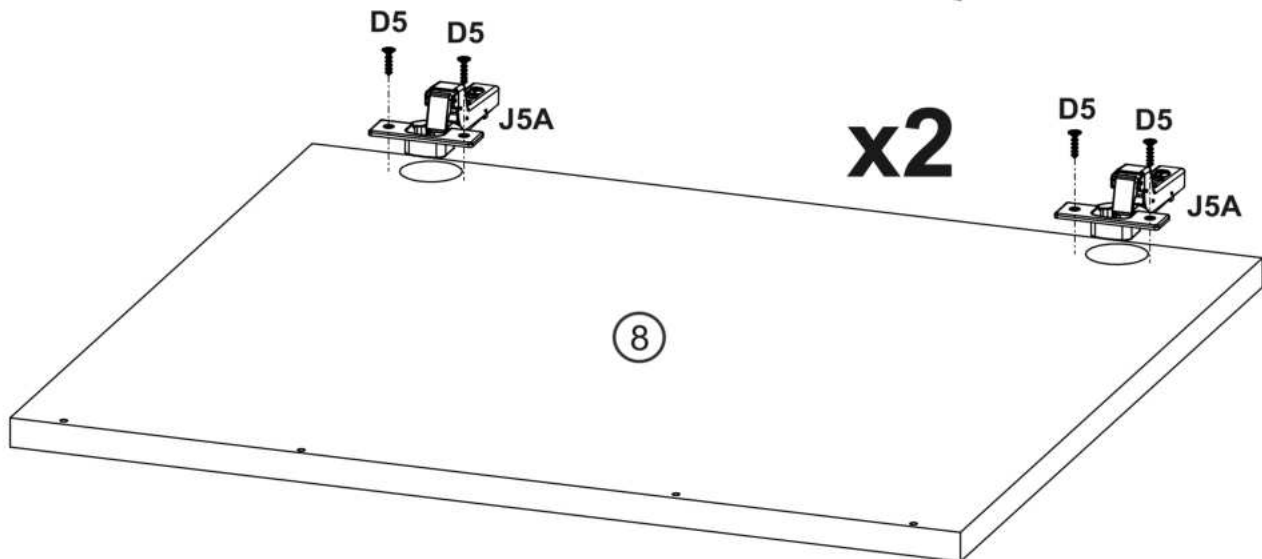
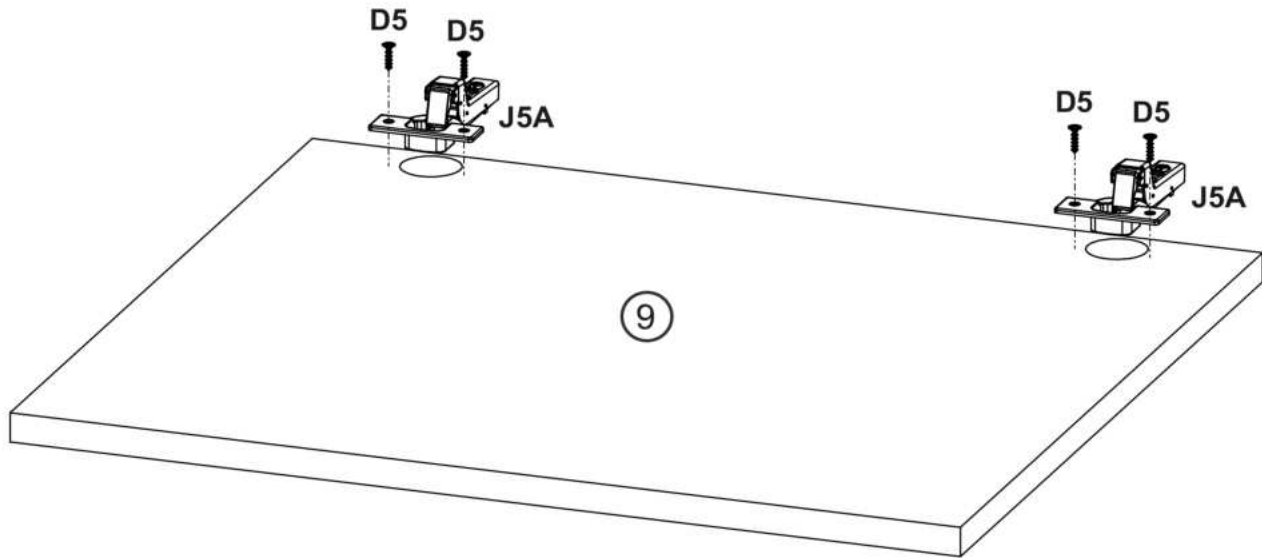
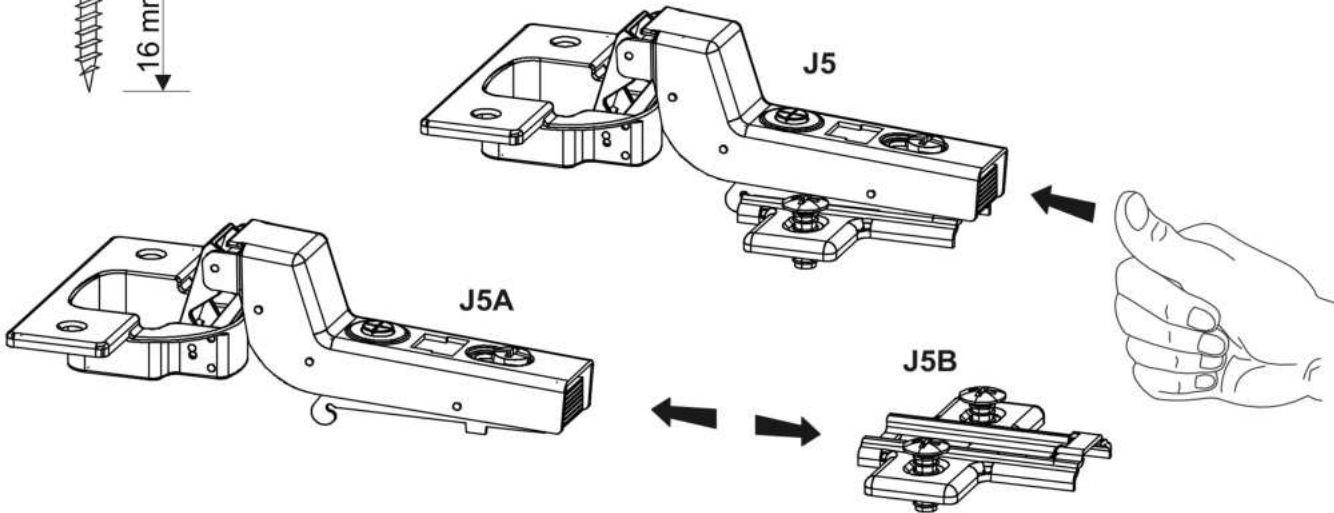
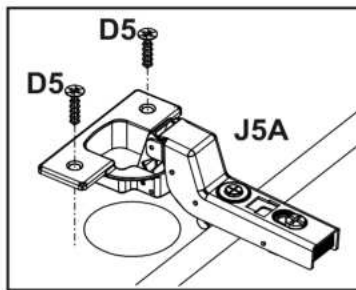
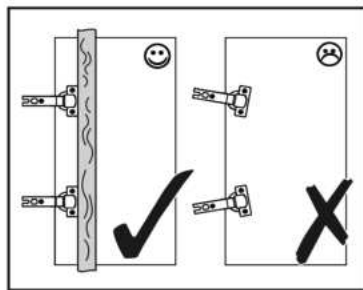

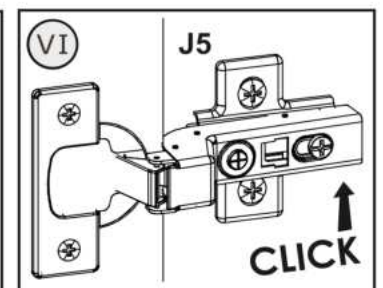
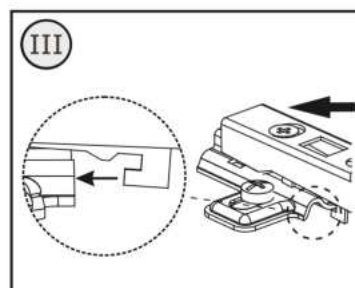
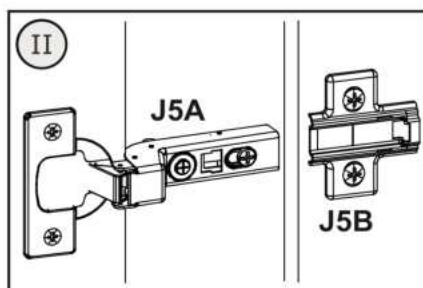
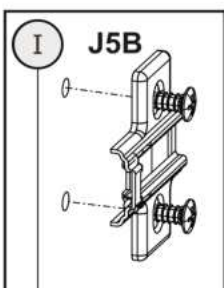
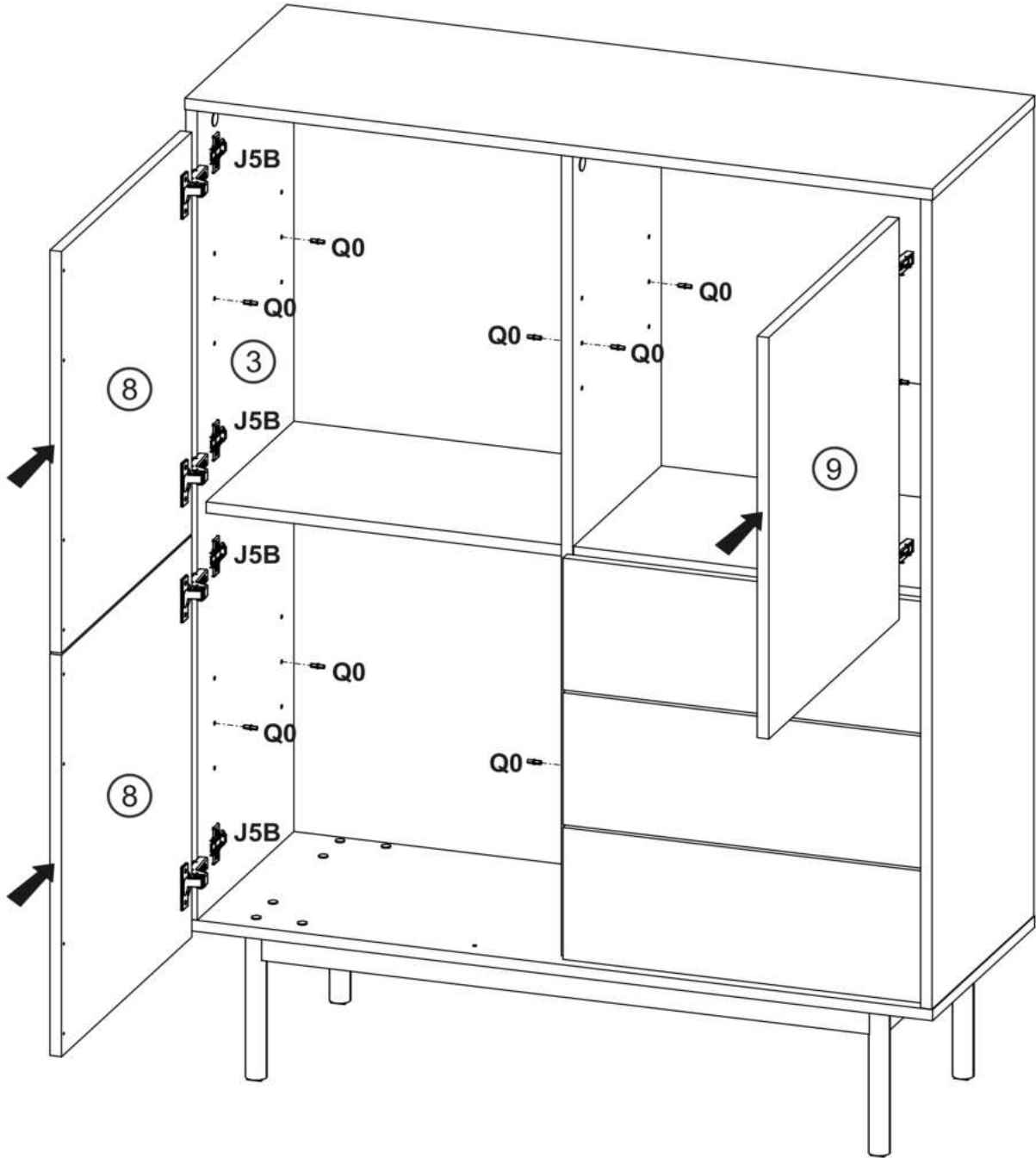
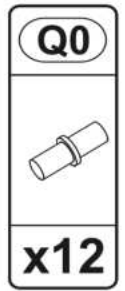
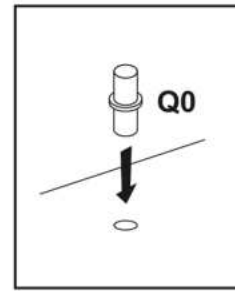



# 15

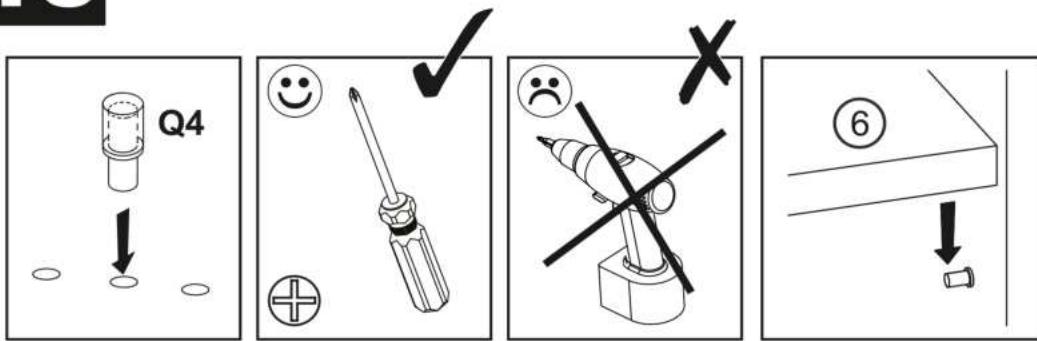

<b>D4</b>  3.5x16 <b>x4</b>	<b>L21</b>  <b>x2</b>	<b>Q4</b>  <b>x3</b>
--------------------------------------	-----------------------------	----------------------------

3x15



**D0**

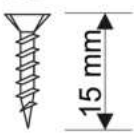

3.5x16



**D5**

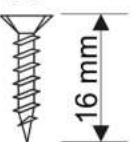

3,5x16



**D4**

