



Bezpečnostní pokyny

- ⚠ Pro zabránění řezným zraněním a pohmožděninám je nutné při montáži nosit rukavice.
- ⚠ Produkt smí být používán pouze ke koupání a za účelem tělesné hygieny.
- ⚠ Děti a dospělé osoby s tělesným, duševním a / nebo smyslovým postižením nesmí produkt používat bez dozoru. Osoby pod vlivem alkoholu nebo drog nesmí produkt používat.
- ⚠ Je nutné vyrovnat velké rozdíly tlaku mezi přípoji studené a teplé vody.

Pokyny k montáži

- Před montáží je třeba produkt zkontrolovat, zda nebyl při transportu poškozen. Po zabudování nebudou uznány žádné škody způsobené transportem nebo poškození povrchu.
- Vedení a armatura musí být namontovány, propláchnuty a otestovány podle platných norem.
- Je třeba dodržovat montážní pravidla platné v dané zemi.

Technické údaje

Provozní tlak:	max. 1 MPa
Doporučený provozní tlak:	0,1 - 0,5 MPa
Zkušební tlak:	1,6 MPa
	(1 MPa = 10 bar = 147 PSI)
Teplota horké vody:	max. 60 °C
Tepelná desinfekce:	70 °C / 4 min

- Vlastní čištění proti zpětnému nasátí.
- Výrobky Hansgrohe jsou vhodné pro přímý kontakt s pitnou vodou.

Popis symbolů



Nepoužívat silikon s obsahem kyseliny octové!

max. $\approx 42^{\circ}\text{C}$ Safety Function (viz strana 66)

Díky Safety Function je možné předem nastavit nejvyšší požadovanou teplotu, např. max. 42°C.



Nastavení (viz strana 66)

Po ukončení montáže se musí zkontrolovat teplota vody vytékající z termostatu. Pokud se teplota změřená v místě odběru liší od teploty nastavené na termostatu, je nutné provést korekci.



Údržba (viz strana 68)

- U zpětných ventilů se musí podle EN 806-5 v souladu s národními nebo regionálními předpisy testovat jejich funkčnost (alespoň jednou ročně).

- Aby byl zajištěn lehký chod regulační jednotky, měl by se termostat čas od času nastavit na úplně horkou a úplně studenou vodu.



Rozměry (viz strana 70)



Diagram průtoku (viz strana 70)

volný průtok



Servisní díly (viz strana 71)

XXX = Kód povrchové úpravy

000 = Chrom

250 = Chrom/Zlato Oc'el

300 = Stainless Steel Optic



Zvláštní příslušenství (viz strana 71)

není součástí dodávky

- prodloužení 25 mm #13595000
- prodloužení 22 mm (při malé hloubce zabudování) #13593000; #13597XXX; #13597XXX
- vyrovnávací sada 1° #95521000



Čištění (viz strana 76)



Ovládání (viz strana 75)



Zkušební značka (viz strana 76)



Porucha	Příčina	Odstranění
Málo vody	<ul style="list-style-type: none"> - Nízký tlak v přívodu. - Zanesený lapač nečistot v regulační jednotce - Sítko v těsnění u sprchy zanesené 	<ul style="list-style-type: none"> - Zkontrolovat tlak v potrubí - Vyčistit lapače nečistot před termostatem a na regulační jednotce - Vyčistit sítko v těsnění mezi sprchou a hadicí
Křížení toků, teplá voda se při zavřené armatuře tlačí do přívodu studené vody nebo naopak	<ul style="list-style-type: none"> - Znečištěný nebo netěsný zpětný ventil 	<ul style="list-style-type: none"> - Zpětný ventil vyčistit, případně vyměnit
Teplota u výtoku nesouhlasí s nastavenou teplotou	<ul style="list-style-type: none"> - Teplota u výtoku nesouhlasí s nastavenou teplotou - Nízká teplota teplé vody 	<ul style="list-style-type: none"> - Nastavit termostat - Teplotu horké vody zvýšit na 42°C až 60°C
Nelze regulovat teplotu	<ul style="list-style-type: none"> - regulační jednotka zanesena vodním kamenem - U nové instalace: obráceně připojené základní těleso (má být studená vpravo, teplá vlevo) nebo zabudované otočené o 180° 	<ul style="list-style-type: none"> - vyměnit regulační jednotku - Funkční blok zabudovat otočený o 180°
Tlačítko bezpečnostní pojistky je nefunkční	<ul style="list-style-type: none"> - Vadná pružina - Tlačítko zanesené vodním kamenem 	<ul style="list-style-type: none"> - Pružinu nebo tlačítko očistit a lehce pořířit tukem, případně vyměnit
Ciężka praca zaworu sprcha nebo výtok odkapává	<ul style="list-style-type: none"> - horní uzavírací prvek poškozen - Nečistoty nebo usazeniny na těsnicím sedle 	<ul style="list-style-type: none"> - vyměnit horní uzavírací prvek - vyčistit resp. vyměnit horní uzavírací prvek

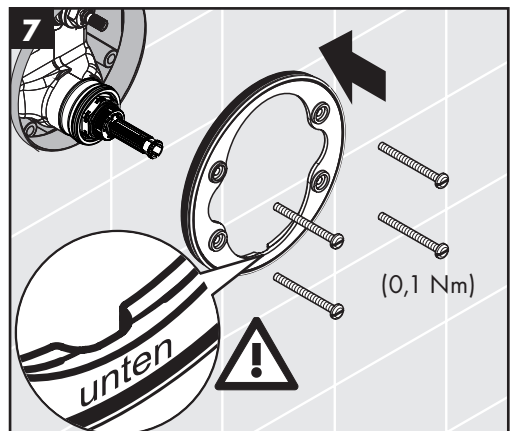
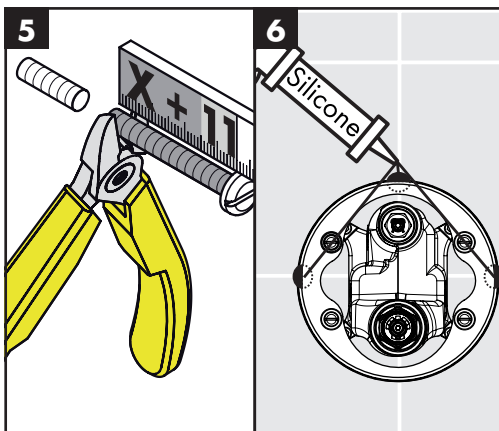
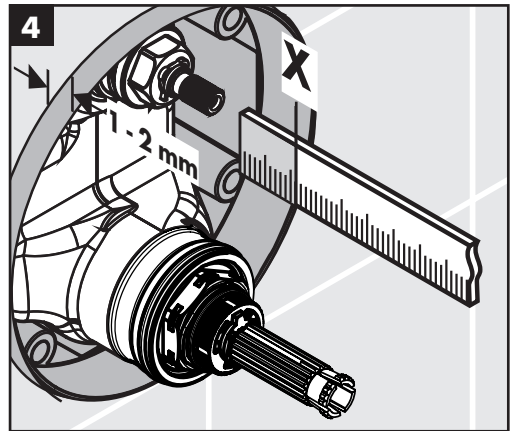
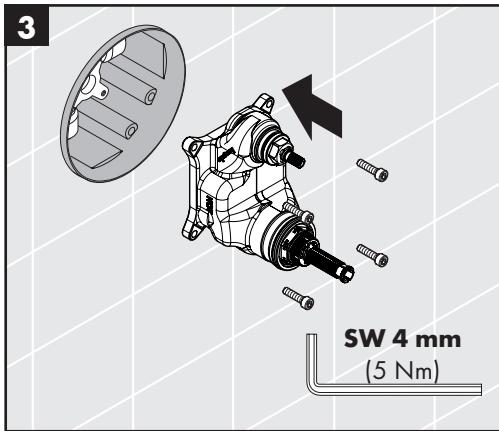
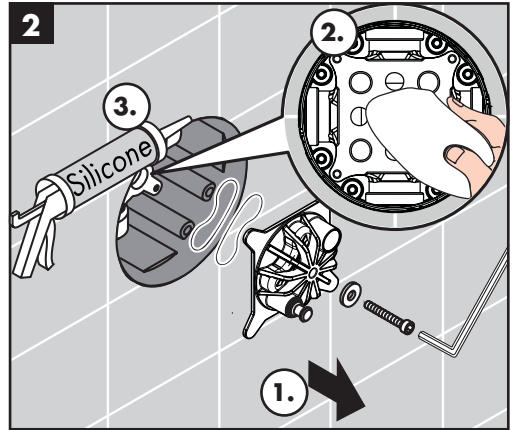
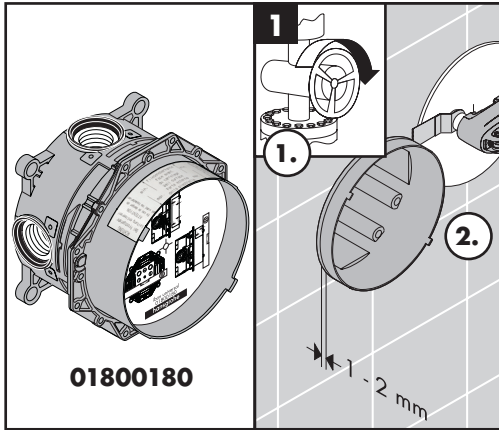

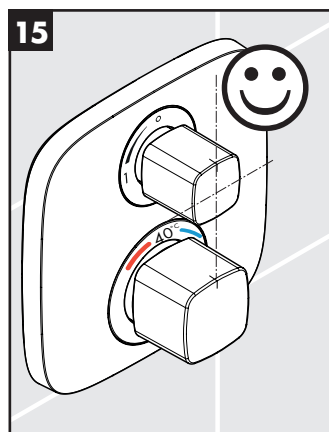
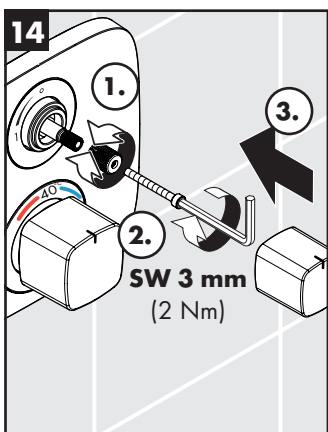
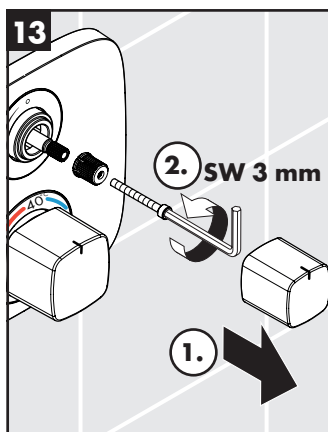
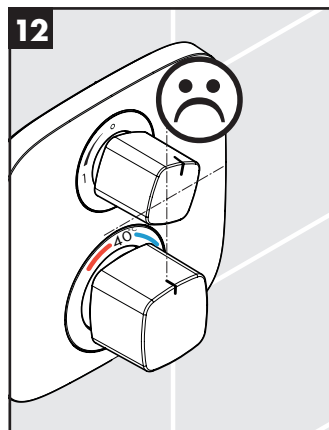
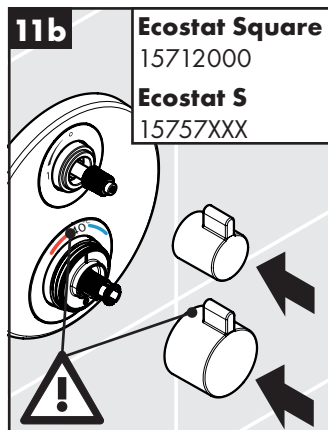
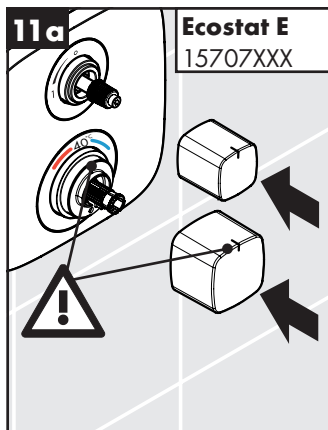
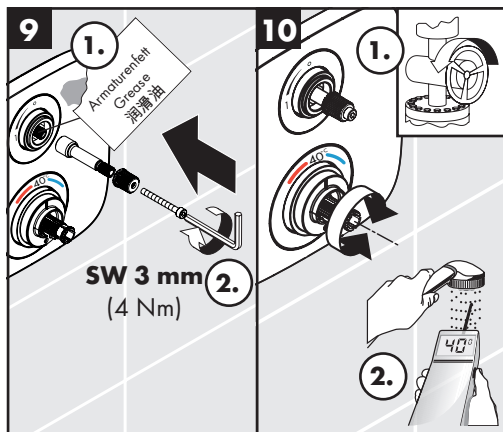
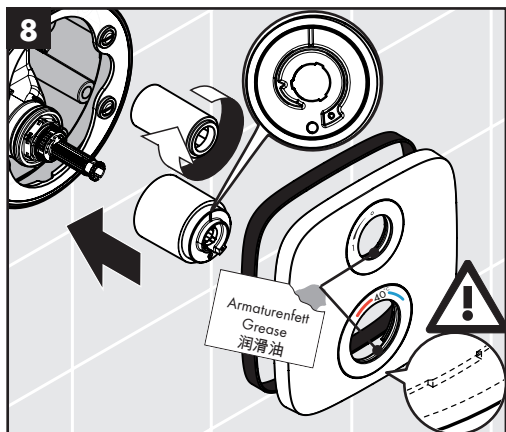

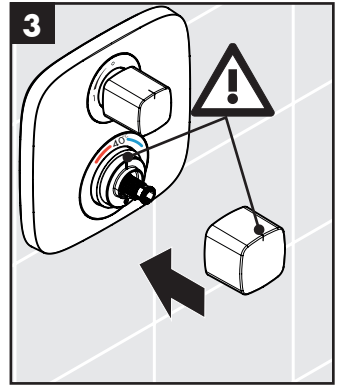
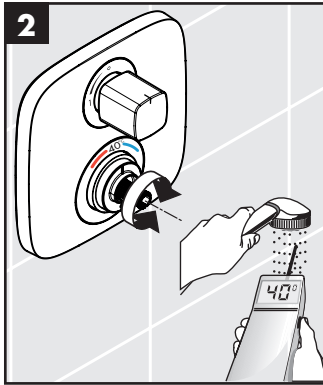
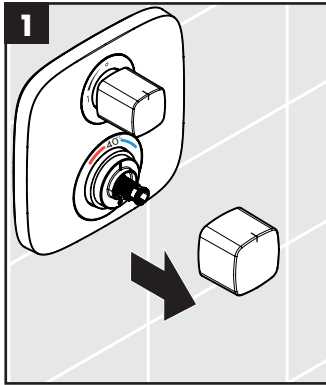

max.
≈ 42 °C

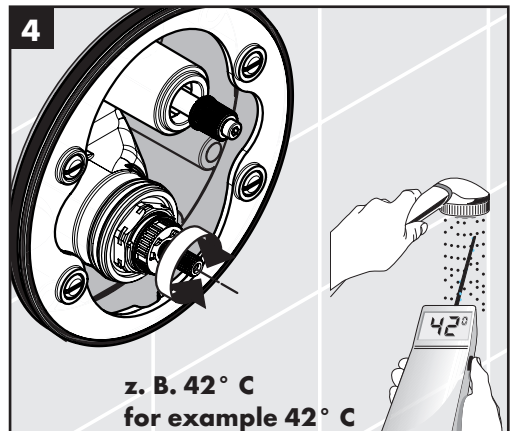
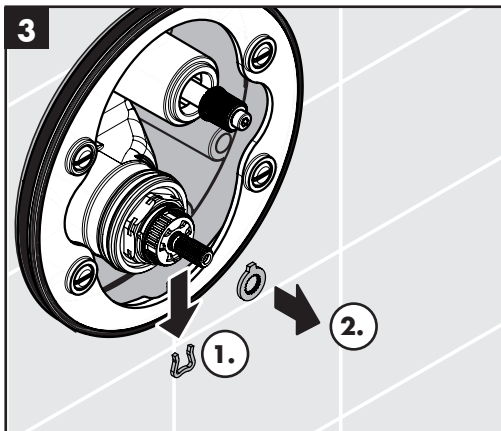
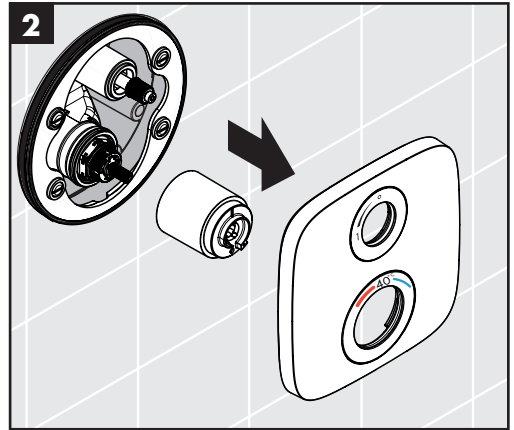
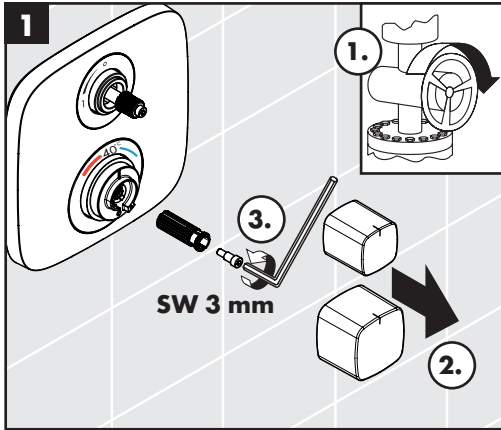

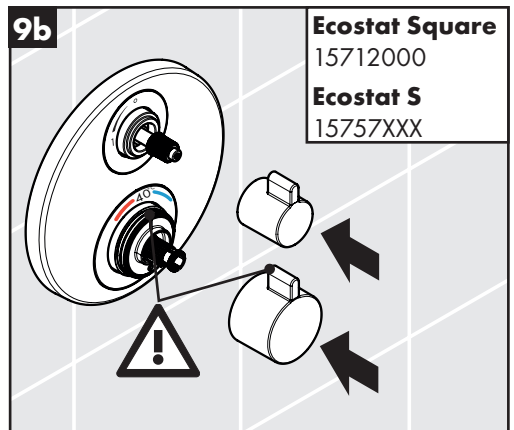
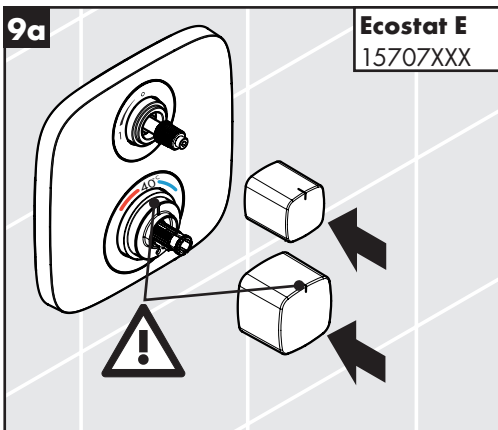
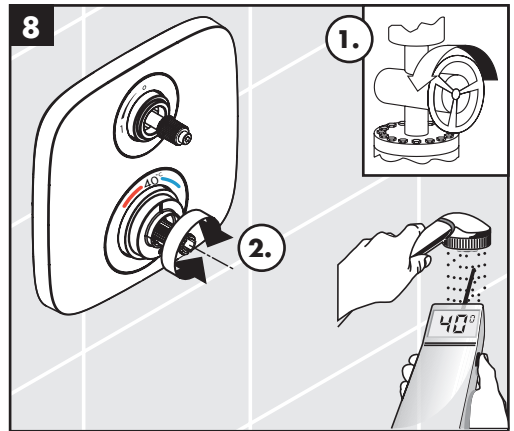
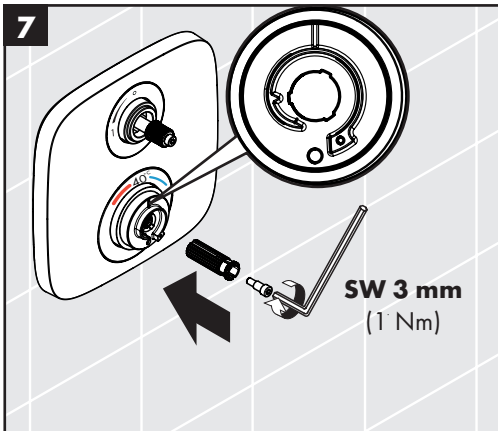
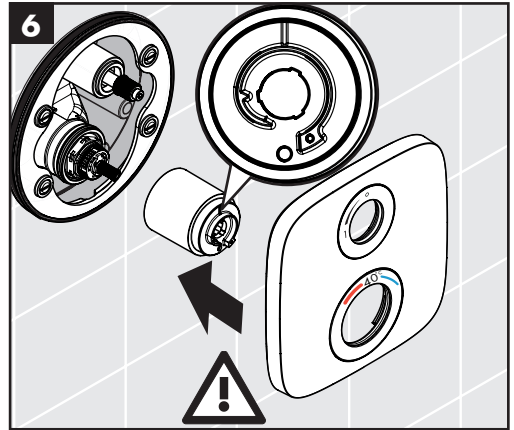
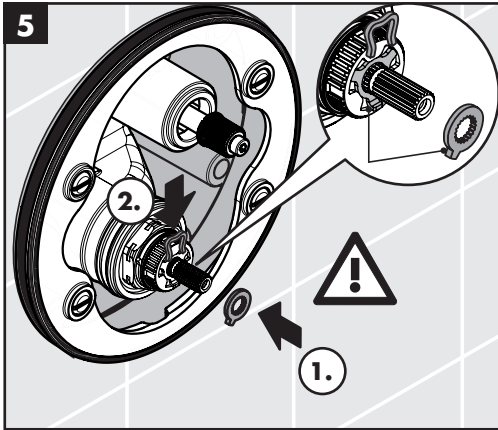

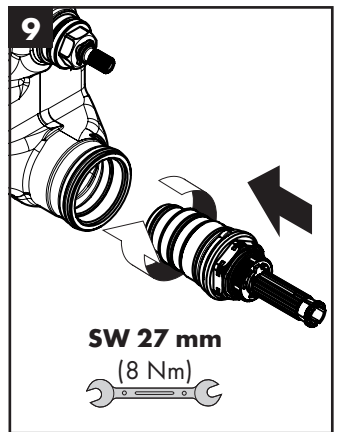
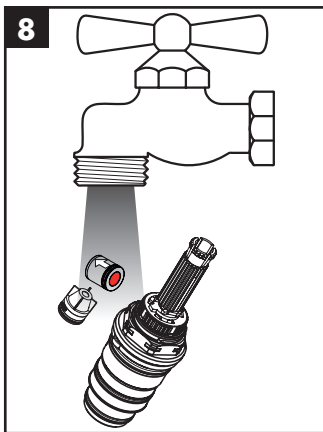
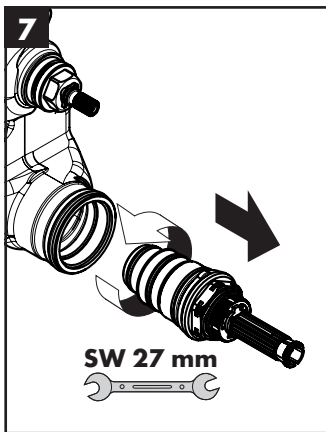
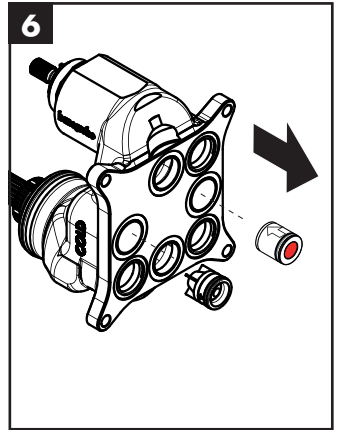
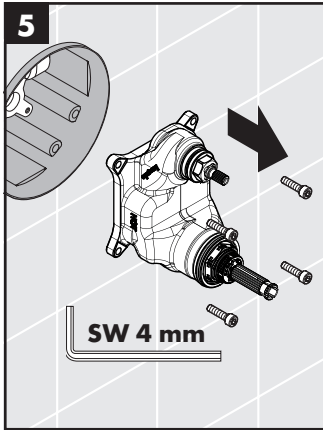
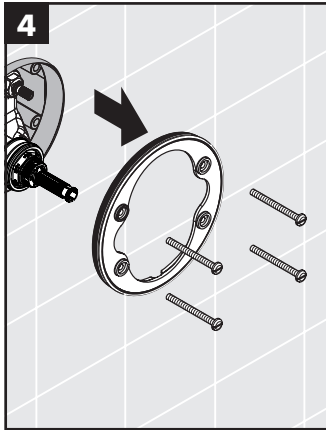
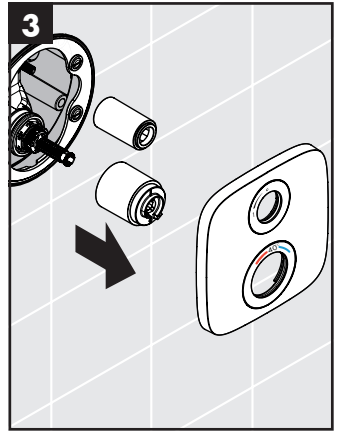
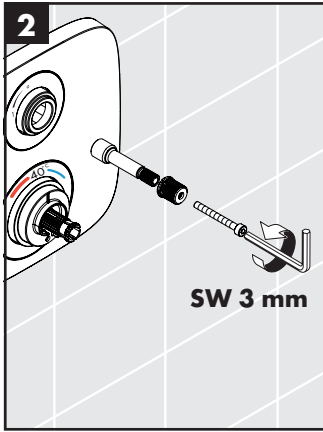
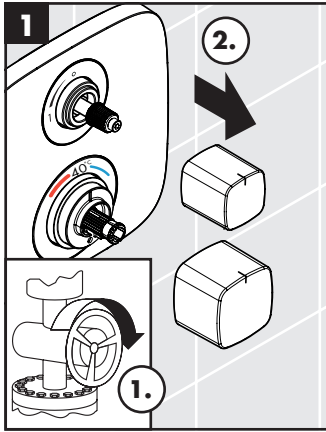



10

Rot / Rouge / Red / Rosso / Rojo / Rood / Rød / Vermelho / Czerwony / Červená / Červená / 红色 / Красный / Punainen / Röd / Raudona / Crvena / Roşu / Kókkivo / Rdeča / Punane / Sarkana / Crvena / Rød / Червено / Red / E Kuqe / أحمر / Kırmızı / Piros / ДИТК

11

SW 4 mm
(5 Nm)

12

(0,1 Nm)

unten

13

Armaturenfett
Grease
润滑油

14

Armaturenfett
Grease
润滑油

SW 3 mm
(4 Nm)

15

1.

2.

16



Ecostat E
15707XXX

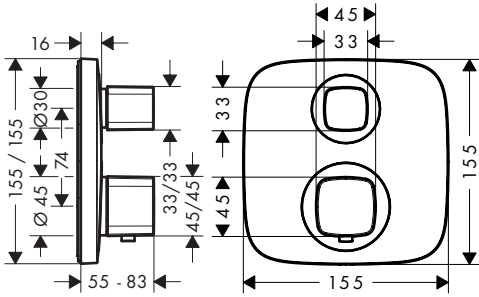

Ecostat S
15757XXX

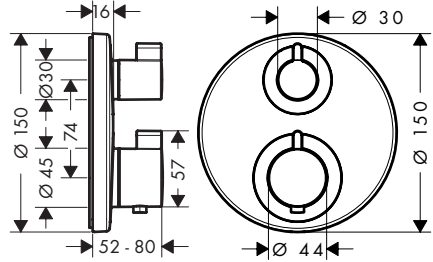

Ecostat Square
15712000

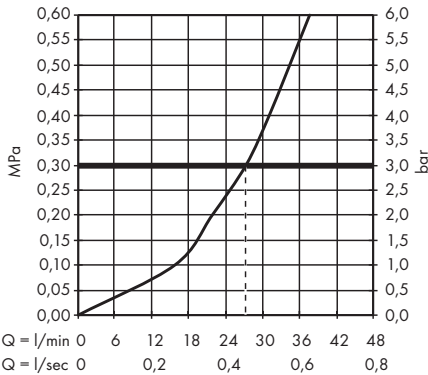
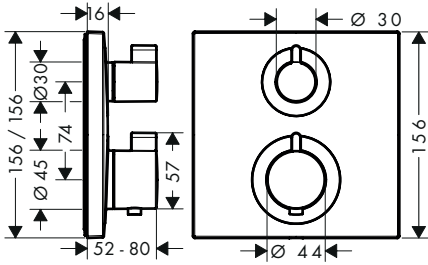



Ecostat E

15707XXX

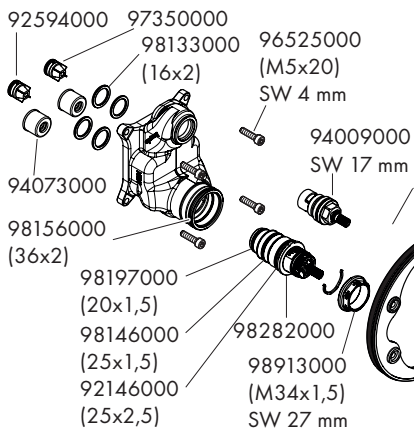

Ecostat Square

15712000

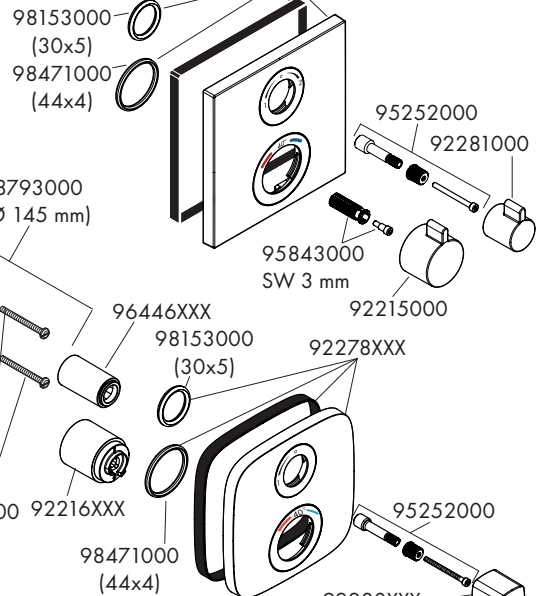

Ecostat S

15757XXX

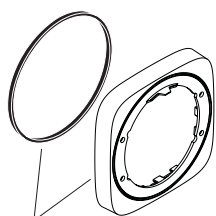
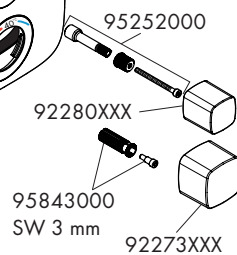
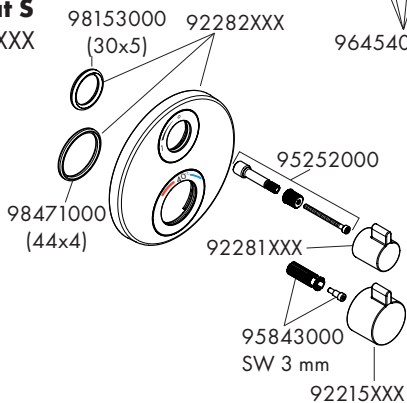

15597XXX (22 mm)

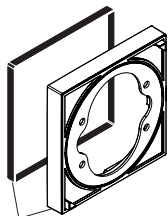

13593000 (22 mm)

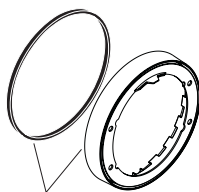

13597XXX (22 mm)

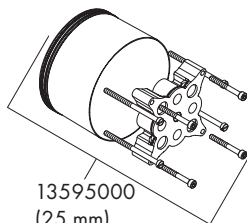

13595000 (25 mm)

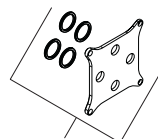

95521000 (1°)



On the following pages 72 - 75 you can find important information only for the installation in UK

Safety and Important Information

Hansgrohe products are safe provided they are installed, used and maintained in accordance with these instructions and recommendations.

Please read these instructions thoroughly and retain for future use.

The plumbing installation of this thermostat mixing valve must comply with the requirements of UK.

Water Regulations/Bylaws (Scotland), Building Regulations or any other regulations specified by the local Water Authority and supplier.

The installation of thermostatic mixing valves must comply with the requirements of the Water Supply (Water Fittings) Regulations 1999.

We strongly recommend that you use a plumber registered with or a member of an Association:

Chartered Institute of Plumbing and Heating Engineering (CIPHE)

Water Industry Approved Plumber Scheme (WIAPS)

Dispose of plastic bags carefully.

Keep children well away from the work area.

Check for hidden pipes and cables in the wall before drilling holes.

The unit must be mounted on a finished waterproofed wall surface (usually tiles).

If you are using power tools (e.g. to drill holes) wear safety glasses and always disconnect tools from the power supply after use.

Do not operate the shower unit if the hand shower or spray hose has been damaged or is blocked.

Do not block the flow of water from the hand shower, by placing it on your hand or any other part of your body or foreign object.

The thermostatic unit should be serviced annually by a qualified person to ensure maximum safety during use.

The thermostatic mixing valve will be installed in such a position that maintenance of the TMV and its valves

and the commissioning and testing of the TMV can be undertaken.

The mixer is fitted with check valves (page 71 pos. 92594000 and 97350000). There are filters on the thermostatic element too (page 71 pos. 98282000).

The fitting of isolation valves is required (preferred location page 73 Installation Requirements).

Technical Hotline (for UK only)

Tel: 01372465655

Email: Technical@hansgrohe.co.uk

(Diese Servicehotline ist nur für das Vereinigte Königreich Großbritannien, nicht z. B. für Deutschland)

Technical Data

This thermostatic valve will suit supplies of:

HIGH PRESSURE (HP-S / HP-T)

Type 3 High Pressure shower HP-S only

Type 2 High Pressure shower or tub as appropriate HP-S and or HP-T

Operating pressure: max. 10 bar

Recommended operating pressure: 1 - 5 bar

Test pressure: 16 bar

Hot water temperature: max. 60 °C

Recommended hot water temp.: 55 - 60 °C

Rate of flow: 26 l/min. @ 3 bar

Maximum outlet temperature: 43 °C +/- *

Safety check: 40 °C

Hot water connection: Left hand

Cold water connection: Right hand

Mixed water temperature

Application Mixed water temperature (at point of discharge).

Shower 41 °C max.

Washbasin 41 °C max.

Bath (44 °C fill) 44 °C max.

Minimum difference between hot water and mixed water temperature: 6 K

Hot and cold supply pressure should be balanced

* For preset outlet temperature adjustment - See page 66.

NB. If a water supply is fed by gravity then the supply pressure should be verified to ensure the conditions of use are appropriate for the valve.

Recommended outlet temperatures

The TMV scheme recommends the following set maximum mixed water outlet temperatures for use in all premises:

44 °C for bath fill but see notes below;

41 °C for showers;



41 °C for washbasins.

The maximum mixed water temperature can be 2 °C above the recommended maximum set outlet temperatures.

Note: 46 °C is the maximum mixed water temperature from the bath tap. The maximum temperature takes account of the allowable temperature tolerances inherent in thermostatic mixing valves and temperature losses in metal baths.

It is not a safe bathing temperature for adults or children. The British Burns Association recommends 37 to 37.5 °C as a comfortable bathing temperature for children. In premises covered by the Care Standards Act 2000, the maximum mixed water outlet temperature is 43 °C.

Installation Requirements

This thermostatic mixer valve must be installed in compliance with current Water Regulations. If you have any doubts about the Water Regulation requirements contact your local water services provider or use the services of a professional plumber.

This mixer valve is suitable for use with the following water supply systems:

- Gas Combination Boiler (multi-point) 1.0 - 10 bar*
- Unvented System (pressure balanced) 1.0 - 10 bar
- Pumped System 1.0 - 10 bar

IMPORTANT: If you install this mixer with a gravity fed system, there must be a minimum head (vertical distance) from the underside of the cold water storage tank to the showerhead position of at least 5 metre.

Before connecting the mixer, water should be flushed through the system to remove all debris that might otherwise damage the valve.

* If pressure is in excess of 3.5 bar, a pressure-reducing valve should be fitted.

Supply Conditions TMV Type 2

Operating pressure range	High pressure
Maximum static pressure - bar	10
Flow pressure, hot and cold - bar	0.5 to 5
Hot supply temperature - °C	55 to 65
Cold supply temperature - °C	5 to 25

Supply Conditions TMV Type 3

Operating pressure range	High pressure
Maximum static pressure - bar	10
Flow pressure, hot and cold - bar	1 to 5
Hot supply temperature - °C	55 to 65
Cold supply temperature - °C	5 to 20

Valves operating outside these conditions cannot be guaranteed to operate as Type 2 or Type 3 valves.

Commissioning and in-service tests

Commissioning

Purpose

Since the installed supply conditions are likely to be different from those applied in the laboratory tests it is appropriate, at commissioning, to carry out some simple checks and tests on each mixing valve to provide a performance reference point for future in-service tests.

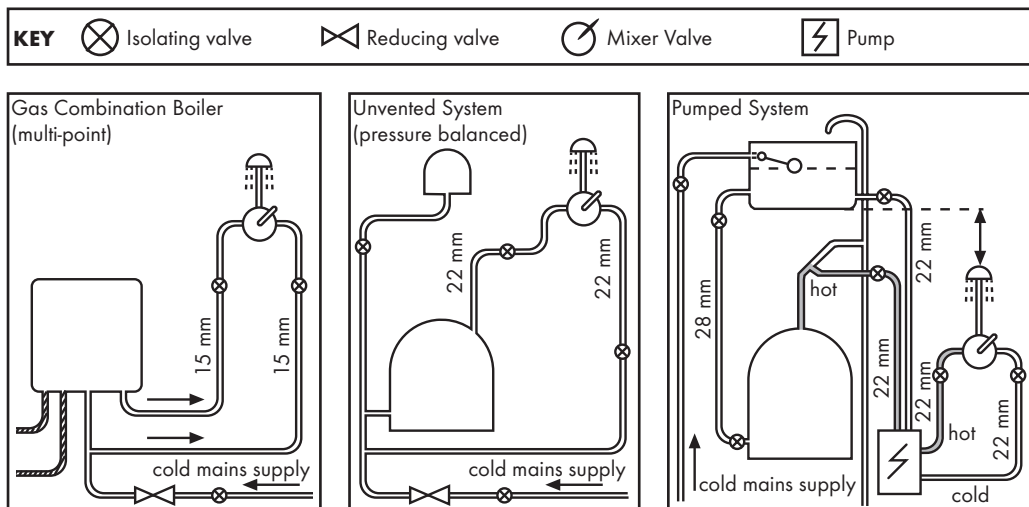

Procedure

1. Check that:
 - a) the designation of the thermostatic mixing valve matches the intended application
 - b) the supply pressures are within the range of operating pressures for the designation of the valve
 - c) the supply temperatures are within the range permitted for the valve and by guidance information on the prevention of legionella etc.
2. Adjust the temperature of the mixed water in accordance with the manufacturer's instructions (page 66) and the requirement of the application and then carry out the following sequence:
 - a) record the temperature of the hot and cold water supplies
 - b) record the temperature of the mixed water at the largest draw-off flow rate
 - c) record the temperature of the mixed water at a smaller draw-off flow rate, which shall be measured
 - d) isolate the cold water supply to the mixing valve and monitor the mixed water temperature
 - e) record the maximum temperature achieved as a result of (d) and the final stabilised temperature

NOTE: The final stabilised mixed water temperature should not exceed the values in Table A.

- f) record the equipment, thermometer etc. used for the measurements

Table A: Guide to maximum stabilised temperatures recorded during site tests

Application	Max. mixed water temperature
Shower	43 °C
Washbasin	43 °C
Bath (44 °C fill)	46 °C

The mixed water temperature at terminal fitting should never exceed 46°C.

If there is a residual flow during the commissioning or the annual verification (cold water supply isolation test), then this is acceptable providing the temperature of the water seeping from the valve is no more than 2 °C above the designated maximum mixed water outlet temperature setting of the valve.

Temperature readings should be taken at the normal flow rate after allowing for the system to stabilise.

The sensing part of the thermometer probe must be fully submerged in the water that is to be tested.

Any TMV that has been adjusted or serviced must be re-commissioned and re-tested in accordance with the manufacturers' instructions.

In-service tests

Purpose

The purpose of in-service tests is to regularly monitor and record the performance of the thermostatic mixing valve. Deterioration in performance can indicate the need for service work on the valve and/ or the water supplies.

Procedure

1. Carry out the procedure 1. (a) to (c) and 2. (a) to (e) on page 74 using the same measuring equipment, or equipment to the same specifications.
2. If the mixed water temperature has changed significantly from the previous test results (e.g. > 1 K), record the change and before re-adjusting the mixed water temperature check:
 - a) that any in-line or integral strainers are clean
 - b) any in-line or integral check valves or other anti-backsiphonage devices are in good working order
 - c) any isolating valves are fully open
3. With an acceptable mixed water temperature, complete the procedure 2. (a) to (e) on page 74.
4. If at step 2. (e) on page 74 the final mixed water temperature is greater than the values in Table A and / or the maximum temperature exceeds the corresponding value from the previous test results by more than about 2 K, the need for service work is indicated.

NOTE: In-service tests should be carried out with a frequency which identifies a need for service work before an unsafe water temperature can result. In the absence of any other instruction or guidance, the procedure described in „Frequency of in-service tests“ may be used.

Frequency of in-service tests TMV Type 3*

General

In the absence of any other instruction or guidance on the means of determining the appropriate frequency of in-service testing, the following procedure may be used:

1. 6 to 8 weeks after commissioning carry out the tests given in 2. on page 74.
2. 12 to 15 weeks after commissioning carry out the tests given in 2. on page 74.

3. Depending on the results of 1. and 4. several possibilities exist:
- If no significant changes (e.g. < 1 K) in mixed water temperatures are recorded between commissioning and 1., or between commissioning and 4. the next in-service test can be deferred to 24 to 28 weeks after commissioning.
 - If small changes (e.g. 1 to 2 K) in mixed water temperatures are recorded in only one of these periods, necessitating adjustment of the mixed water temperature, then the next in-service test can be deferred to 24 to 28 weeks after commissioning.
 - If small changes (e.g. 1 to 2 K) in mixed water temperatures are recorded in both of these periods, necessitating adjustment of the mixed water temperature, then the next in-service test should be carried out at 18 to 21 weeks after commissioning.
 - If significant changes (e.g. > 2 K) in mixed water temperatures are recorded in either of these periods, necessitating service work, then the next in-service test should be carried out at 18 to 21 weeks after commissioning.
4. The general principle to be observed after the first 2 or 3 in-service tests is that the intervals of future tests should be set to those which previous tests have shown can be achieved with no more than a small change in mixed water temperature.

***TMV Type 2: The frequency of performing the in-service tests is 1 year maximum.**

Thermostatic Adjustment

Temperature Limitation

The temperature is limited by the safety stop to 40°C . If a higher temperature is required, it is possible to override the safety stop by depressing the safety button.

NB. It is recommended that for private domestic use the maximum mixed water temperature be set at the following factory set values:

Shower Mixer 43°C

Bath/Shower 43°C

For healthcare applications the Temperatures must be set by following the procedures on page 66. This ensures that after correct installation the outlet temperature of the water can never exceed 43°C .

Temperatures can be set by following the procedures on page 66. This ensures that after correct installation the outlet temperature of the water can never exceed 43°C .

To guarantee a smooth running of the thermostatic element, it is necessary from time to time to turn the thermostat from total hot to total cold. The thermostatic mixer valve should be checked annually by a qualified person to ensure correct operation.

The mixer is fitted with check valves (page 71 pos. 92594000 and 97350000) and filters (page 71 pos 98282000). If the water flow drops the filters need to be cleaned. For that purpose please follow the steps 1 - 16 on page 68.

Calibrating Thermostat

If the temperature reading is different to the showering temperature, follow the steps 1 - 3 on page 66.

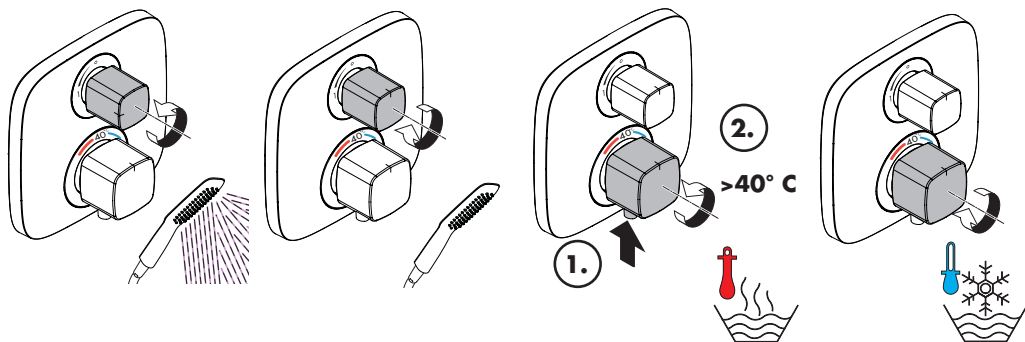



www.hansgrohe.com/cleaning-recommendation

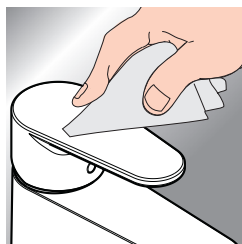

- DE** Reinigungsempfehlung / Garantie / Kontakt
- FR** Recommandation pour le nettoyage / Garanties / Contact
- EN** Cleaning recommendation / Warranty / Contact
- IT** Raccomandazione di pulizia / Garanzia / Contatto
- ES** Recomendaciones para la limpieza / Garantía / Contacto
- NL** Aanbevelingen inzake reiniging / Garantie / Contact
- DK** Rengøringsvejledning / Garanti / Kontakt
- PT** Recomendações de limpeza / Garantia / Contacto
- PL** Zalecenie dotyczące pielęgnacji / Gwarancja / Kontakt
- CS** Doporučení k čištění / Záruka / Kontakt
- SK** Odporúčania pre čistenie / Záruka / Kontakt
- ZH** 清洁指南 / 担保 / 接触
- RU** Рекомендации по очистке / Гарантия / Контакты
- FI** Puhdistussuositus / Takuu / Kosketus

- SV** Rengöringsrekommendationer / Garanti / Contacto
- LT** Valymo rekomendacijos / Garantija / Kontaktai
- HR** Preporuke za čišćenje / Garancija / Kontakt
- RO** Recomandări pentru curățare / Garanție / Contact
- EL** Σύσταση καθαρισμού / Εγγύηση / επαφή
- SL** Priporočilo za čiščenje / Garancija / Kontakt
- ET** Puhastussoovitused / Garantii / Kontakt
- LV** Tīrīšanas ieteikumi / Garantija / Kontakti
- SR** Preporuke za čišćenje / Garancija / Kontakt
- NO** Anbefaling for rengjøring / Garanti / Kontakt
- BG** Препоръка за почистване / Гаранция / Контакт
- JP** お手入れの方法 / 保証について / ご連絡先
- SQ** Këshilla rreth pastrimit / Garancia / Kontakt
- AR** توصيات التنظيف / الضمان / اتصال
- TR** Temizleme önerisi / Garanti / Temas
- HU** Tisztítási tanácsok / Garancia / érintkezés
- HE** המלצות לניקוי / אחריות / איש קשר



	P-IX	DVGW SINTEF NF	STF CERTIFICATION AGOD KINA	ETA	GODKENDT TIL DRINKEVAND
15707XXX	PA-IX 28384/IB		X	X	X
15712000	PA-IX 28384/IB		X	X	X
15757XXX	PA-IX 28384/IB		X	X	X



hansgrohe

Hansgrohe · Auestraße 5 · 9 · D-77761 Schiltach · Telefon +49 (0) 78 36/51-1282 · Telefax +49 (0) 7836/511440
E-Mail: info@hansgrohe.com · Internet: www.hansgrohe.com