

Bezpečnostní pokyny

- ⚠ Pro zabránění řezným zraněním a pohmožděninám je nutné při montáži nosit rukavice.
- ⚠ Produkt smí být používán pouze ke koupání a za účelem tělesné hygieny.
- ⚠ Děti a dospělí osoby s tělesným, duševním a / nebo smyslovým postižením nesmí produkt používat bez dozoru. Osoby pod vlivem alkoholu nebo drog nesmí produkt používat.
- ⚠ Je nutné vyrovnat velké rozdíly tlaku mezi přípoji studené a teplé vody.

Pokyny k montáži

- Před montáží je třeba produkt zkontrolovat, zda nebyl při transportu poškozen. Po zabudování nebudou uznány žádné škody způsobené transportem nebo poškození povrchu.
- Vedení a armatura musí být namontovány, propláchnuty a otestovány podle platných norem.
- Je třeba dodržovat montážní pravidla platné v dané zemi.
- Výrobek není určen k použití ve spojení s parní lázní!

Termostat v kombinaci s průtokovými ohřívači

- Má-li být připojena ruční sprcha, pak z ní musí být vymontována případně zabudován škrtkový ventil.
- Při problémech s průtokovým ohřívačem nebo většími rozdíly tlaku se musí do přívodu studené vody zabudovat škrtkový ventil (kat.č.97510000), který je k dostání jako opce.
- Termostat Sprcha: V kombinaci s průtokovými ohřívači se musí odstranit ECOSTOP dorazový kroužek (#95042000).

Technické údaje

Provozní tlak:	max. 1 MPa
Doporučený provozní tlak:	0,1 - 0,5 MPa
Zkušební tlak:	1,6 MPa (1 MPa = 10 bar = 147 PSI)
Teplota horké vody:	max. 70 °C
Doporučená teplota horké vody:	65 °C

Rozteč připojení:	150±12 mm
Přípoje G 1/2:	studená vpravo - teplá vlevo
Teplotná desinfekce:	max. 70 °C / 4 min

- Vlastní čištění proti zpětnému nasátí.
- Výrobky Hansgrohe jsou vhodné pro přímý kontakt s pitnou vodou.

Popis symbolů

 Nepoužívat silikon s obsahem kyseliny octové!

max. ≈ 42 °C Safety Function (viz strana 32)

Díky Safety Function je možné předem nastavit nejvyšší požadovanou teplotu, např. max. 42 °C.

Nastavení (viz strana 32)

Po ukončení montáže se musí zkontrolovat teplota vody vytékající z termostatu. Pokud se teplota změřená v místě odběru liší od teploty nastavené na termostatu, je nutné provést korekci.

ECO ≈ 10 l ECOSTOP (viz strana 33)

Údržba (viz strana 33)

- U zpětných ventilů se musí podle DIN EN 1717 v souladu s národními nebo regionálními předpisy testovat jejich funkčnost (alespoň jednou ročně).
- Aby byl zajištěn lehký chod regulační jednotky, měl by se termostat čas od času nastavit na úplně horkou a úplně studenou vodu.

Rozměry (viz strana 35)

Diagram průtoku (viz strana 35)

Servisní díly (viz strana 36)

Čištění (viz strana 37)

Ovládání (viz strana 34)

Zkušební značka (viz strana 36)

Porucha	Příčina	Odstranění
Málo vody	- Nízký tlak v přívodu. - Zanesený lapač nečistot v regulační jednotce	- Zkontrolovat tlak v potrubí - Vyčistit lapače nečistot před termostatem a na regulační jednotce
Křížení toků, teplá voda se při zavřené armatuře tlačí do přívodu studené vody nebo naopak	- Sítko v těsnění u sprchy zanesené - Znečištěný nebo netěsný zpětný ventil	- Vyčistit sítko v těsnění mezi sprchou a hadicí - Zpětný ventil vyčistit, případně vyměnit
Teplota u výtoku nesouhlasí s nastavenou teplotou	- Teplota u výtoku nesouhlasí s nastavenou teplotou - Nízká teplota teplé vody	- Nastavit termostat - Teplotu horké vody zvýšit na 42 °C až 65 °C
Nelze regulovat teplotu průtokový ohřívač v provozu s termostatem nezapne	- regulační jednotka zanesena vodním kamenem - Sítko na zachycování nečistot je zanesené - Zpětný ventil je zablokovaný - Není odstraněn kroužek ze sprchy - Nečistoty nebo usazeniny na těsnícím sedle	- vyměnit regulační jednotku - Vyčistit případně vyměnit sítko - Vyměnit zpětný ventil - Odstranit kroužek ze sprchy - vyčistit resp. vyměnit horní uzavírací prvek
sprcha nebo výtok odkapává	- není vymontován dorazový kroužek Ecoston (#95042000)	- demontovat dorazový kroužek (#95042000)

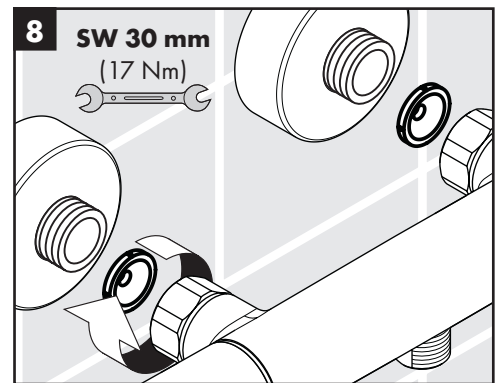
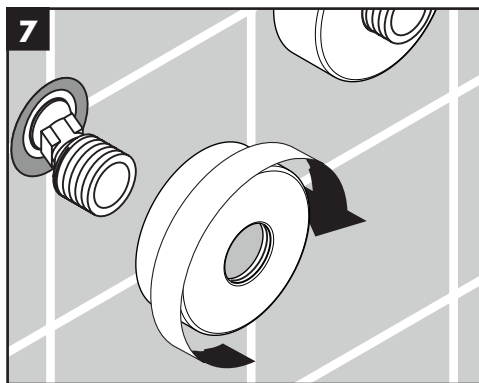
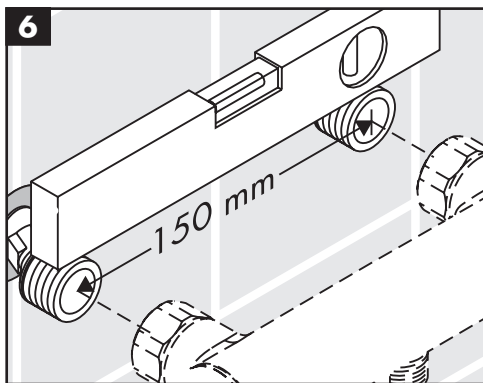
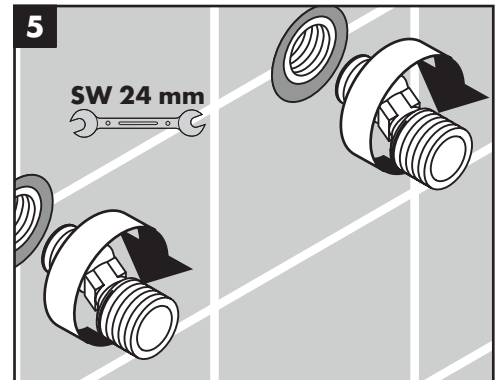
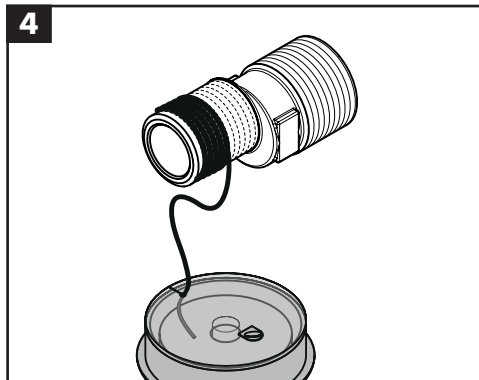
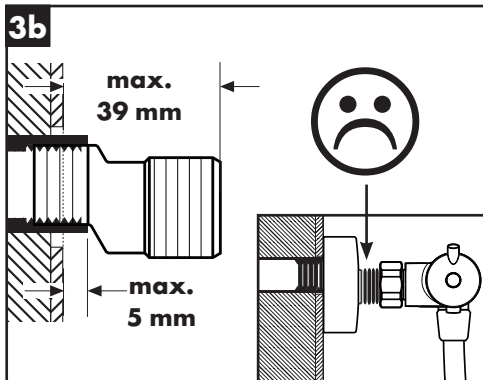
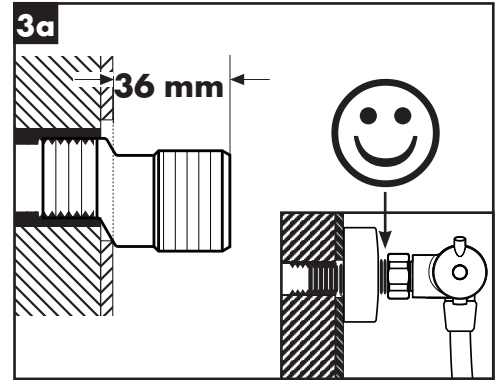
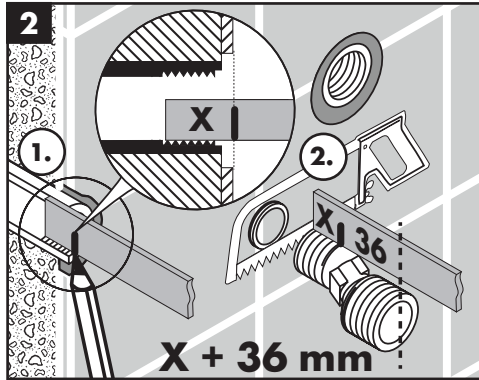
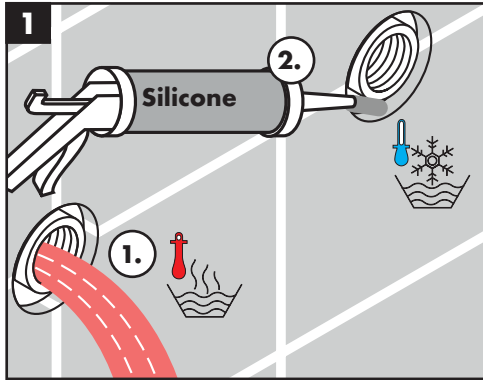

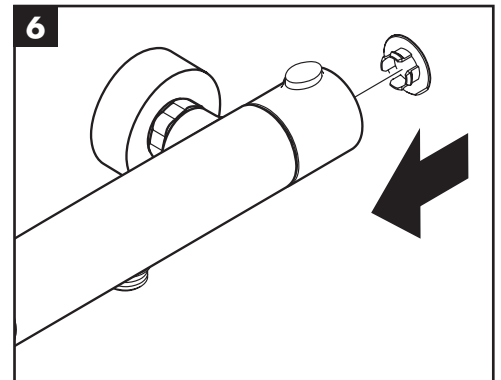
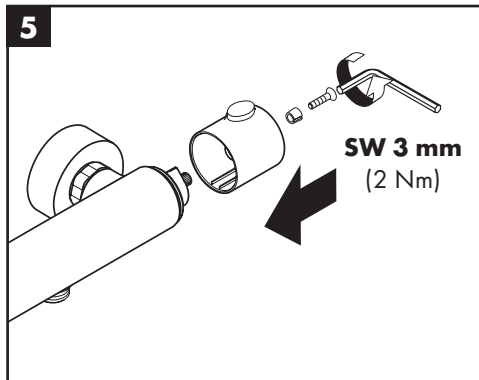
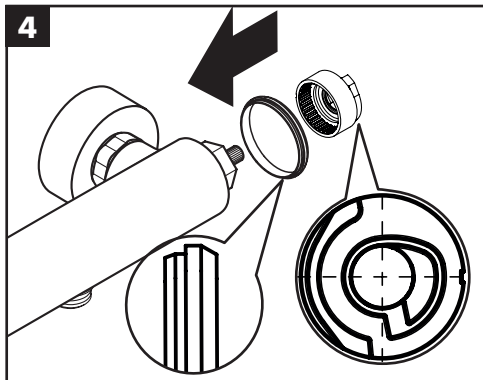
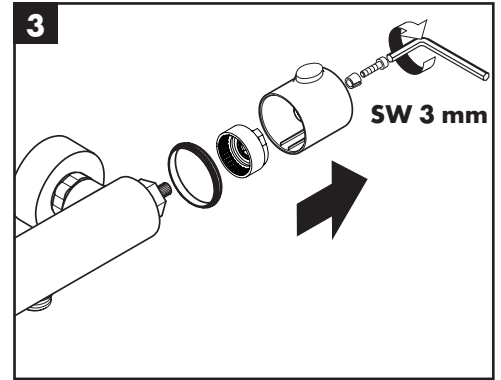
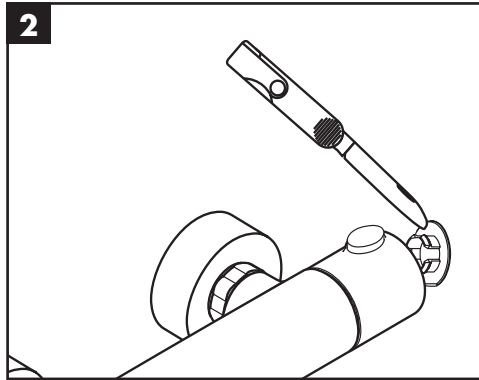
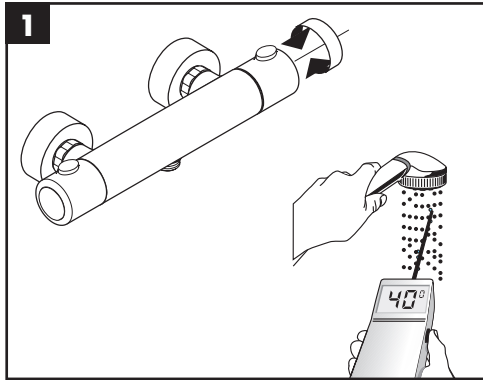

max.
≈ 42° C

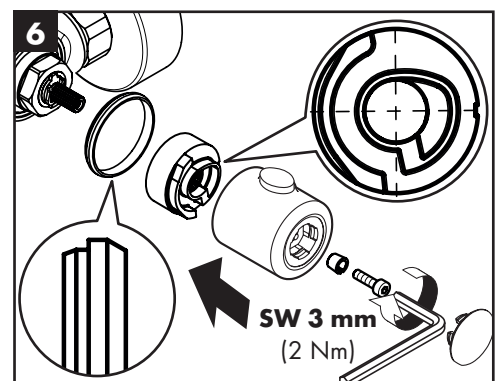
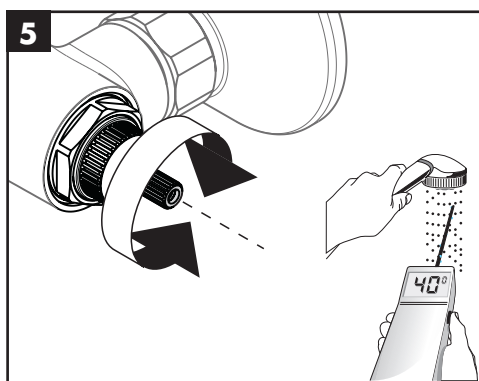
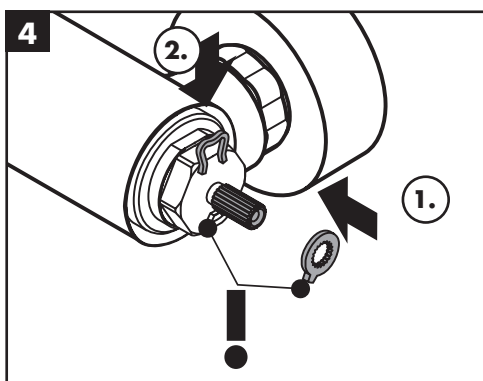
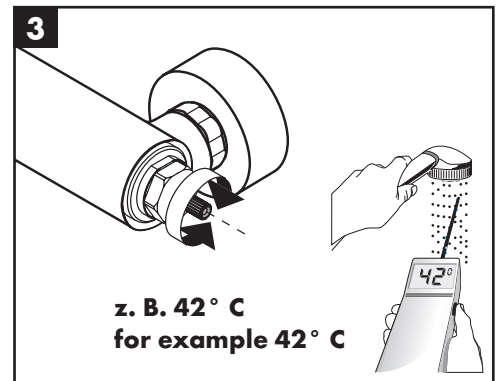
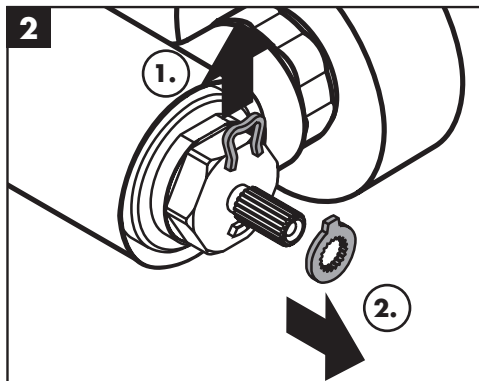
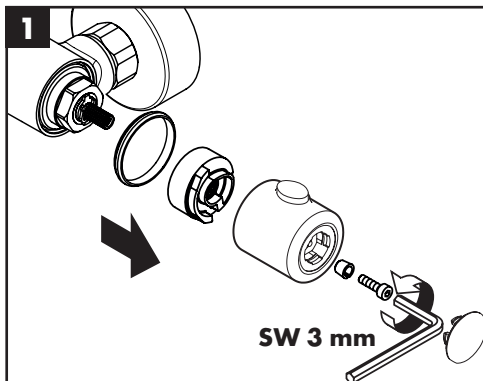

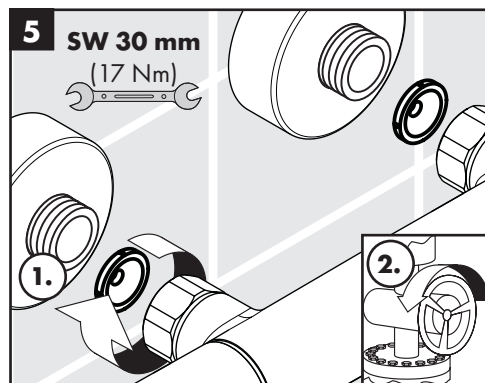
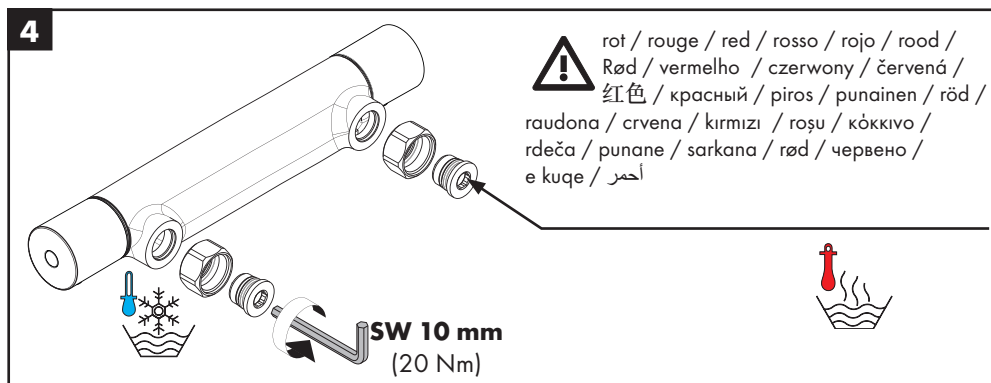
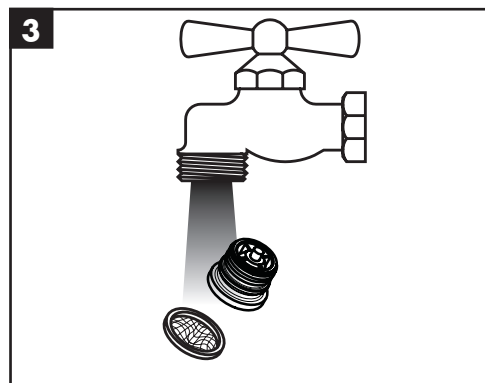
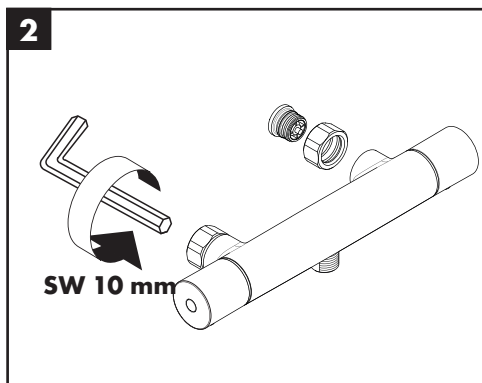
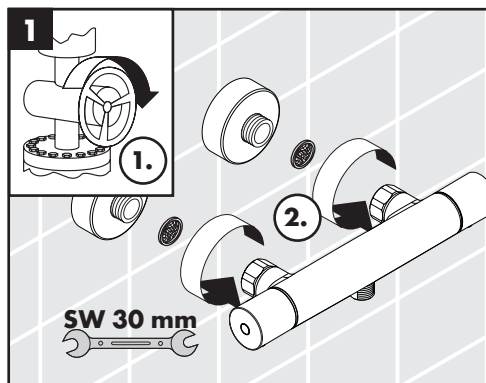
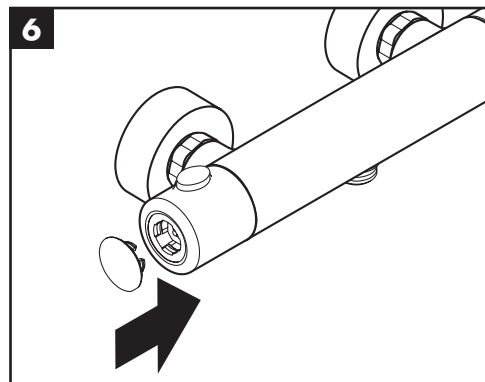
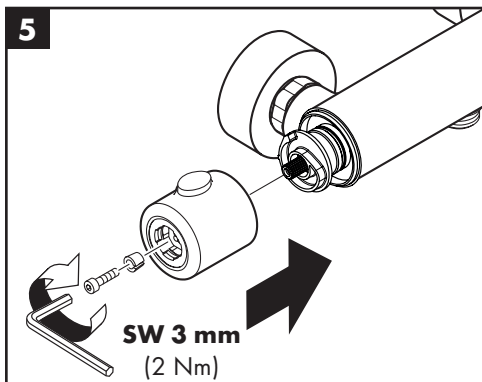
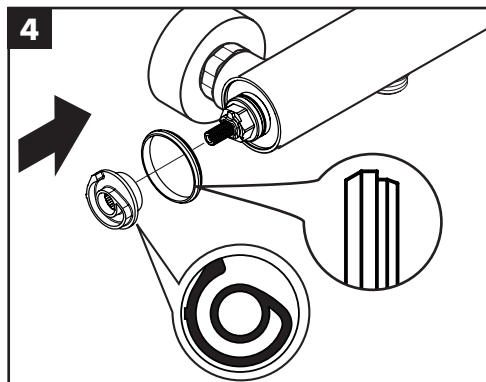
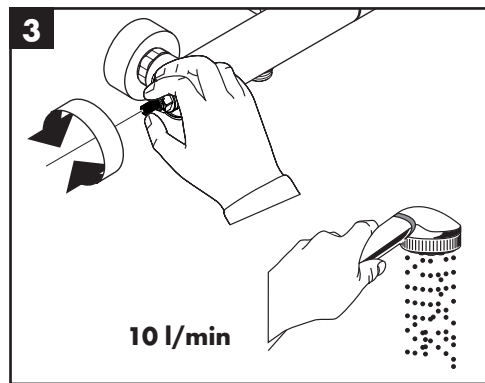
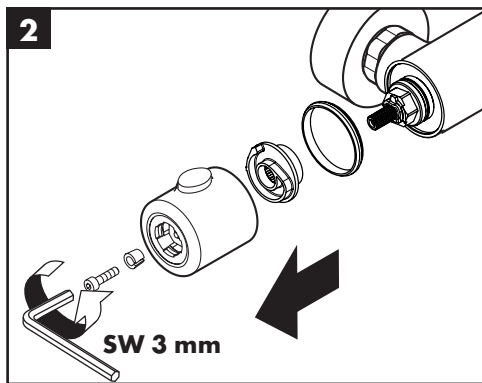
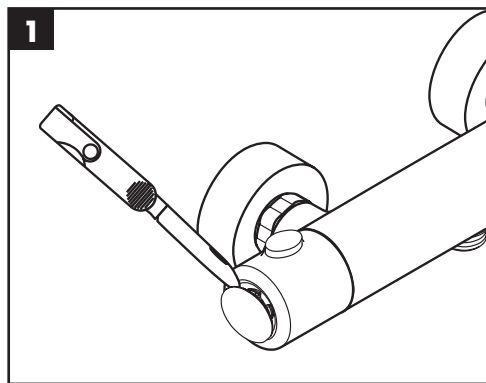

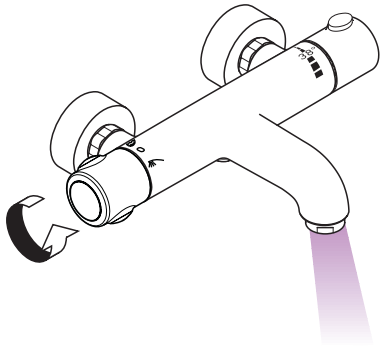

öffnen / ouvert / open / aperto / abierto / open / åbne / abrir / otworzyć / otevřít / otvorit / 开 / открыть / nyitás / avaaaminen / öppna / atidaryti / Otvoranje / açmak / deschide / ανοικτό / odpreti / avage / atvērt / otvoriti / åpne / отварање / hare / فتح

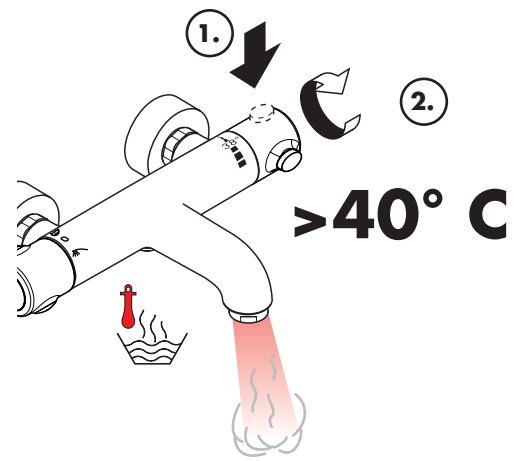
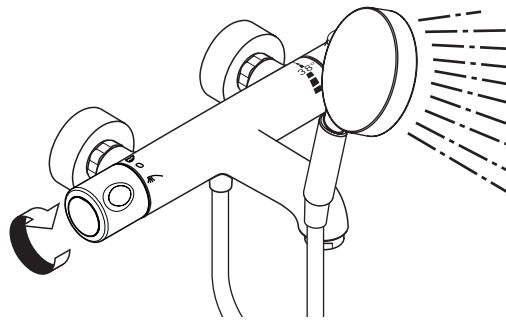

warm / chaud / hot / caldo / caliente / warm / varmt / quente / ciepła / teplá / teplá / 热 / горячая / meleg / lämmin / varmt / karštas / Vruća voda / sıcak / cald / ζεστό / toplo / kuum / karsts / topla / varm / тепло / i ngrohtë / ساخن

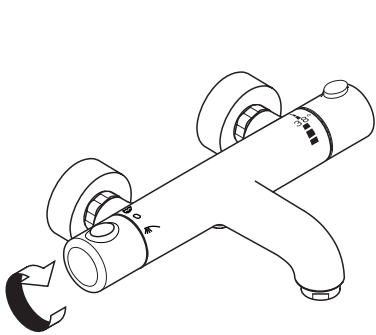

schließen / fermé / close / chiudere / cerrar / sluiten / lukke / fechar / zamknąć / zavřít / uzavrieť / 关 / закрыть / bezárás / sulkeminen / stänga / uždaryti / Zatvaranje / kapatmak / închide / κλειστό / zarpeti / sulgege / aizvērt / zatvori / lukke / затваряне / mbylle / إغلاق



kalt / froid / cold / freddo / frío / koud / koldt / fria / zimna / studená / studená / 冷 / холодная / hideg / kylmä / kallt / šaltas / Hladno / soğuk / reze / κρύο / mrzlo / külm / auksts / hladno / kaldt / студено / i ftohtë / بارد

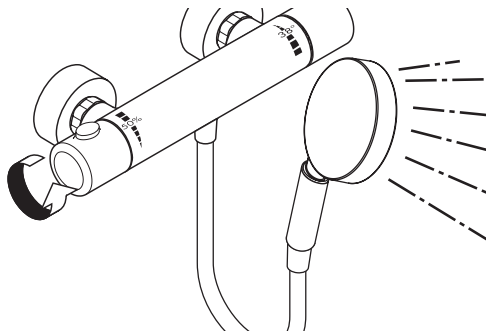

öffnen / ouvert / open / aperto / abierto / open / åbne / abrir / otworzyć / otevřít / otvorit / 开 / открыть / nyitás / avaaaminen / öppna / atidaryti / Otvoranje / açmak / deschide / ανοικτό / odpreti / avage / atvērt / otvoriti / åpne / отварање / hare / فتح

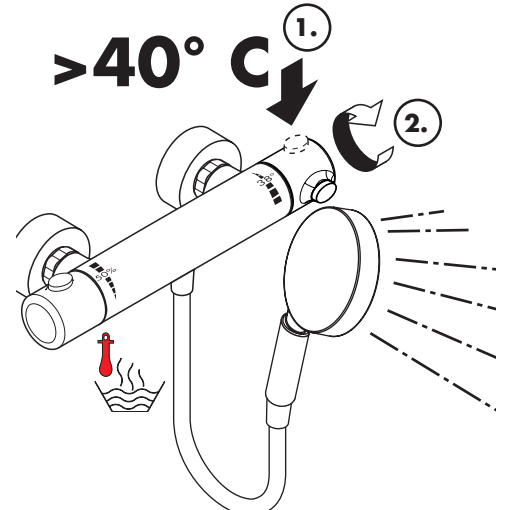
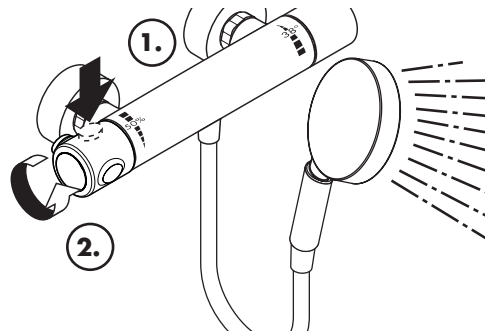

warm / chaud / hot / caldo / caliente / warm / varmt / quente / ciepła / teplá / teplá / 热 / горячая / meleg / lämmin / varmt / karštas / Vruća voda / sıcak / cald / ζεστό / toplo / kuum / karsts / topla / varm / тепло / i ngrohtë / ساخن

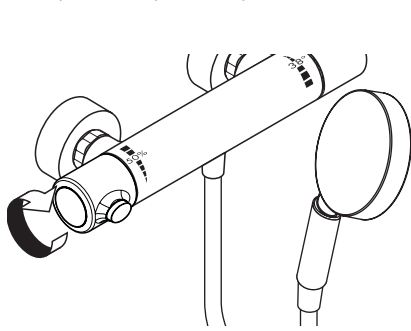

schließen / fermé / close / chiudere / cerrar / sluiten / lukke / fechar / zamknąć / zavřít / uzavrieť / 关 / закрыть / bezárás / sulkeminen / stänga / uždaryti / Zatvaranje / kapatmak / închide / κλειστό / zarpeti / sulgege / aizvērt / zatvori / lukke / затваряне / mbylle / إغلاق

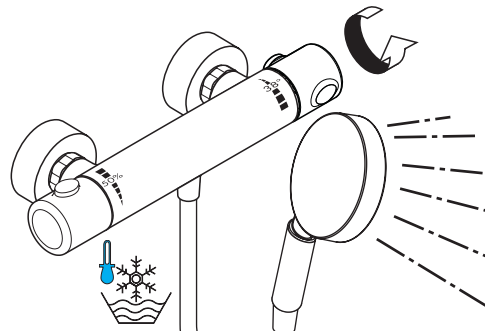

kalt / froid / cold / freddo / frío / koud / koldt / fria / zimna / studená / studená / 冷 / холодная / hideg / kylmä / kallt / šaltas / Hladno / soğuk / reze / κρύο / mrzlo / külm / auksts / hladno / kaldt / студено / i ftohtë / بارد



EcoStat 1001 SL

13241000

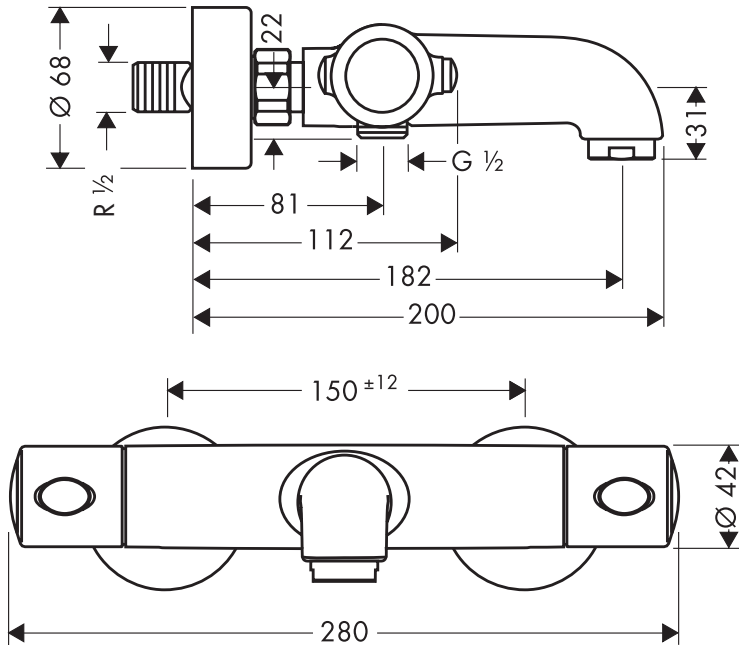

EcoStat 1001 SL

13261000

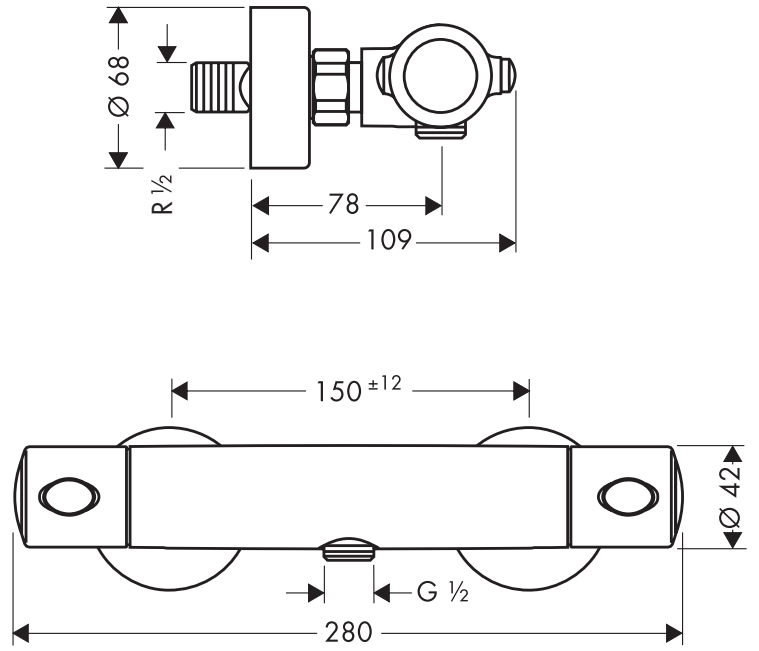

EcoStat 1001 SL

13241000

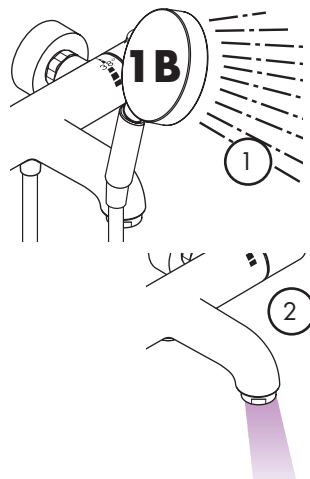
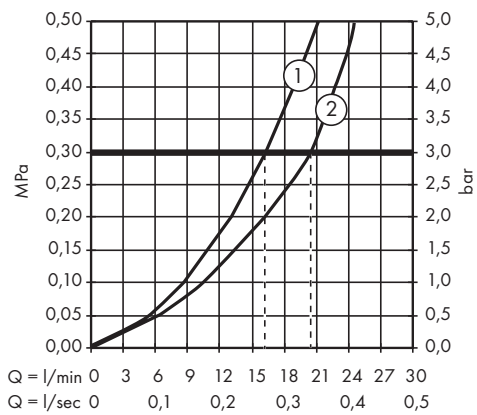

EcoStat 1001 SL

13261000

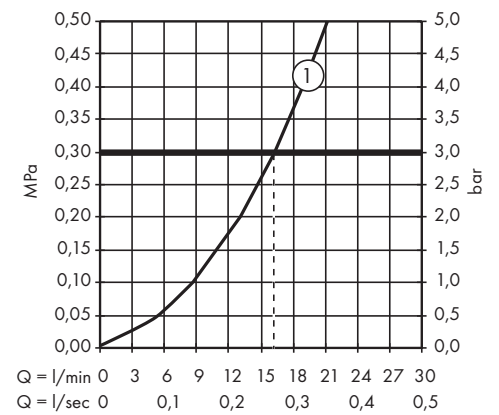



Ecostat 1001 SL

13241000

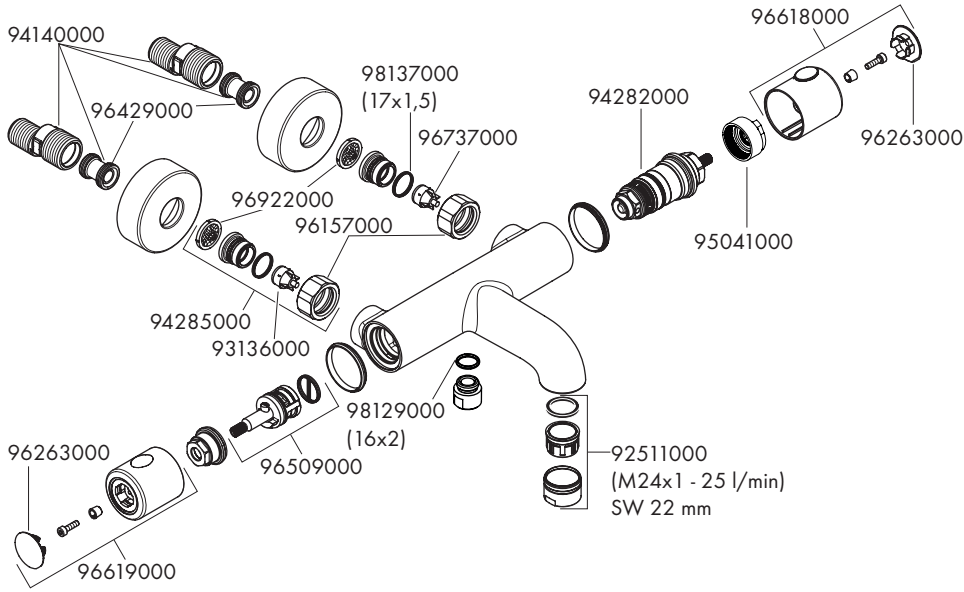

Ecostat 1001 SL

13261000

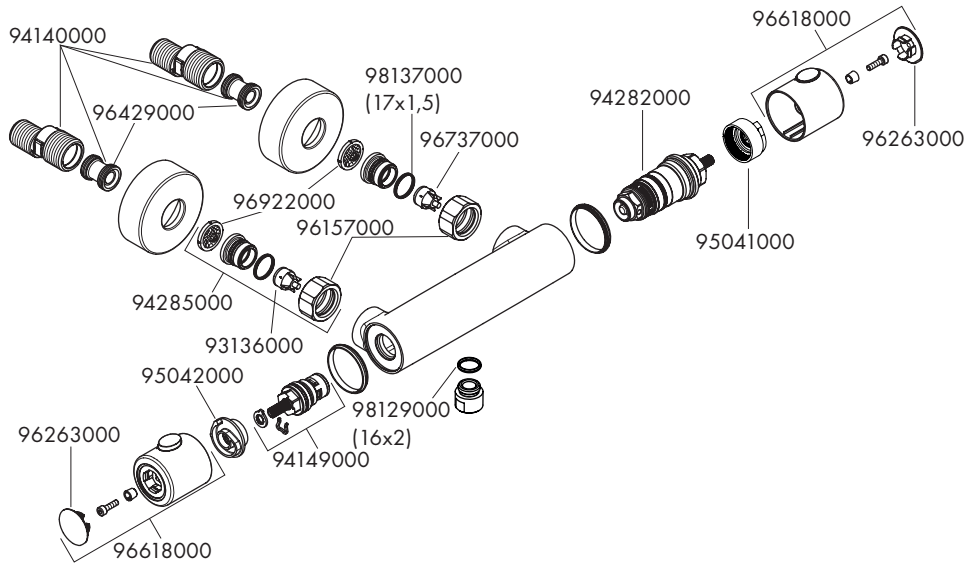

	P-IX	DVGW	SINTEF	NF	STF	CERTIFICATION BODY SE KIWA	ETA	GODKENDT TIL DRIKKEVAND
13241000	PA-IX 9374/IBB	CM0449			X		X	
13261000	PA-IX 9373/IB	CM0449			X		X	

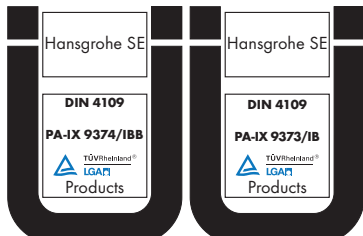



[www.hansgrohe.com/
cleaning-recommendation](http://www.hansgrohe.com/cleaning-recommendation)

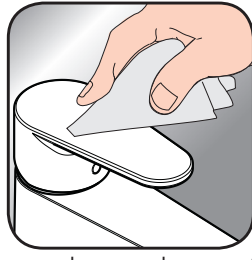

[www.hansgrohe.com/
cleaning-recommendation](http://www.hansgrohe.com/cleaning-recommendation)



[www.hansgrohe.com/
cleaning-recommendation](http://www.hansgrohe.com/cleaning-recommendation)



[www.hansgrohe.com/
cleaning-recommendation](http://www.hansgrohe.com/cleaning-recommendation)

- DE** Reinigungsempfehlung / Garantie / Kontakt
FR Recommandation pour le nettoyage / Garanties / Contact
EN Cleaning recommendation / Warranty / Contact
IT Raccomandazione di pulizia / Garanzia / Contatto
ES Recomendaciones para la limpieza / Garantía / Contacto
NL Aanbevelingen inzake reiniging / Garantie / Contact
DK Rensning, anbefaling / Garanti / Kontakt
PT Recomendações de limpeza / Garantia / Contacto
PL Zalecenie dotyczące pielęgnacji / Gwarancja / Kontakt
CS Doporučení k čištění / Záruka / Kontakt
SK Odporúčania pre čistenie / Záruka / Kontakt
ZH 清洁指南 / 担保 / 接触
RU Рекомендации по очистке / Гарантия / Контакты
HU Tisztítási tanácsok / Garancia / érintkezés
FI Puhdistussuositus / Takuu / Kosketus

- SV** Rengöringsrekommendationer / Garanti / Contacto
LT Valymo rekomendacijos / Garantija / Kontaktai
HR Preporuke za čišćenje / Garancija / Kontakt
TR Temizleme önerisi / Garanti / Temas
RO Recomandări pentru curățare / Garanție / Contact
EL Σύσταση καθαρισμού / Εγγύηση / επαφή
SL Priporočilo za čiščenje / Garancija / Kontakt
ET Puhastussuovitused / Garantii / Kontakt
LV Tīrīšanas ieteikumi / Garantija / Kontakti
SR Preporuke za čišćenje / Garancija / Kontakt
NO Anbefaling for rengjøring / Garanti / Kontakt
BG Препоръка за почистване / Гаранция / Контакт
SQ Këshilla rreth pastrimit / Garancia / Kontakt
KO 세정시 권장사항 / 품질보증 / 접촉
AR توصيات التنظيف / الضمان (الولايات المتحدة الأمريكية) / اتصال



Safety and Important Information

Hansgrohe products are safe provided they are installed, used and maintained in accordance with these instructions and recommendations.

Please read these instructions thoroughly and retain for future use.

The plumbing installation of this thermostat mixing valve must comply with the requirements of UK

Water Regulations/Bylaws (Scotland), Building Regulations or any other regulations specified by the local Water Authority and supplier.

The installation of thermostatic mixing valves must comply with the requirements of the Water Supply (Water Fittings) Regulations 1999.

We strongly recommend that you use a plumber registered with or a member of an Association:

Chartered Institute of Plumbing and Heating Engineering (CIPHE)

Water Industry Approved Plumber Scheme (WIAPS)

Dispose of plastic bags carefully

Keep children well away from the work area.

Check for hidden pipes and cables in the wall before drilling holes.

The unit must be mounted on a finished waterproofed wall surface (usually tiles).

If you are using power tools (e.g. to drill holes) wear safety glasses and always disconnect tools from the power supply after use.

Do not operate the shower unit if the hand shower or spray hose has been damaged or is blocked.

Do not block the flow of water from the hand shower, by placing it on your hand or any other part of your body or foreign object.

The valve must remain accessible to maintain and commission it.

The thermostatic unit should be serviced annually by a qualified person to ensure maximum safety during use.

The thermostatic mixing valve will be installed in such a position that maintenance of the TMV and its valves and the commissioning and testing of the TMV can be undertaken.

The mixer is fitted with check valves (page 36 pos. 96737000 and 93136000). There are filters on the thermostatic element too (page 36 pos. 96922000 and 94282000).

The fitting of isolation valves is required (preferred location page 39 Installation Requirements)

Technical Hotline (for UK only)

Tel: 01372465655

Email: Technical@hansgrohe.co.uk

(Diese Servicehotline ist nur für das Vereinigte Königreich Großbritannien, nicht z. B. für Deutschland)

Technical Data

This thermostatic valve will suit supplies of:

HIGH PRESSURE (HP-S)

Operating pressure: max. 10 bar

Recommended operating pressure: 1 - 5 bar

Test pressure: 16 bar

Hot water temperature: max. 70 °C

Recommended hot water temp.: 65 °C

Rate of flow from bath spout: 20 l/min. @ 3 bar

Rate of flow from shower outlet: 18 l/min. @ 3 bar

Maximum outlet temperature: 43 °C +/-*

Safety check: 40 °C

Hot water connection: Left hand

Cold water connection: Right hand

Minimum difference between hot

water and mixed water temperature: 6 K

Hot and cold supply pressure should be balanced

Mixed water temperature

Application Mixed water temperature

Shower (at point of discharge). 41 °C max.

Washbasin 41 °C max.

Bath (44 °C fill) 44 °C max.

Bath (46 °C fill) 46 °C max.

* For preset outlet temperature adjustment - See page 32.

NB. If a water supply is fed by gravity then the supply pressure should be verified to ensure the conditions of use are appropriate for the valve. Valves operating

outside of these supply conditions cannot be guaranteed to operate as a TMV2 or TMV3 valve.

Recommended outlet temperatures

The BuildCert TMV scheme recommends the following set maximum mixed water outlet temperatures for use in all premises:

44 °C for bath fill but see notes below;

41 °C for showers;

41 °C for washbasins.

The mixed water temperatures must never exceed 46 °C.

The maximum mixed water temperature can be 2 °C above the recommended maximum set outlet temperatures.

Note: 46 °C is the maximum mixed water temperature from the bath tap. The maximum temperature takes account of the allowable temperature tolerances inherent in thermostatic mixing valves and temperature losses in metal baths.

It is not a safe bathing temperature for adults or children.

The British Burns Association recommends 37 to 37.5 °C as a comfortable bathing temperature for children. In premises covered by the Care Standards Act 2000, the maximum mixed water outlet temperature is 43 °C

Installation Requirements

This thermostatic mixer valve must be installed in compliance with current Water Regulations. If you have any doubts about the Water Regulation requirements contact your local water services provider or use the services of a professional plumber.

This mixer valve is suitable for use with the following water supply systems:

Gas Combination Boiler (multi-point) 1.0 - 10 bar*

Unvented System (pressure balanced) 1.0 - 10 bar

Pumped System 1.0 - 10 bar

IMPORTANT: If you install this mixer with a gravity fed system, there must be a minimum head (vertical distance) from the underside of the cold water storage tank to the showerhead position of at least 5 metre.

Before connecting the mixer, water should be flushed through the system to remove all debris that might otherwise damage the valve.

* If pressure is in excess of 3.5 bar, a pressure-reducing valve should be fitted.

Supply Conditions TMV2

Operating pressure range	High pressure
Maximum static pressure - bar	10
Flow pressure, hot and cold - bar	0.5 to 5
Hot supply temperature - °C	55 to 65
Cold supply temperature - °C	5 to 25

Supply Conditions TMV3

Operating pressure range	High pressure
Maximum static pressure - bar	10
Flow pressure, hot and cold - bar	1 to 5
Hot supply temperature - °C	52 to 65
Cold supply temperature - °C	5 to 20

Commissioning and in-service tests

Commissioning

Purpose

Since the installed supply conditions are likely to be different from those applied in the laboratory tests it is appropriate, at commissioning, to carry out some simple checks and tests on each mixing valve to provide a performance reference point for future in-service tests.

Procedure

- Check that:
 - the designation of the thermostatic mixing valve matches the intended application
 - the supply pressures are within the range of operating pressures for the designation of the valve
 - the supply temperatures are within the range permitted for the valve and by guidance information on the prevention of legionella etc.
- Adjust the temperature of the mixed water in accordance with the manufacturer's instructions (page 32) and the requirement of the application and then carry out the following sequence:
 - record the temperature of the hot and cold water supplies
 - record the temperature of the mixed water at the largest draw-off flow rate

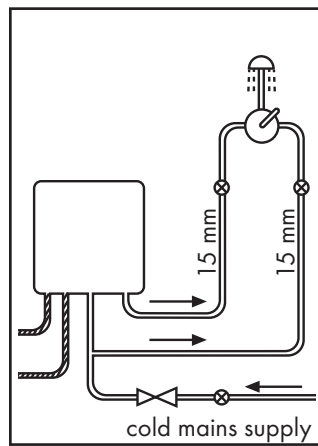
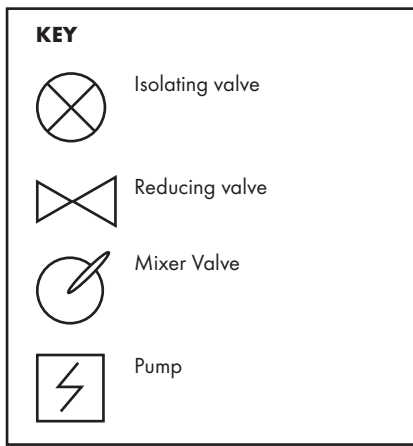

Gas Combination Boiler
(multi-point)

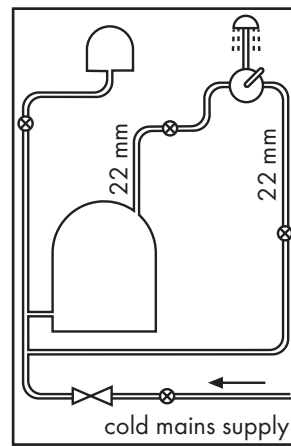

Unvented System
(pressure balanced)

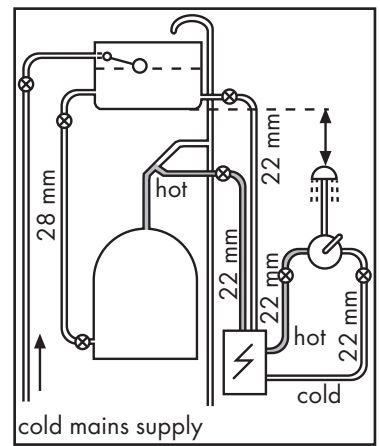

Pumped System

- record the temperature of the mixed water at a smaller draw-off flow rate, which shall be measured
- isolate the cold water supply to the mixing valve and monitor the mixed water temperature
- record the maximum temperature achieved as a result of (d) and the final stabilised temperature

NOTE: The final stabilised mixed water temperature should not exceed the values in Table A.

- record the equipment, thermometer etc. used for the measurements

Table A: Guide to maximum stabilised temperatures recorded during site tests

Application	Mixed water temperature
Shower	43 °C
Washbasin	43 °C
Bath (44 °C fill)	46 °C
Bath (46 °C fill)	48 °C

The mixed water temperature at terminal fitting should never exceed 46°C.

If there is a residual flow during the commissioning or the annual verification (cold water supply isolation test), then this is acceptable providing the temperature of the water seeping from the valve is no more than 2 °C above the designated maximum mixed water outlet temperature setting of the valve.

Temperature readings should be taken at the normal flow rate after allowing for the system to stabilise.

The sensing part of the thermometer probe must be fully submerged in the water that is to be tested.

Any TMV that has been adjusted or serviced must be re-commissioned and re-tested in accordance with the manufacturers' instructions.

In-service tests

Purpose

The purpose of in-service tests is to regularly monitor and record the performance of the thermostatic mixing valve. Deterioration in performance can indicate the need for service work on the valve and/ or the water supplies.

Procedure

- Carry out the procedure **2.** (a) to (e) on page 38 using the same measuring equipment, or equipment to the same specifications.
- If the mixed water temperature has changed significantly from the previous test results (e.g. > 1 K), record the change and before re-adjusting the mixed water temperature check:
 - that any in-line or integral strainers are clean
 - any in-line or integral check valves or other anti-backsiphonage devices are in good working order
 - any isolating valves are fully open
- With an acceptable mixed water temperature, complete the procedure **2.** (a) to (e) on page 38.
- If at step **2.** (e) on page 38 the final mixed water temperature is greater than the values in Table A and / or the maximum temperature exceeds the corresponding value from the previous test results by more than about 2 K, the need for service work is indicated.

NOTE: In-service tests should be carried out with a frequency which identifies a need for service work before an unsafe water temperature can result. In the absence of any other instruction or guidance, the procedure described in „Frequency of in-service tests“ may be used.

Frequency of in-service tests TMV3*

General

In the absence of any other instruction or guidance on the means of determining the appropriate frequency of in-service testing, the following procedure may be used:

- 6 to 8 weeks after commissioning carry out the tests given in **2.** on page 38.
- 12 to 15 weeks after commissioning carry out the tests given in **2.** on page 38.
- Depending on the results of **1.** and **4.** several possibilities exist:
 - If no significant changes (e.g. < 1 K) in mixed water temperatures are recorded between commissioning and **1.**, or between commissioning and **4.** the next in-service test can be deferred to 24 to 28 weeks after commissioning.
 - If small changes (e.g. 1 to 2 K) in mixed water temperatures are recorded in only one of these periods, necessitating adjustment of the mixed water temperature, then the next in-service test can be deferred to 24 to 28 weeks after commissioning.
 - If small changes (e.g. 1 to 2 K) in mixed water temperatures are recorded in both of these periods, necessitating adjustment of the mixed water temperature, then the next in-service test should be carried out at 18 to 21 weeks after commissioning.
 - If significant changes (e.g. > 2 K) in mixed water temperatures are recorded in either of these periods, necessitating service work, then the next in-service test should be carried out at 18 to 21 weeks after commissioning.
- The general principle to be observed after the first 2 or 3 in-service tests is that the intervals of future tests should be set to those which previous tests have shown can be achieved with no more than a small change in mixed water temperature.

***TMV2:** The frequency of performing the in-service tests is 1 year maximum.

Thermostatic Adjustment

Temperature Limitation

The temperature is limited by the safety stop to 40 °C. If a higher temperature is required, it is possible to over ride the safety stop by depressing the safety button.

NB. It is recommended that for private domestic use the maximum mixed water temperature be set at the following factory set values:

Shower Mixer 43 °C

Bath/Shower 43 °C

Temperatures can be set by following the procedures on page 32. This ensures that after correct installation the outlet temperature of the water can never exceed 43 °C.

To guarantee a smooth running of the thermostatic element, it is necessary from time to time to turn the thermostat from total hot to total cold. The thermostatic mixer valve should be checked annually by a qualified person to ensure correct operation.

The mixer is fitted with check valves (page 36 pos. 96737000 and 93136000) and filters (page 36 pos 96922000 and 94282000). If the water flow drops the filters need to be cleaned. For that purpose please follow the steps 1 - 5 on page 33.

Calibrating Thermostat

If the temperature reading is different to the showering temperature, follow the steps 1 - 6 on page 32.

hansgrohe

Hansgrohe · Auestraße 5 - 9 · D-77761 Schiltach · Telefon +49 (0) 78 36/51-1282 · Telefax +49 (0) 7836/511440
E-Mail: info@hansgrohe.com · Internet: www.hansgrohe.com

09/2019
9.09477.09