

## PROHLÁŠENÍ O VLASTNOSTECH

### DoP 0342

pro pro vstříkovací systém fischer FIS VL (Kovové kotvy do betonu)

CS

1. Jedinečný identifikační kód typu výrobku: DoP 0342
2. Zamýšlené/zamýšlená použití: **Dodatečné upevnění v tažené a tlačené zóně betonu, viz. dodatek, obzvláště Přílohy B1 - B9.**
3. Výrobce: **fischerwerke GmbH & Co. KG, Otto-Hahn-Straße 15, 79211 Denzlingen, Německo**
4. Zplnomocněný zástupce: -
5. Systém/systémy POSV: 1
6. Evropský dokument pro posuzování: **EAD 330499-01-0601, Edition 04/2020**  
Evropské technické posouzení: **ETA-10/0352; 2023-07-26**  
Subjekt pro technické posuzování: **DIBt- Deutsches Institut für Bautechnik**  
Oznámený subjekt/oznámené subjekty: **2873 TU Darmstadt**
7. Deklarovaná vlastnost/Deklarované vlastnosti:  
**Mechanická odolnost a stabilita (BWR 1)**  
**Charakteristická únosnost v tahu (pro statickou a kvazistatickou akci):**  
Odolnost proti selhání oceli: Přílohy C1 - C3  
Odolnost proti kombinovanému porušení vytažením a selháním betonu: Přílohy C4 - C6  
Odolnost proti selhání betonu: Příloha C4  
Okrajová vzdálenost bránící rozštěpení při zatížení: Příloha C4  
Pevnost: Přílohy C4 - C6  
Maximální utahovací moment při instalaci: Přílohy B3, B4  
Minimální vzdálenost od okraje a rozteč: Přílohy B3 - B5  
**Charakteristická únosnost ve smyku (pro statickou a kvazistatickou akci):**  
Odolnost proti selhání oceli: Přílohy C1 - C3  
Odolnost proti selhání rozštěpením: Příloha C4  
Odolnost proti selhání okraje betonu: Příloha C4  
**posuny při krátkodobém a dlouhodobém zatížení:**  
Posuny při krátkodobém a dlouhodobém zatížení: Přílohy C7, C8  
**Charakteristická únosnost a posuny pro seismické kategorie C1 a C2:**  
Odolnost proti tahovému zatížení, posuny, kategorie C1: NPĐ  
Odolnost proti tahovému zatížení, posuny, kategorie C2: NPĐ  
Odolnost proti smykovému zatížení, posuny, kategorie C1: NPĐ  
Odolnost proti smykovému zatížení, posuny, kategorie C2: NPĐ  
Koeficient prstencové mezery: NPĐ  
**Hygiena, zdraví a životní prostředí (BWR 3)**  
Obsah, emise a / nebo uvolňování nebezpečných látek: NPĐ
8. Příslušná technická dokumentace a/nebo specifická technická dokumentace: -

Vlastnosti výše uvedeného výrobku jsou ve shodě se souborem deklarovaných vlastností. Toto prohlášení o vlastnostech se v souladu s nařízením (EU) č. 305/2011 vydává na výhradní odpovědnost výrobce uvedeného výše.

Podepsáno za výrobce a jeho jménem:



Dr.-Ing. Oliver Geibig, Výkonný ředitel pro obchodní jednotky a inženýrství  
Tumlingen, 2023-08-15



Jürgen Grün, Výkonný ředitel pro chemii a kvalitu

Toto PoV bylo připraveno v různých jazykových mutacích. V případě rozporu vždy rozhoduje interpretace verze v anglickém jazyce.

Příloha obsahuje nepovinné a doplňkové informace v anglickém jazyce nad rámec zákonných požadavků.

Translation guidance Essential Characteristics and Performance Parameters for Annexes

**Pokyny pro překlad Základní charakteristiky a výkonnostní parametry příloh**

Mechanical resistance and stability (BWR 1)		
Mechanická odolnost a stabilita (BWR 1)		
Characteristic resistance to tension load (static and quasi-static loading):		
<b>Charakteristická únosnost v tahu (pro statickou a kvazistatickou akci):</b>		
1	Resistance to steel failure: <b>Odolnost proti selhání oceli:</b>	$N_{Rk,s}$ [kN]
2	Resistance to combined pull-out and concrete cone failure: <b>Odolnost proti kombinovanému porušení vytažením a selháním betonu:</b>	$T_{Rk}$ and/or $T_{Rk,100}$ [N/mm <sup>2</sup> ], $\psi_{sus}^0$ [-] (BF) $N_{Rk,p}$ and/or $N_{Rk,p,100}$ [kN] (BEF)
3	Resistance to concrete cone failure: <b>Odolnost proti selhání betonu:</b>	$c_{cr,N}$ [mm], $k_{cr,N}$ , $k_{ucr,N}$ [-]
4	Edge distance to prevent splitting under load: <b>Okrajová vzdálenost bránící rozštěpení při zatížení:</b>	$c_{cr,sp}$ [mm]
5	Robustness: <b>Pevnost:</b>	$V_{inst}$ [-]
6	Maximum installation torque: <b>Maximální utahovací moment při instalaci:</b>	max $T_{inst}$ [Nm] (BF)
	Installation torque: <b>Utahovací moment při instalaci:</b>	$T_{inst}$ [Nm] (BEF)
7	Minimum edge distance and spacing: <b>Minimální vzdálenost od okraje a rozteč:</b>	$c_{min}$ , $s_{min}$ , $h_{min}$ [mm]
Characteristic resistance to shear load (static and quasi-static loading):		
<b>Charakteristická únosnost ve smyku (pro statickou a kvazistatickou akci):</b>		
8	Resistance to steel failure: <b>Odolnost proti selhání oceli:</b>	$V_{Rk,s}^0$ [kN], $M_{Rk,s}^0$ [Nm], $k_7$ [-]
9	Resistance to pry-out failure: <b>Odolnost proti selhání rozštěpením:</b>	$k_8$ [-]
10	Resistance to concrete edge failure: <b>Odolnost proti selhání okraje betonu:</b>	$d_{nom}$ , $l_f$ [mm]
Displacements under short-term and long-term loading:		
<b>posuny při krátkodobém a dlouhodobém zatížení:</b>		
11	Displacements under short-term and long-term loading: <b>Posuny při krátkodobém a dlouhodobém zatížení:</b>	$\delta_0$ , $\delta_\infty$ [mm or mm/(N/mm <sup>2</sup> )]
Characteristic resistance and displacements for seismic performance categories C1 and C2:		
<b>Charakteristická únosnost a posuny pro seismické kategorie C1 a C2:</b>		
12	Resistance to tension load, displacements:	
	<b>Odolnost proti tahovému zatížení, posuny, kategorie C1:</b>	C1 $N_{Rk,s,C1}$ [kN] (all) $T_{Rk,C1}$ [N/mm <sup>2</sup> ] (BF) $N_{Rk,p,C1}$ [kN] (BEF)
	<b>Odolnost proti tahovému zatížení, posuny, kategorie C2:</b>	C2 $N_{Rk,s,C2}$ [kN] (all) $T_{Rk,C2}$ [N/mm <sup>2</sup> ] (BF) $N_{Rk,p,C2}$ [kN] (BEF) $\delta_{N,C2}$ [mm] (all)
13	Resistance to shear load, displacements:	
	<b>Odolnost proti smykovému zatížení, posuny, kategorie C1:</b>	C1 $V_{Rk,s,C1}$ [kN] (all)
	<b>Odolnost proti smykovému zatížení, posuny, kategorie C2:</b>	C2 $V_{Rk,s,C2}$ [kN] (all) $\delta_{V,C2}$ [mm] (all)
14	Factor annular gap: <b>Koeficient prstencové mezery:</b>	$\alpha_{gap}$ [-]
Hygiene, health and the environment (BWR 3)		
<b>Hygiena, zdraví a životní prostředí (BWR 3)</b>		
15	Content, emission and/or release of dangerous substances: <b>Obsah, emise a / nebo uvolňování nebezpečných látek:</b>	-

## Specific Part

### 1 Technical description of the product

The "fischer injection system FIS VL" is a bonded fastener consisting of a cartridge with injection mortar fischer FIS VL, fischer FIS VL High Speed or fischer FIS VL Low Speed and a steel element according to Annex A4.

The steel element is placed into a drilled hole filled with injection mortar and is anchored via the bond between metal part, injection mortar and concrete.

The product description is given in Annex A.

### 2 Specification of the intended use in accordance with the applicable European Assessment Document

The performances given in Section 3 are only valid if the anchor is used in compliance with the specifications and conditions given in Annex B.

The verifications and assessment methods on which this European Technical Assessment is based lead to the assumption of a working life of the anchor of at least 50 years. The indications given on the working life cannot be interpreted as a guarantee given by the producer, but are to be regarded only as a means for choosing the right products in relation to the expected economically reasonable working life of the works.

### 3 Performance of the product and references to the methods used for its assessment

#### 3.1 Mechanical resistance and stability (BWR 1)

Essential characteristic	Performance
Characteristic resistance to tension load (static and quasi-static loading)	See Annex B 3 to B 5, C 1 to C 6
Characteristic resistance to shear load (static and quasi-static loading)	See Annex C 1 to C 4
Displacements under short-term and long-term loading	See Annex C 7 and C 8
Characteristic resistance and displacements for seismic performance categories C1 and C2	No performance assessed

#### 3.2 Hygiene, health and the environment (BWR 3)

Essential characteristic	Performance
Content, emission and/or release of dangerous substances	No performance assessed

**4 Assessment and verification of constancy of performance (AVCP) system applied, with reference to its legal base**

In accordance with the European Assessment Document EAD 330499-01-0601 the applicable European legal act is: [96/582/EC].

The system to be applied is: 1

# Installation conditions part 1

## fischer anchor rod FIS A / RG and standard threaded rod

### Pre-positioned installation

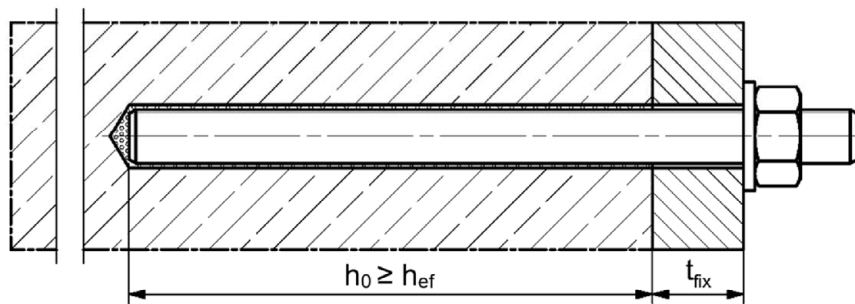

### Push through installation (annular gap filled with mortar)

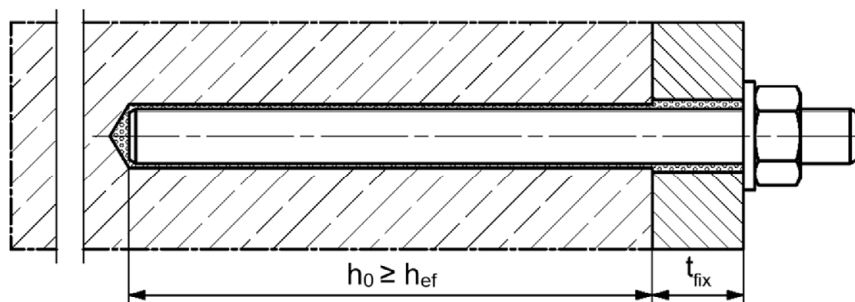

### Pre-positioned or push through installation with subsequently injected fischer filling disc (annular gap filled with mortar)

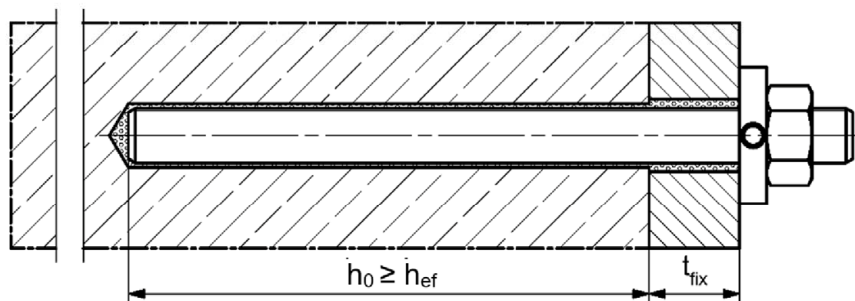

Figures not to scale

$h_0$  = drill hole depth

$h_{ef}$  = effective embedment depth

$t_{fix}$  = thickness of fixture

fischer injection system FIS VL

**Product description**  
Installation conditions part 1

**Annex A 1**  
Appendix 3/ 24

## Installation conditions part 2

### fischer internal threaded anchor RG M I

#### Pre-positioned installation

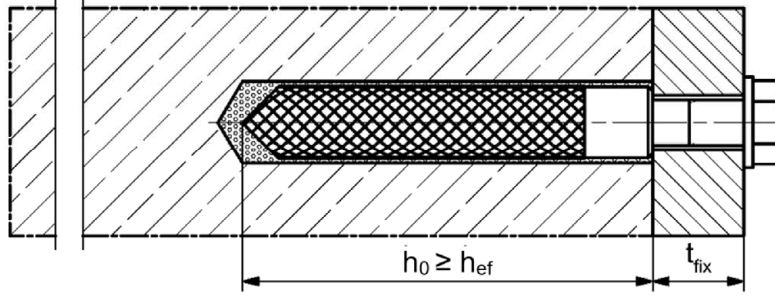

#### Pre-positioned installation with subsequently injected fischer filling disc (annular gap filled with mortar)

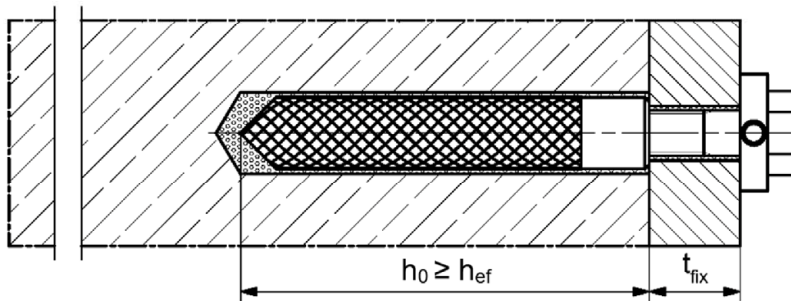

#### Reinforcing bar

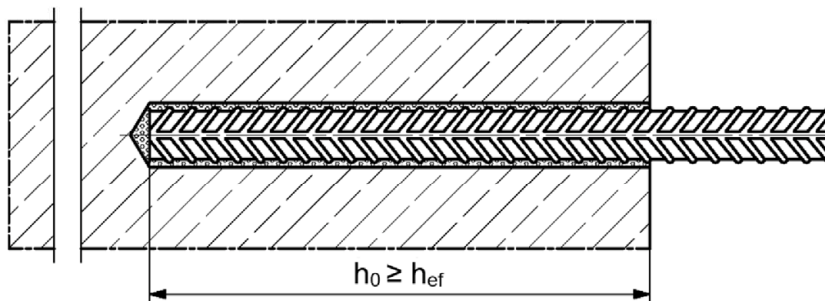

Figures not to scale

$h_0$  = drill hole depth

$h_{ef}$  = effective embedment depth

$t_{fix}$  = thickness of fixture

fischer injection system FIS VL

**Product description**  
Installation conditions part 2

**Annex A 2**  
Appendix 4/ 24

# Overview system components part 1

## Injection cartridge (shuttle cartridge) with sealing cap; Sizes: 360 ml, 825 ml

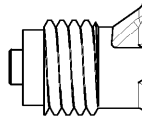
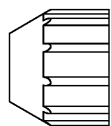

**Imprint:** FIS VL, FIS VL Low Speed or FIS VL High Speed, processing notes, shelf-life, piston travel scale (optional), curing times and processing times (depending on temperature), hazard code, size, volume/weight



## Injection cartridge (coaxial cartridge) with sealing cap; Sizes: 100 ml, 150 ml, 300 ml, 380 ml, 400 ml, 410 ml

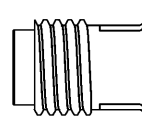
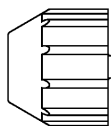

**Imprint:** FIS VL, FIS VL Low Speed or FIS VL High Speed, processing notes, shelf-life, piston travel scale (optional), curing times and processing times (depending on temperature), hazard code, size, volume/weight



## Static mixer FIS MR Plus for injection cartridges up to 410 ml

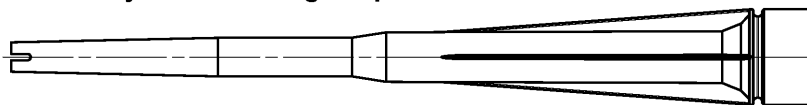

## Static mixer FIS JMR for injection cartridges with 825 ml

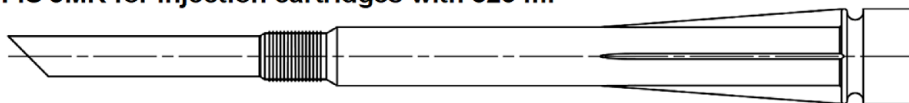

## Injection adapter and extension tube Ø 9 for static mixer FIS MR Plus; Injection adapter and extension tube Ø 9 or Ø 15 for static mixer FIS JMR

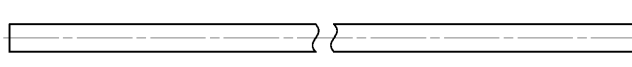
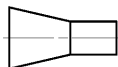

## Cleaning brush BS



## Blow-out pump AB G



## Compressed-air cleaning tool ABP



Figures not to scale

fischer injection system FIS VL

**Product description**  
Overview system components part 1;  
cartridges / static mixer / accessories

**Annex A 3**  
Appendix 5/ 24

## Overview system components part 2

### fischer anchor rod

Size: M6, M8, M10, M12, M16, M20, M24, M27, M30

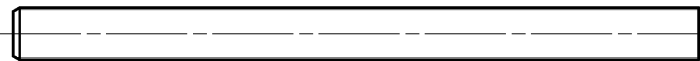

### fischer internal threaded anchor RG M I

Size: M8, M10, M12, M16, M20



### Screw / threaded rod / washer / hexagon nut

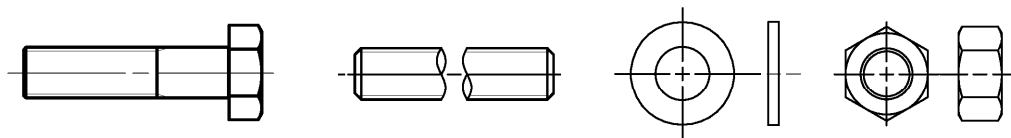

### fischer filling disc with injection adapter

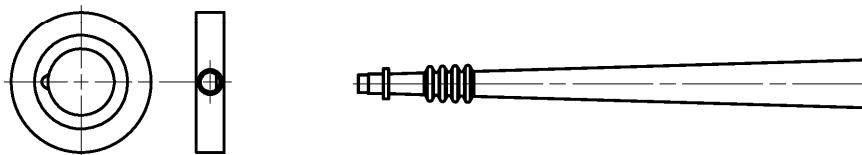

### Reinforcing bar

Nominal diameter:  $\phi 8$ ,  $\phi 10$ ,  $\phi 12$ ,  $\phi 14$ ,  $\phi 16$ ,  $\phi 20$



Figures not to scale

fischer injection system FIS VL

#### Product description

Overview system components part 2;  
metal parts, injection adapter

**Annex A 4**  
Appendix 6/ 24



**Table A5.1: Materials**





Part	Designation	Material		
1	Injection cartridge	Mortar, hardener, filler		
	Steel grade	Steel zinc plated	Stainless steel R acc. to EN 10088-1:2014 Corrosion resistance class CRC III acc. to EN 1993-1-4: 2006+A1:2015	High corrosion resistant steel HCR acc. to EN 10088-1:2014 Corrosion resistance class CRC V acc. to EN 1993-1-4: 2006+A1:2015
2	Anchor rod	Property class 4.8, 5.8 or 8.8; EN ISO 898-1:2013 electroplated $\geq 5 \mu\text{m}$ , EN ISO 4042:2018/Zn5/An(A2K) or hot dip galvanised $\geq 40 \mu\text{m}$ EN ISO 10684:2004+AC:2009 $f_{uk} \leq 1000 \text{ N/mm}^2$ $A_5 > 8\%$ fracture elongation	Property class 50, 70 or 80 EN ISO 3506-1:2020 1.4401; 1.4404; 1.4578; 1.4571; 1.4439; 1.4362; 1.4062, 1.4662, 1.4462; EN 10088-1:2014 $f_{uk} \leq 1000 \text{ N/mm}^2$ $A_5 > 8\%$ fracture elongation	Property class 50 or 80 EN ISO 3506-1:2020 or property class 70 with $f_{yk} = 560 \text{ N/mm}^2$ ; 1.4565; 1.4529; EN 10088-1:2014 $f_{uk} \leq 1000 \text{ N/mm}^2$ $A_5 > 8\%$ fracture elongation
3	Washer ISO 7089:2000	electroplated $\geq 5 \mu\text{m}$ , EN ISO 4042:2018/Zn5/An(A2K) or hot dip galvanised $\geq 40 \mu\text{m}$ EN ISO 10684:2004+AC:2009	1.4401; 1.4404; 1.4578; 1.4571; 1.4439; 1.4362; EN 10088-1:2014	1.4565; 1.4529; EN 10088-1:2014
4	Hexagon nut	Property class 4, 5 or 8 acc. EN ISO 898-2:2012 electroplated $\geq 5 \mu\text{m}$ , EN ISO 4042:2018/Zn5/An(A2K) or hot dip galvanised $\geq 40 \mu\text{m}$ EN ISO 10684:2004+AC:2009	Property class 50, 70 or 80 acc. EN ISO 3506-2:2020 1.4401; 1.4404; 1.4578; 1.4571; 1.4439; 1.4362; EN 10088-1:2014	Property class 50, 70 or 80 acc. EN ISO 3506-2:2020 1.4565; 1.4529 EN 10088-1:2014
5	fischer internal threaded anchor RG M I	Property class 5.8 ISO 898-1:2013 electroplated $\geq 5 \mu\text{m}$ , EN ISO 4042:2018/Zn5/An(A2K)	Property class 70 EN ISO 3506-1:2020; 1.4401; 1.4404; 1.4578; 1.4571; 1.4439; 1.4362; EN 10088-1:2014	Property class 70 EN ISO 3506-1:2020 1.4565; 1.4529; EN 10088-1:2014
6	Commercial standard screw or threaded rod for fischer internal threaded anchor RG M I	Property class 5.8 or 8.8; EN ISO 898-1:2013 electroplated $\geq 5 \mu\text{m}$ , EN ISO 4042:2018/Zn5/An(A2K) $A_5 > 8\%$ fracture elongation	Property class 70 EN ISO 3506-1:2020 1.4401; 1.4404; 1.4578; 1.4571; 1.4439; 1.4362; EN 10088-1:2014 $A_5 > 8\%$ fracture elongation	Property class 70 EN ISO 3506-1:2020 1.4565; 1.4529; EN 10088-1:2014 $A_5 > 8\%$ fracture elongation
7	fischer filling disc	electroplated $\geq 5 \mu\text{m}$ , EN ISO 4042:2018/Zn5/An(A2K) or hot dip galvanised $\geq 40 \mu\text{m}$ EN ISO 10684:2004+AC:2009	1.4401; 1.4404; 1.4578; 1.4571; 1.4439; 1.4362; EN 10088-1:2014	1.4565; 1.4529; EN 10088-1:2014
8	Reinforcing bar EN 1992-1- 1:2004 and AC:2010, Annex C	Bars and de-coiled rods, class B or C with $f_{yk}$ and $k$ according to NDP or NCI according to EN 1992-1-1:2004/NA $f_{uk} = f_{tk} = k \cdot f_{yk} (A_5 > 8\%)$		

--	--

fischer injection system FIS VL	<b>Annex A 5</b> Appendix 7/24
<b>Product description</b> Materials	

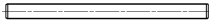
# Specifications of intended use part 1

**Table B1.1:** Overview use and performance categories

		FIS VL with ...					
		Anchor rod 	fischer internal threaded anchor RG M I 			Reinforcing bar 	
Hammer drilling with standard drill bit 		all sizes					
Hammer drilling with hollow drill bit 		Nominal drill bit diameter ( $d_0$ ) 12 mm to 35 mm					
Static and quasi static loading, in	uncracked concrete	all sizes	Tables: C1.1 C4.1	all sizes	Tables: C2.1 C4.1	all sizes	Tables: C3.1 C4.1
	cracked concrete	M8 to M20	C5.1 C7.1	- <sup>1)</sup>	C6.1 C7.2	$\phi$ 10 to $\phi$ 20	C6.2 C8.1
Seismic performance category	C1 C2	- <sup>1)</sup>					
Use category	I1 dry or wet concrete	all sizes					
	I2 water filled hole <sup>2)</sup>	M 12 to M 30	all sizes			- <sup>1)</sup>	
Installation direction	D3 (downward and horizontal and upwards (e.g. overhead))						
Installation temperature	$T_{i,min} = -10\text{ °C}$ to $T_{i,max} = +40\text{ °C}$ for the standard variation of temperature after installation						
Service temperature	Temperature range I	-40 °C to +80 °C	(max. short term temperature +80 °C; max. long term temperature +50 °C)				
	Temperature range II	-40 °C to +120 °C	(max. short term temperature +120 °C; max. long term temperature +72 °C)				

<sup>1)</sup> Performance not assessed

<sup>2)</sup> Valid for shuttle cartridges with 360 ml, 825 ml and coaxial cartridges with 380 ml, 400 ml, 410 ml

## Specifications of intended use part 2

### Base materials:

- Compacted reinforced or unreinforced normal weight concrete without fibres of strength classes C20/25 to C50/60 according to EN 206:2013+A1:2016

### Use conditions (Environmental conditions):

- Structures subject to dry internal conditions (zinc coated steel, stainless steel or high corrosion resistant steel).
- For all other conditions according to EN1993-1-4:2006+A1:2015 corresponding to corrosion resistance classes to Annex A 5 Table 5.1.

### Design:

- Fastenings are designed under the responsibility of an engineer experienced in fastenings and concrete work.
- Verifiable calculation notes and drawings are to be prepared taking account of the loads to be anchored. The position of the fastener is indicated on the design drawings (e. g. position of the fastener relative to reinforcement or to supports, etc.).
- Fastenings are designed in accordance with:  
EN 1992-4:2018 and EOTA Technical Report TR 055, Edition February 2018.

### Installation:

- Fastener installation is to be carried out by appropriately qualified personnel and under the supervision of the person responsible for technical matters of the site
- Fastening depth should be marked and adhered to installation
- Overhead installation is allowed (necessary equipment see installation instruction)

fischer injection system FIS VL

**Intended use**  
Specifications part 2

**Annex B 2**  
Appendix 9/ 24

**Table B3.1: Installation parameters for anchor rods**

Anchor rods		Thread	M6	M8	M10	M12	M16	M20	M24	M27	M30	
Nominal drill hole diameter	$d_0$	[mm]	8	10	12	14	18	24	28	30	35	
Drill hole depth	$h_0$		$h_0 \geq h_{ef}$									
Effective embedment depth	$h_{ef, min}$		50	60	60	70	80	90	96	108	120	
	$h_{ef, max}$		72	160	200	240	320	400	480	540	600	
Minimum spacing and minimum edge distance	$s_{min}$		40	40	45	55	65	85	105	125	140	
	$c_{min}$											
Diameter of the clearance hole of the fixture	pre-positioned installation $d_f$		7	9	12	14	18	22	26	30	33	
	push through installation $d_f$		9	12	14	16	20	26	30	33	40	
Minimum thickness of concrete member	$h_{min}$		$h_{ef} + 30 (\geq 100)$					$h_{ef} + 2d_0$				
Maximum installation torque	$\max T_{inst}$		[Nm]	5	10	20	40	60	120	150	200	300

**fischer anchor rod**

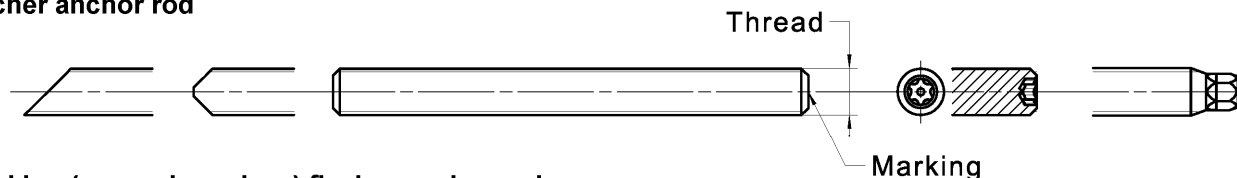

**Marking (on random place) fischer anchor rod:**

Steel zinc plated PC <sup>1)</sup> 8.8	• or +	Steel hot-dip PC <sup>1)</sup> 8.8	•
High corrosion resistant steel HCR PC <sup>1)</sup> 50	•	High corrosion resistant steel HCR PC <sup>1)</sup> 70	-
High corrosion resistant steel HCR PC <sup>1)</sup> 80	(	Stainless steel R property class 50 <sup>1)</sup>	~
Stainless steel R property class 80 <sup>1)</sup>	*		

Alternatively: Colour coding according to DIN 976-1: 2016

<sup>1)</sup>PC = property class

**Installation conditions:**

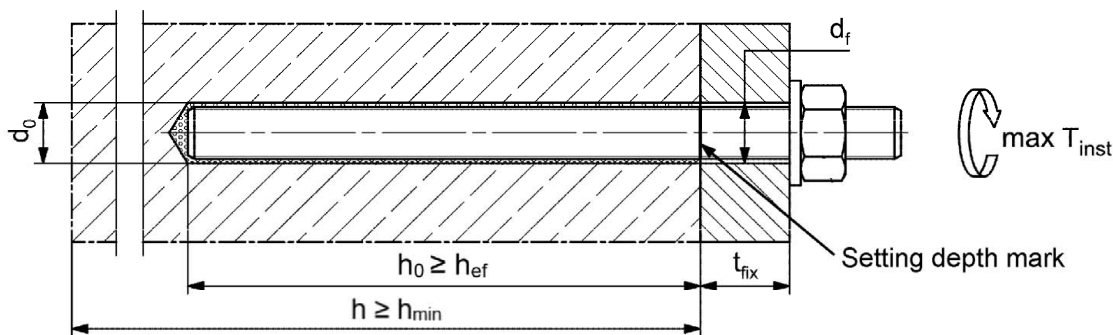

**Commercial standard threaded rods, washers and hexagon nuts may also be used if the following requirements are fulfilled:**

- Materials, dimensions and mechanical properties according to Annex A 5, Table A5.1
- Inspection certificate 3.1 according to EN 10204:2004, the documents have to be stored
- Setting depth is marked

Figures not to scale

fischer injection system FIS VL	<b>Annex B 3</b> Appendix 10/ 24
<b>Intended use</b> Installation parameters anchor rods	

**Table B4.1: Installation parameters for fischer internal threaded anchors RG M I**

Internal threaded anchors RG M I	Thread	M8	M10	M12	M16	M20
Diameter of anchor $d_{nom} = d_H$	[mm]	12	16	18	22	28
Nominal drill hole diameter $d_0$		14	18	20	24	32
Drill hole depth $h_0$		$h_0 \geq h_{ef} = L_H$				
Effective embedment depth ( $h_{ef} = L_H$ )		90	90	125	160	200
Minimum spacing and minimum edge distance $s_{min} = c_{min}$		55	65	75	95	125
Diameter of clearance hole in the fixture $d_f$		9	12	14	18	22
Minimum thickness of concrete member $h_{min}$		120	125	165	205	260
Maximum screw-in depth $l_{E,max}$		18	23	26	35	45
Minimum screw-in depth $l_{E,min}$		8	10	12	16	20
Maximum installation torque $\max T_{inst}$		[Nm]	10	20	40	80

**fischer internal threaded anchor RG M I**

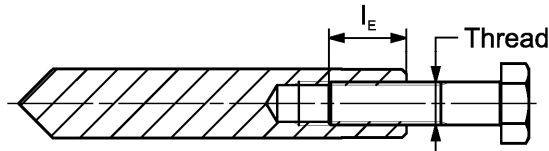
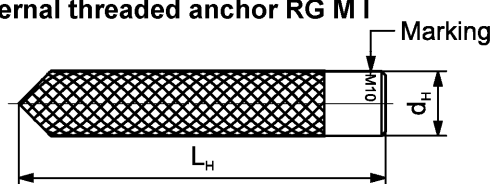

**Marking:**

- Anchor size e. g.: **M10**
- Stainless steel → additional **R**; e.g.: **M10 R**
- High corrosion resistant steel → additional **HCR**; e.g.: **M10 HCR**

Retaining bolt or threaded rods (including nut and washer) must comply with the appropriate material and strength class of Annex A 5, Table A5.1

**Installation conditions:**

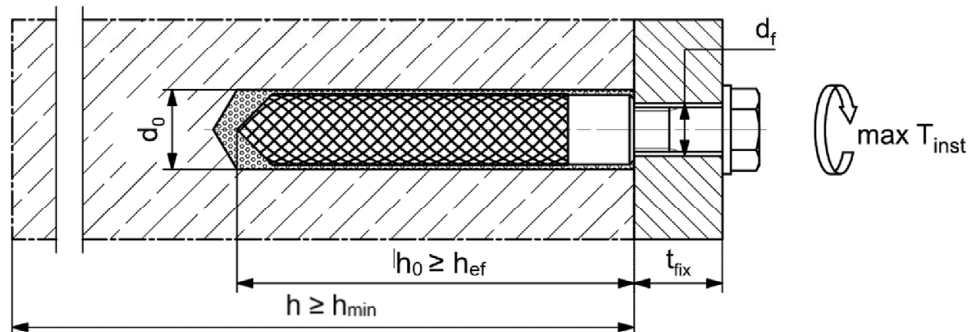

Figures not to scale

fischer injection system FIS VL

**Intended use**

Installation parameters internal threaded anchors RG M I

**Annex B 4**  
Appendix 11/24

**Table B5.1: Installation parameters for reinforcing bars**

Nominal diameter of the bar		$\phi$	8 <sup>1)</sup>		10 <sup>1)</sup>		12 <sup>1)</sup>		14	16	20
Nominal drill hole diameter	$d_0$	[mm]	10	12	12	14	14	16	18	20	25
Drill hole depth	$h_0$		$h_0 \geq h_{ef}$								
Effective embedment depth	$h_{ef,min}$		60	60	70	75	80	90			
	$h_{ef,max}$		160	200	240	280	320	400			
Minimum spacing and minimum edge distance	$s_{min} = c_{min}$		40	45	55	60	65	85			
Minimum thickness of concrete member	$h_{min}$	$h_{ef} + 30$ ( $\geq 100$ )					$h_{ef} + 2d_0$				

<sup>1)</sup> Both drill hole diameters can be used

**Reinforcing bar**



- The minimum value of related rib area  $f_{R,min}$  must fulfil the requirements of EN 1992-1-1:2004+AC:2010
- The rib height must be within the range:  $0,05 \cdot \phi \leq h_{rib} \leq 0,07 \cdot \phi$   
( $\phi$  = Nominal diameter of the bar,  $h_{rib}$  = rib height)

**Installation conditions:**

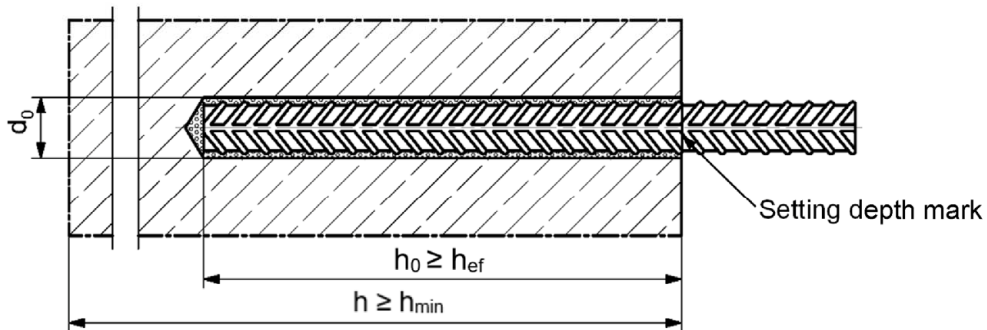

Figures not to scale

fischer injection system FIS VL

**Intended use**  
Installation parameters reinforcing bars

**Annex B 5**  
Appendix 12/ 24

**Table B6.1: Parameters of the cleaning brush BS (steel brush with steel bristles)**

The size of the cleaning brush refers to the drill hole diameter

Nominal drill hole diameter	$d_0$		8	10	12	14	16	18	20	24	25	28	30	35
Steel brush diameter BS	$d_b$	[mm]	9	11	14	16	20		25	26	27	30	40	

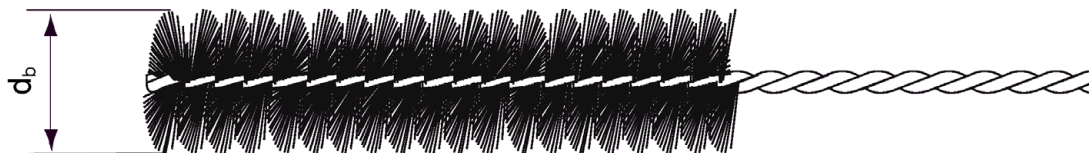

**Table B6.2 Maximum processing time of the mortar and minimum curing time**  
(During the curing time of the mortar the concrete temperature may not fall below the listed minimum temperature)

Temperature at anchoring base [°C]	Maximum processing time $t_{work}$			Minimum curing time <sup>1)</sup> $t_{cure}$		
	FIS VL High Speed	FIS VL	FIS VL Low Speed	FIS VL High Speed	FIS VL	FIS VL Low Speed
-10 to -5 <sup>2)</sup>	>5 min	-	-	12 h	-	-
> -5 to 0 <sup>2)</sup>	5 min	>13 min	-	3 h	24 h	-
> 0 to 5 <sup>2)</sup>	5 min	13 min	>20 min	3 h	3 h	6 h
> 5 to 10	3 min	9 min	20 min	50 min	90 min	3 h
> 10 to 20	1 min	5 min	10 min	30 min	60 min	2 h
> 20 to 30	-	4 min	6 min	-	45 min	60 min
> 30 to 40	-	2 min	4 min	-	35 min	30 min

<sup>1)</sup> In wet concrete or water filled holes the curing times must be doubled

<sup>2)</sup> Minimal cartridge temperature +5°C

# Installation instructions part 1

## Drilling and cleaning the hole (hammer drilling with standard drill bit)

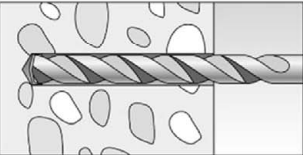
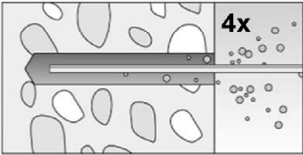
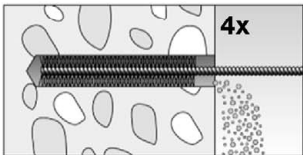
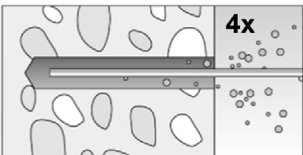
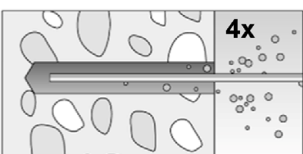
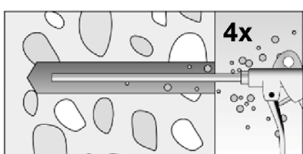
1		<p>Drill the hole. Nominal drill hole diameter <math>d_0</math> and drill hole depth <math>h_0</math> see <b>tables B3.1, B4.1, B5.1</b></p>
2		 <p>Clean the drill hole: For <math>h_{ef} \leq 12d</math> and <math>d_0 &lt; 18</math> mm blow out the hole four times by hand</p> <p>For <math>h_{ef} &gt; 12d</math> and / or <math>d_0 \geq 18</math> mm blow out the hole four times with oil-free compressed air (<math>p \geq 6</math> bar)</p>
3		<p>Brush the drill hole four times. For drill hole diameter <math>\geq 30</math> mm use a power drill. For deep holes use an extension. Corresponding brushes see <b>table B6.1</b></p>
4		 <p>Clean the drill hole: For <math>h_{ef} \leq 12d</math> and <math>d_0 &lt; 18</math> mm blow out the hole four times by hand</p> <p>For <math>h_{ef} &gt; 12d</math> and / or <math>d_0 \geq 18</math> mm blow out the hole four times with oil-free compressed air (<math>p \geq 6</math> bar)</p>

Go to step 5

## Drilling and cleaning the hole (hammer drilling with hollow drill bit)

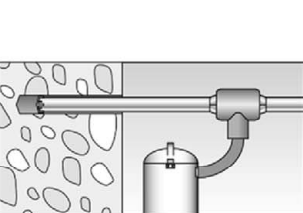
1		<p>Check a suitable hollow drill (see <b>table B1.1</b>) for correct operation of the dust extraction</p>
2		<p>Use a suitable dust extraction system, e.g. fischer FVC 35 M or a comparable dust extraction system with equivalent performance data</p> <p>Drill the hole with hollow drill bit. The dust extraction system has to extract the drill dust nonstop during the drilling process and must be adjusted to maximum power. Nominal drill hole diameter <math>d_0</math> and drill hole depth <math>h_0</math> see <b>tables B3.1, B4.1, B5.1</b></p>

Go to step 5

<p>fischer injection system FIS VL</p>	<p><b>Annex B 7</b> Appendix 14/ 24</p>
<p><b>Intended use</b> Installation instructions part 1</p>	



## Installation instructions part 2

### Preparing the cartridge

5

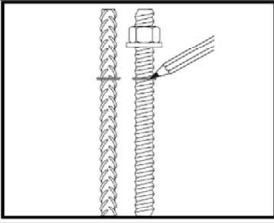

Mark the setting depth.

6

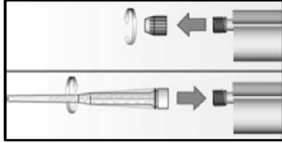

Remove the sealing cap  
Screw on the static mixer  
(the spiral in the static mixer must be clearly visible)

7

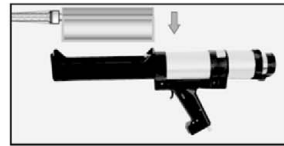
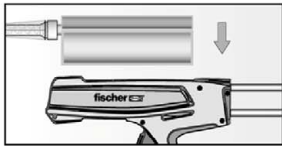

Place the cartridge into the dispenser

8

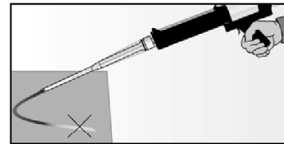
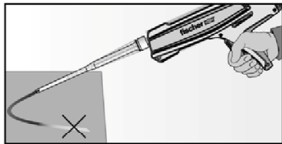

Extrude approximately 10 cm of material out until the resin is evenly grey in colour. Do not use mortar that is not uniformly grey

Go to step 9

### Injection of the mortar

9

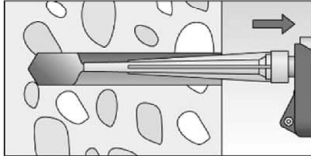

For  $h_0 = h_{ef}$  fill approximately 2/3 of the drill hole with mortar. For  $h_0 > h_{ef}$  more mortar is needed. Always begin from the bottom of the hole and avoid bubbles

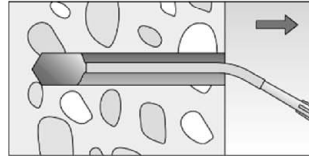

For drill hole depth  $\geq 150$  mm use an extension tube

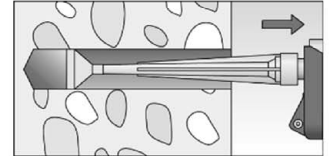

For overhead installation, deep holes ( $h_0 > 250$  mm) use an injection adapter

Go to step 10



fischer injection system FIS VL

**Intended use**  
Installation instructions part 2

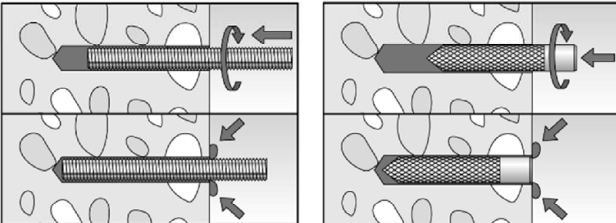
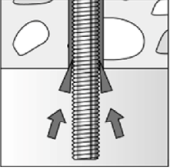
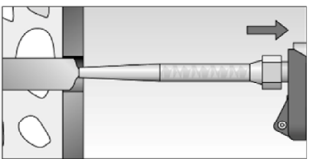

**Annex B 8**  
Appendix 15/ 24

### Installation instructions part 3

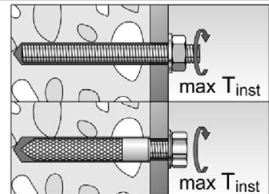
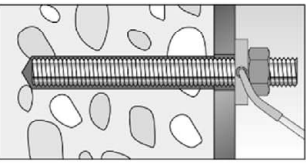
#### Installation of anchor rods or fischer internal threaded anchors RG M I

10		<p>Only use clean and oil-free metal parts. Push the anchor rod or fischer internal threaded RG M I anchor down to the bottom of the hole, turning it slightly while doing so. After inserting the metal parts, excess mortar must be emerged around the anchor element.</p>
	 <p>For overhead installations support the metal part with wedges (e.g. fischer centering wedges) or fischer overhead clips.</p>	 <p>For push through installation fill the annular gap with mortar</p>
11	 <p>Wait for the specified curing time <math>t_{cure}</math> see <b>table B6.2</b></p>	<p>12</p>  <p>Mounting the fixture <math>\max T_{inst}</math> see <b>tables B3.1 and B4.1</b></p>
Option		<p>After the minimum curing time is reached, the gap between metal part and fixture (annular clearance) may be filled with mortar via the fischer filling disc. Compressive strength <math>\geq 50 \text{ N/mm}^2</math> (e.g. fischer injection mortars FIS VL, FIS HB, FIS SB, FIS V, FIS V Plus, FIS EM Plus).  <b>ATTENTION:</b> Using fischer filling disc reduces <math>t_{fix}</math> (usable length of the anchor)</p>

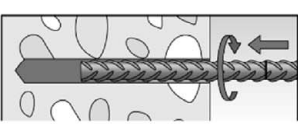
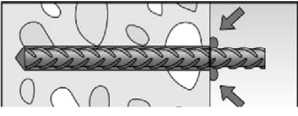
#### Installation reinforcing bars

10		<p>Only use clean and oil-free reinforcing bars. Push the reinforcement bar with the setting depth mark into the filled hole up to the setting depth mark. Recommendation: Rotation back and forth of the reinforcement bar or the fischer rebar anchor makes pushing easy</p>
		<p>When the setting depth mark is reached, excess mortar must be emerged from the mouth of the drill hole.</p>
11	 <p>Wait for the specified curing time <math>t_{cure}</math> see <b>table B6.2</b></p>	

fischer injection system FIS VL	<p><b>Annex B 9</b> Appendix 16/ 24</p>
<p><b>Intended use</b> Installation instructions part 3</p>	

**Table C1.1: Characteristic resistance to steel failure under tension / shear loading of fischer anchor rods and standard threaded rods**

Anchor rod / standard threaded rod		M6	M8	M10	M12	M16	M20	M24	M27	M30			
<b>Characteristic resistance to steel failure under tension loading <sup>3)</sup></b>													
Characteristic resistance $N_{Rk,s}$	Steel zinc plated	Property class	4.8	[kN]	8	15(13)	23(21)	33	63	98	141	184	224
			5.8		10	19(17)	29(27)	43	79	123	177	230	281
			8.8		16	29(27)	47(43)	68	126	196	282	368	449
	Stainless steel R and high corrosion resistant steel HCR		50		10	19	29	43	79	123	177	230	281
			70		14	26	41	59	110	172	247	322	393
			80		16	30	47	68	126	196	282	368	449
<b>Partial factors <sup>1)</sup></b>													
Partial factor $\gamma_{Ms,N}$	Steel zinc plated	Property class	4.8	[-]	1,50								
			5.8		1,50								
			8.8		1,50								
	Stainless steel R and high corrosion resistant steel HCR		50		2,86								
			70		1,50 <sup>2)</sup> / 1,87								
			80		1,60								
<b>Characteristic resistance to steel failure under shear loading <sup>3)</sup></b>													
<b>without lever arm</b>													
Characteristic resistance $V_{Rk,s}^0$	Steel zinc plated	Property class	4.8	[kN]	4	9(8)	14(13)	20	38	59	85	110	135
			5.8		6	11(10)	17(16)	25	47	74	106	138	168
			8.8		8	15(13)	23(21)	34	63	98	141	184	225
	Stainless steel R and high corrosion resistant steel HCR		50		5	9	15	21	39	61	89	115	141
			70		7	13	20	30	55	86	124	161	197
			80		8	15	23	34	63	98	141	184	225
Ductility factor	$k_7$	[-]	1,0										
<b>with lever arm</b>													
Characteristic resistance $M_{Rk,s}^0$	Steel zinc plated	Property class	4.8	[Nm]	6	15(13)	30(27)	52	133	259	448	665	899
			5.8		7	19(16)	37(33)	65	166	324	560	833	1123
			8.8		12	30(26)	60(53)	105	266	519	896	1333	1797
	Stainless steel R and high corrosion resistant steel HCR		50		7	19	37	65	166	324	560	833	1123
			70		10	26	52	92	232	454	784	1167	1573
			80		12	30	60	105	266	519	896	1333	1797
<b>Partial factors <sup>1)</sup></b>													
Partial factor $\gamma_{Ms,V}$	Steel zinc plated	Property class	4.8	[-]	1,25								
			5.8		1,25								
			8.8		1,25								
	Stainless steel R and high corrosion resistant steel HCR		50		2,38								
			70		1,25 <sup>2)</sup> / 1,56								
			80		1,33								

<sup>1)</sup> In absence of other national regulations

<sup>2)</sup> Only admissible for high corrosion resist. steel HCR, with  $f_{yk} / f_{uk} \geq 0,8$  and  $A_5 > 12 \%$  (e.g. fischer anchor rods)

<sup>3)</sup> Values in brackets are valid for undersized threaded rods with smaller stress area  $A_s$  for hot dip galvanized threaded rods according to EN ISO 10684:2004+AC:2009

**Table C2.1: Characteristic resistance to steel failure under tension / shear loading of fischer internal threaded anchors RG M I**

fischer internal threaded anchors RG M I				M8	M10	M12	M16	M20
<b>Characteristic resistance to steel failure under tension loading</b>								
Charact. resistance with screw	$N_{Rk,s}$	Property class 5.8	[kN]	19	29	43	79	123
		8.8		29	47	68	108	179
		Property class 70 R		26	41	59	110	172
		HCR		26	41	59	110	172
<b>Partial factors<sup>1)</sup></b>								
Partial factors	$\gamma_{Ms,N}$	Property class 5.8	[-]	1,50				
		8.8		1,50				
		Property class 70 R		1,87				
		HCR		1,87				
<b>Characteristic resistance to steel failure under shear loading</b>								
<b>Without lever arm</b>								
Charact. resistance with screw	$V^0_{Rk,s}$	Property class 5.8	[kN]	9,2	14,5	21,1	39,2	62,0
		8.8		14,6	23,2	33,7	54,0	90,0
		Property class 70 R		12,8	20,3	29,5	54,8	86,0
		HCR		12,8	20,3	29,5	54,8	86,0
Ductility factor			$k_7$	[-] 1,0				
<b>With lever arm</b>								
Charact. resistance with screw	$M^0_{Rk,s}$	Property class 5.8	[Nm]	20	39	68	173	337
		8.8		30	60	105	266	519
		Property class 70 R		26	52	92	232	454
		HCR		26	52	92	232	454
<b>Partial factors<sup>1)</sup></b>								
Partial factors	$\gamma_{Ms,V}$	Property class 5.8	[-]	1,25				
		8.8		1,25				
		Property class 70 R		1,56				
		HCR		1,56				

<sup>1)</sup> In absence of other national regulations

**Table C3.1: Characteristic resistance to steel failure under tension / shear loading of reinforcing bars**

Nominal diameter of the bar		$\phi$	8	10	12	14	16	20
<b>Characteristic resistance to steel failure under tension loading</b>								
Characteristic resistance	$N_{Rk,s}$	[kN]	$A_s \cdot f_{uk}^{2)}$					
<b>Characteristic resistance to steel failure under shear loading</b>								
<b>Without lever arm</b>								
Characteristic resistance	$V^0_{Rk,s}$	[kN]	$k_6^{1)} \cdot A_s \cdot f_{uk}^{2)}$					
Ductility factor	$k_7$	[-]	1,0					
<b>With lever arm</b>								
Characteristic resistance	$M^0_{Rk,s}$	[Nm]	$1,2 \cdot W_{el} \cdot f_{uk}^{2)}$					

- 1) In accordance with EN 1992-4:2018 section 7.2.2.3.1  
 $k_6 = 0,6$  for fasteners made of carbon steel with  $f_{uk} \leq 500 \text{ N/mm}^2$   
 $= 0,5$  for fasteners made of carbon steel with  $500 < f_{uk} \leq 1000 \text{ N/mm}^2$   
 $= 0,5$  for fasteners made of stainless steel
- 2)  $f_{uk}$  respectively must be taken from the specifications of the reinforcing bar

**Table C4.1: Characteristic resistance to concrete failure under tension / shear loading**

Size		All sizes									
<b>Characteristic resistance to concrete failure under tension loading</b>											
Installation factor	$\gamma_{inst}$	[-]	See annex C 5 to C 6								
<b>Factors for the compressive strength of concrete &gt; C20/25</b>											
Increasing factor $\psi_c$ for cracked or uncracked concrete $\tau_{Rk(X,Y)} = \psi_c \cdot \tau_{Rk(C20/25)}$	C25/30	[-]	1,05								
	C30/37		1,10								
	C35/45		1,15								
	C40/50		1,19								
	C45/55		1,22								
	C50/60		1,26								
<b>Splitting failure</b>											
Edge distance	$h / h_{ef} \geq 2,0$	$C_{cr,sp}$	[mm]	1,0 $h_{ef}$							
	$2,0 > h / h_{ef} > 1,3$			4,6 $h_{ef} - 1,8 h$							
	$h / h_{ef} \leq 1,3$			2,26 $h_{ef}$							
Spacing	$S_{cr,sp}$			2 $C_{cr,sp}$							
<b>Concrete failure</b>											
Uncracked concrete	$k_{ucr,N}$	[-]	11,0								
Cracked concrete	$k_{cr,N}$		7,7								
Edge distance	$C_{cr,N}$	[mm]	1,5 $h_{ef}$								
Spacing	$S_{cr,N}$		2 $C_{cr,N}$								
<b>Factors for sustained tension loading</b>											
Temperature range	[°C]	50 / 80				72 / 120					
Factor	$\psi_{sus}^0$	[-]	0,74				0,87				
<b>Characteristic resistance to concrete failure under shear loading</b>											
Installation factor	$\gamma_{inst}$	[-]	1,0								
<b>Concrete pry-out failure</b>											
Factor for pry-out failure	$k_8$	[-]	2,0								
<b>Concrete edge failure</b>											
Effective length of fastener in shear loading	$l_f$	[mm]	for $d_{nom} \leq 24$ mm: min ( $h_{ef}$ ; 12 $d_{nom}$ ) for $d_{nom} > 24$ mm: min ( $h_{ef}$ ; 8 $d_{nom}$ ; 300 mm)								
<b>Calculation diameters</b>											
Size			M6	M8	M10	M12	M16	M20	M24	M27	M30
fischer anchor rods and standard threaded rods	$d_{nom}$	[mm]	6	8	10	12	16	20	24	27	30
fischer internal threaded anchors RG M I	$d_{nom}$		- <sup>1)</sup>	12	16	18	22	28	- <sup>1)</sup>	- <sup>1)</sup>	- <sup>1)</sup>
Size (nominal diameter of the bar)	$\phi$	[mm]	8	10	12	14	16	20			
Reinforcing bar	$d_{nom}$		8	10	12	14	16	20			
<sup>1)</sup> Anchor type not part of this assessment											
fischer injection system FIS VL									<b>Annex C 4</b> Appendix 20/ 24		
<b>Performances</b> Characteristic resistance to concrete failure under tension / shear loading											

**Table C5.1: Characteristic resistance to combined pull-out and concrete failure for fischer anchor rods and standard threaded rods in hammer drilled holes; uncracked or cracked concrete**

Anchor rod / standard threaded rod		M6	M8	M10	M12	M16	M20	M24	M27	M30		
<b>Combined pull-out and concrete cone failure</b>												
Calculation diameter	d	[mm]	6	8	10	12	16	20	24	27	30	
<b>Uncracked concrete</b>												
<b>Characteristic bond resistance in uncracked concrete C20/25</b>												
Hammer-drilling with standard drill bit or hollow drill bit (dry or wet concrete)												
Temperature range	I: 50 °C / 80 °C	$\tau_{Rk,ucr}$	[N/mm <sup>2</sup> ]	9,0	11,0	11,0	11,0	10,0	9,5	9,0	8,5	8,5
	II: 72 °C / 120 °C			6,5	9,5	9,5	9,0	8,5	8,0	7,5	7,0	7,0
Hammer-drilling with standard drill bit or hollow drill bit (water filled hole)												
Temperature range	I: 50 °C / 80 °C	$\tau_{Rk,ucr}$	[N/mm <sup>2</sup> ]	- <sup>2)</sup>	- <sup>2)</sup>	- <sup>2)</sup>	9,5	8,5	8,0	7,5	7,0	7,0
	II: 72 °C / 120 °C			- <sup>2)</sup>	- <sup>2)</sup>	- <sup>2)</sup>	7,5	7,0	6,5	6,0	6,0	6,0
<b>Installation factors</b>												
Dry or wet concrete	$\gamma_{inst}$	[-]	1,0									
Water filled hole			- <sup>2)</sup>	- <sup>2)</sup>	- <sup>2)</sup>	1,2 <sup>1)</sup>						
<b>Cracked concrete</b>												
<b>Characteristic bond resistance in cracked concrete C20/25</b>												
Hammer-drilling with standard drill bit or hollow drill bit (dry or wet concrete)												
Temperature range	I: 50 °C / 80 °C	$\tau_{Rk,cr}$	[N/mm <sup>2</sup> ]	- <sup>2)</sup>	5,5	6,0	6,0	6,0	5,5	- <sup>2)</sup>	- <sup>2)</sup>	- <sup>2)</sup>
	II: 72 °C / 120 °C			- <sup>2)</sup>	4,5	5,0	6,0	6,0	5,0	- <sup>2)</sup>	- <sup>2)</sup>	- <sup>2)</sup>
Hammer-drilling with standard drill bit or hollow drill bit (water filled hole)												
Temperature range	I: 50 °C / 80 °C	$\tau_{Rk,cr}$	[N/mm <sup>2</sup> ]	- <sup>2)</sup>	- <sup>2)</sup>	- <sup>2)</sup>	5,0	5,0	4,5	- <sup>2)</sup>	- <sup>2)</sup>	- <sup>2)</sup>
	II: 72 °C / 120 °C			- <sup>2)</sup>	- <sup>2)</sup>	- <sup>2)</sup>	4,0	4,0	4,0	- <sup>2)</sup>	- <sup>2)</sup>	- <sup>2)</sup>
<b>Installation factors</b>												
Dry or wet concrete	$\gamma_{inst}$	[-]	- <sup>2)</sup>	1,0					- <sup>2)</sup>	- <sup>2)</sup>	- <sup>2)</sup>	
Water filled hole			- <sup>2)</sup>	- <sup>2)</sup>	- <sup>2)</sup>	1,2 <sup>1)</sup>			- <sup>2)</sup>	- <sup>2)</sup>	- <sup>2)</sup>	

<sup>1)</sup> Valid for shuttle cartridges with 360 ml, 825 ml and coaxial cartridges with 380 ml, 400 ml, 410 ml  
<sup>2)</sup> Performance not assessed

**Table C6.1: Characteristic resistance to combined pull-out and concrete failure for fischer internal threaded anchors RG M I in hammer drilled holes; uncracked concrete**

Internal threaded anchor RG M I			M8	M10	M12	M16	M20
<b>Combined pull-out and concrete cone failure</b>							
Calculation diameter	d	[mm]	12	16	18	22	28
<b>Uncracked concrete</b>							
<b>Characteristic bond resistance in uncracked concrete C20/25</b>							
<u>Hammer-drilling with standard drill bit or hollow drill bit (dry or wet concrete)</u>							
Temperature range	I: 50 °C / 80 °C	$\tau_{RK,ucr}$ [N/mm <sup>2</sup> ]	10,5	10,0	9,5	9,0	8,5
	II: 72 °C / 120 °C		9,0	8,0	8,0	7,5	7,0
<u>Hammer-drilling with standard drill bit or hollow drill bit (water filled hole)</u>							
Temperature range	I: 50 °C / 80 °C	$\tau_{RK,ucr}$ [N/mm <sup>2</sup> ]	10,0	9,0	9,0	8,5	8,0
	II: 72 °C / 120 °C		7,5	6,5	6,5	6,0	6,0
<b>Installation factors</b>							
Dry or wet concrete	$\gamma_{inst}$	[-]	1,0				
Water filled hole			1,2 <sup>1)</sup>				

<sup>1)</sup> Valid for shuttle cartridges with 360 ml, 825 ml and coaxial cartridges with 380 ml, 400 ml, 410 ml

**Table C6.2: Characteristic resistance to combined pull-out and concrete failure for reinforcing bars in hammer drilled holes; uncracked or cracked concrete**

Nominal diameter of the bar			$\phi$	8	10	12	14	16	20
<b>Combined pull-out and concrete cone failure</b>									
Calculation diameter	d	[mm]	8	10	12	14	16	20	
<b>Uncracked concrete</b>									
<b>Characteristic bond resistance in uncracked concrete C20/25</b>									
<u>Hammer-drilling with standard drill bit or hollow drill bit (dry or wet concrete)</u>									
Temperature range	I: 50 °C / 80 °C	$\tau_{RK,ucr}$ [N/mm <sup>2</sup> ]	11,0	11,0	11,0	10,0	10,0	9,5	
	II: 72 °C / 120 °C		9,5	9,5	9,0	8,5	8,5	8,0	
<b>Installation factor</b>									
Dry or wet concrete	$\gamma_{inst}$	[-]	1,0						
<b>Cracked concrete</b>									
<b>Characteristic bond resistance in cracked concrete C20/25</b>									
<u>Hammer-drilling with standard drill bit or hollow drill bit (dry or wet concrete)</u>									
Temperature range	I: 50 °C / 80 °C	$\tau_{RK,cr}$ [N/mm <sup>2</sup> ]	- <sup>1)</sup>	3,0	5,0	5,0	5,0	4,5	
	II: 72 °C / 120 °C		- <sup>1)</sup>	3,0	4,5	4,5	4,5	4,0	
<b>Installation factor</b>									
Dry or wet concrete	$\gamma_{inst}$	[-]	- <sup>1)</sup>	1,0					

<sup>1)</sup> Performance not assessed

fischer injection system FIS VL	<b>Annex C 6</b> Appendix 22/ 24
<b>Performances</b> Characteristic resistance to combined pull-out and concrete failure for fischer internal threaded anchors RG M I and reinforcing bars	



**Table C7.1: Displacements for anchor rods**

Anchor rod	M6	M8	M10	M12	M16	M20	M24	M27	M30	
<b>Displacement-Factors for tension loading<sup>1)</sup></b>										
<b>Uncracked concrete; Temperature range I, II</b>										
$\delta_{N0}$ -Factor	[mm/(N/mm <sup>2</sup> )]	0,09	0,09	0,09	0,10	0,10	0,10	0,10	0,11	0,12
$\delta_{N\infty}$ -Factor		0,10	0,10	0,10	0,12	0,12	0,12	0,13	0,13	0,14
<b>Cracked concrete; Temperature range I, II</b>										
$\delta_{N0}$ -Factor	[mm/(N/mm <sup>2</sup> )]	- <sup>3)</sup>	0,12	0,12	0,12	0,13	0,13	- <sup>3)</sup>	- <sup>3)</sup>	- <sup>3)</sup>
$\delta_{N\infty}$ -Factor		- <sup>3)</sup>	0,25	0,27	0,30	0,30	0,30	- <sup>3)</sup>	- <sup>3)</sup>	- <sup>3)</sup>
<b>Displacement-Factors for shear loading<sup>2)</sup></b>										
<b>Uncracked or cracked concrete; Temperature range I, II</b>										
$\delta_{V0}$ -Factor	[mm/kN]	0,11	0,11	0,11	0,10	0,10	0,09	0,09	0,08	0,07
$\delta_{V\infty}$ -Factor		0,12	0,12	0,12	0,11	0,11	0,10	0,10	0,09	0,09

1) Calculation of effective displacement:

$$\delta_{N0} = \delta_{N0\text{-Factor}} \cdot \tau$$

$$\delta_{N\infty} = \delta_{N\infty\text{-Factor}} \cdot \tau$$

$\tau$  = acting bond strength under tension loading

2) Calculation of effective displacement:

$$\delta_{V0} = \delta_{V0\text{-Factor}} \cdot V$$

$$\delta_{V\infty} = \delta_{V\infty\text{-Factor}} \cdot V$$

$V$  = acting shear loading

<sup>3)</sup> Performance not assessed

**Table C7.2: Displacements for fischer internal threaded anchors RG M I**

Internal threaded anchor RG M I	M8	M10	M12	M16	M20	
<b>Displacement-Factors for tension loading<sup>1)</sup></b>						
<b>Uncracked concrete; Temperature range I, II</b>						
$\delta_{N0}$ -Factor	0,10		0,11	0,12	0,13	0,14
$\delta_{N\infty}$ -Factor	0,13		0,14	0,15	0,16	0,18
<b>Displacement-Factors for shear loading<sup>2)</sup></b>						
<b>Uncracked concrete; Temperature range I, II</b>						
$\delta_{V0}$ -Factor	0,12		0,12	0,12	0,12	0,12
$\delta_{V\infty}$ -Factor	0,14		0,14	0,14	0,14	0,14

1) Calculation of effective displacement:

$$\delta_{N0} = \delta_{N0\text{-Factor}} \cdot \tau$$

$$\delta_{N\infty} = \delta_{N\infty\text{-Factor}} \cdot \tau$$

$\tau$  = acting bond strength under tension loading

2) Calculation of effective displacement:

$$\delta_{V0} = \delta_{V0\text{-Factor}} \cdot V$$

$$\delta_{V\infty} = \delta_{V\infty\text{-Factor}} \cdot V$$

$V$  = acting shear loading

fischer injection system FIS VL	<b>Annex C 7</b> Appendix 23/ 24
<b>Performances</b> Displacements for anchor rods and fischer internal threaded anchors RG M I	

**Table C8.1: Displacements for reinforcing bars**

Nominal diameter of the bar $\phi$		8	10	12	14	16	20
<b>Displacement-Factors for tension loading<sup>1)</sup></b>							
<b>Uncracked concrete; Temperature range I, II</b>							
$\delta_{N0}$ -Factor	[mm/(N/mm <sup>2</sup> )]	0,09	0,09	0,10	0,10	0,10	0,10
$\delta_{N\infty}$ -Factor		0,10	0,10	0,12	0,12	0,12	0,12
<b>Cracked concrete; Temperature range I, II</b>							
$\delta_{N0}$ -Factor	[mm/(N/mm <sup>2</sup> )]	- <sup>3)</sup>	0,12	0,13	0,13	0,13	0,13
$\delta_{N\infty}$ -Factor		- <sup>3)</sup>	0,27	0,30	0,30	0,30	0,30
<b>Displacement-Factors for shear loading<sup>2)</sup></b>							
<b>Uncracked or cracked concrete; Temperature range I, II</b>							
$\delta_{V0}$ -Factor	[mm/kN]	0,11	0,11	0,10	0,10	0,10	0,09
$\delta_{V\infty}$ -Factor		0,12	0,12	0,11	0,11	0,11	0,10
<sup>1)</sup> Calculation of effective displacement: $\delta_{N0} = \delta_{N0}\text{-Factor} \cdot \tau$ $\delta_{N\infty} = \delta_{N\infty}\text{-Factor} \cdot \tau$ $\tau =$ acting bond strength under tension loading				<sup>2)</sup> Calculation of effective displacement: $\delta_{V0} = \delta_{V0}\text{-Factor} \cdot V$ $\delta_{V\infty} = \delta_{V\infty}\text{-Factor} \cdot V$ $V =$ acting shear loading			
<sup>3)</sup> Performance not assessed							

fischer injection system FIS VL

**Performances**  
Displacements for reinforcing bars