

ROYAL B1

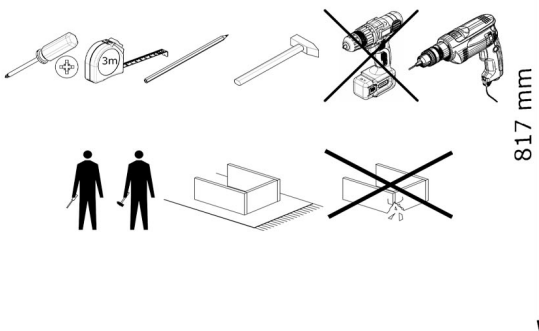

Vážený Zákazníku!

Před montáží nábytku si pečlivě přečtěte následující pokyny PRVKY NESOUČÍ STOPY MONTÁŽE REKLAMOVANÉ PRO MECHANICKÁ POŠKOZENÍ NEBO VADY NEPODLÉHAJÍ REKLAMACI V případě pochybnosti během montáže nás prosím kontaktujte. Nábytek se sestavuje podle následujících kroků uvedených v příručce. Kódy nalepené na částech nábytku odpovídají kódům v příručce. Pozor! Kolíky nabíjíme do úzké roviny prvku. Pozor! Zadní stěnu nábytku a spodní část zásuvky montujeme po nastavení úhlopříčky (viz obrázek)

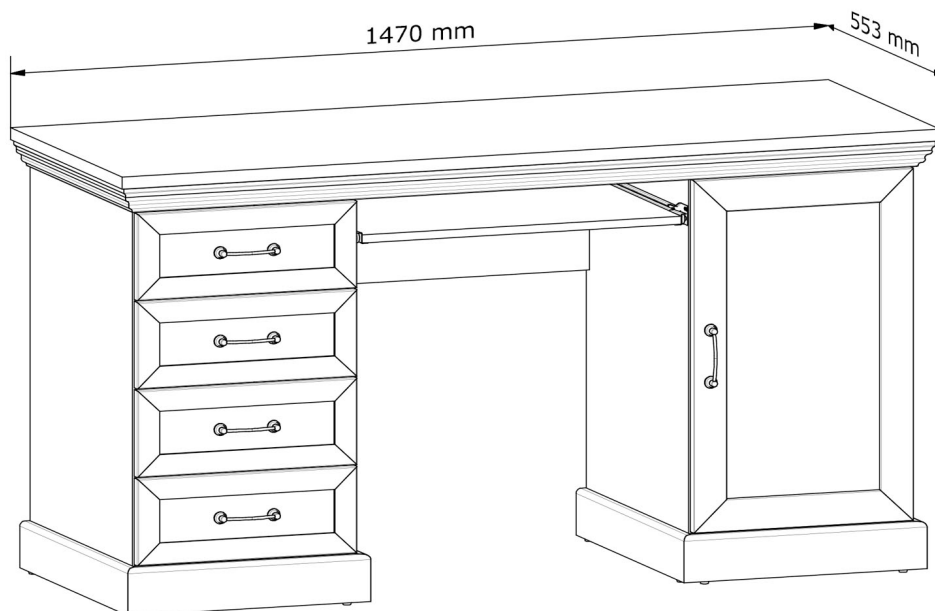
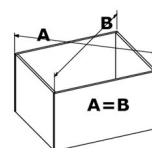

Posledním krokem je umístění nábytku na správné místo a pomocí vodováhy zkontrolování vertikální a horizontální polohy nábytku a nastavení čelních ploch na pantech. Tipy pro péči. Nábytek čistíme pouze prachovou utěrkou (suchou nebo vlhkou)! Nepoužívejte žádné chemické čisticí prostředky! Skleněné prvky prosím čištěte prostředky pro čištění skla, které jsou k dispozici na trhu, a jak je uvedeno na obalu vybraného produktu.

Pozor! Koloristika dekorativní lišty a obvodu nábytku se může mírně lišit od barvy desky. Závísí to na vārce produktu. Toto NENÍ základem pro reklamaci.

Pozor! Výrobce nábytku si vyhrazuje právo provádět konstrukční změny nabízeného nábytku, aniž by změnil jeho celkový charakter. Rozměry nábytku se mohou měnit.

VAROVÁNÍ TÝKAJÍCÍ SE SKLOPENÍ!

Tento výrobek musí být trvale připevněn na stěnu pomocí příložených držáků, aby nedošlo ke smrtelnému zranění, kdyby se sklopil. Sada obsahuje pouze šroubky pro upevnění držáků zabraňujících sklopení k výrobku. Ohledně správného typu vrutů/hmoždinek pro daný typ stěny se obraťte na vhodný obchod nebo železářství

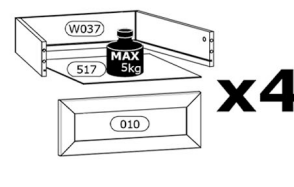
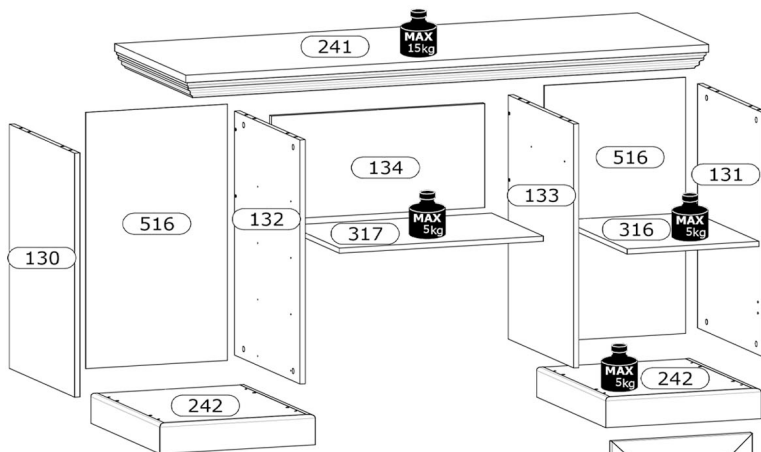
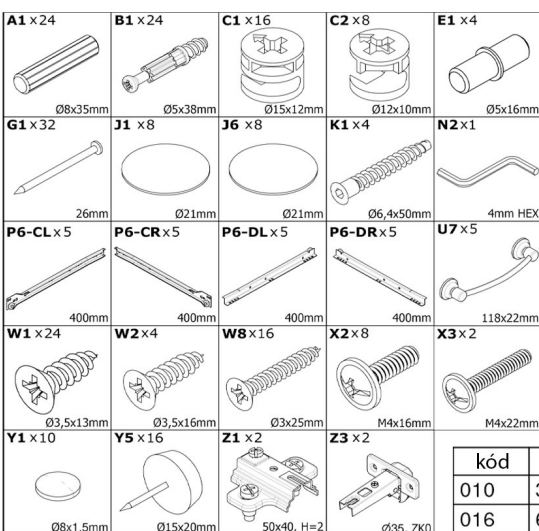
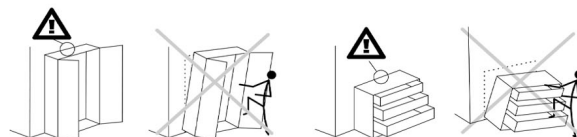

kód	L[mm]	W[mm]	H[mm]	PCS	balíček
010	395	160	18	4	2/3
016	650	395	18	1	2/3
W037	1144	100	12	4	1/3
130	705	505	15	1	1/3
131	705	505	15	1	1/3
132	705	505	15	1	1/3
133	705	505	15	1	1/3
134	600	300	15	1	1/3
241	1470	550	72	1	3/3
242	533,5	437	86	2	3/3
316	505	370	15	1	1/3
317	574	400	15	1	2/3
516	740	398	2,5	2	1/3
517	400	331	2,5	4	3/3

1

A1 x16

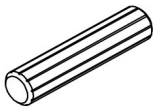

Ø8x35mm

C1 x16



Ø15x12mm

E1 x4

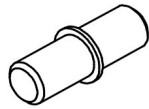

Ø5x16mm

Z1 x2



50x40, H=2

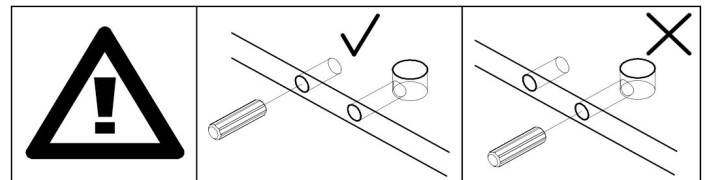
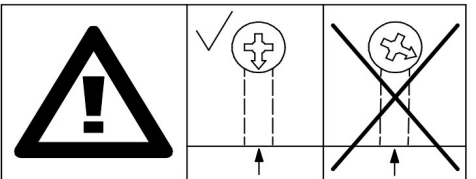
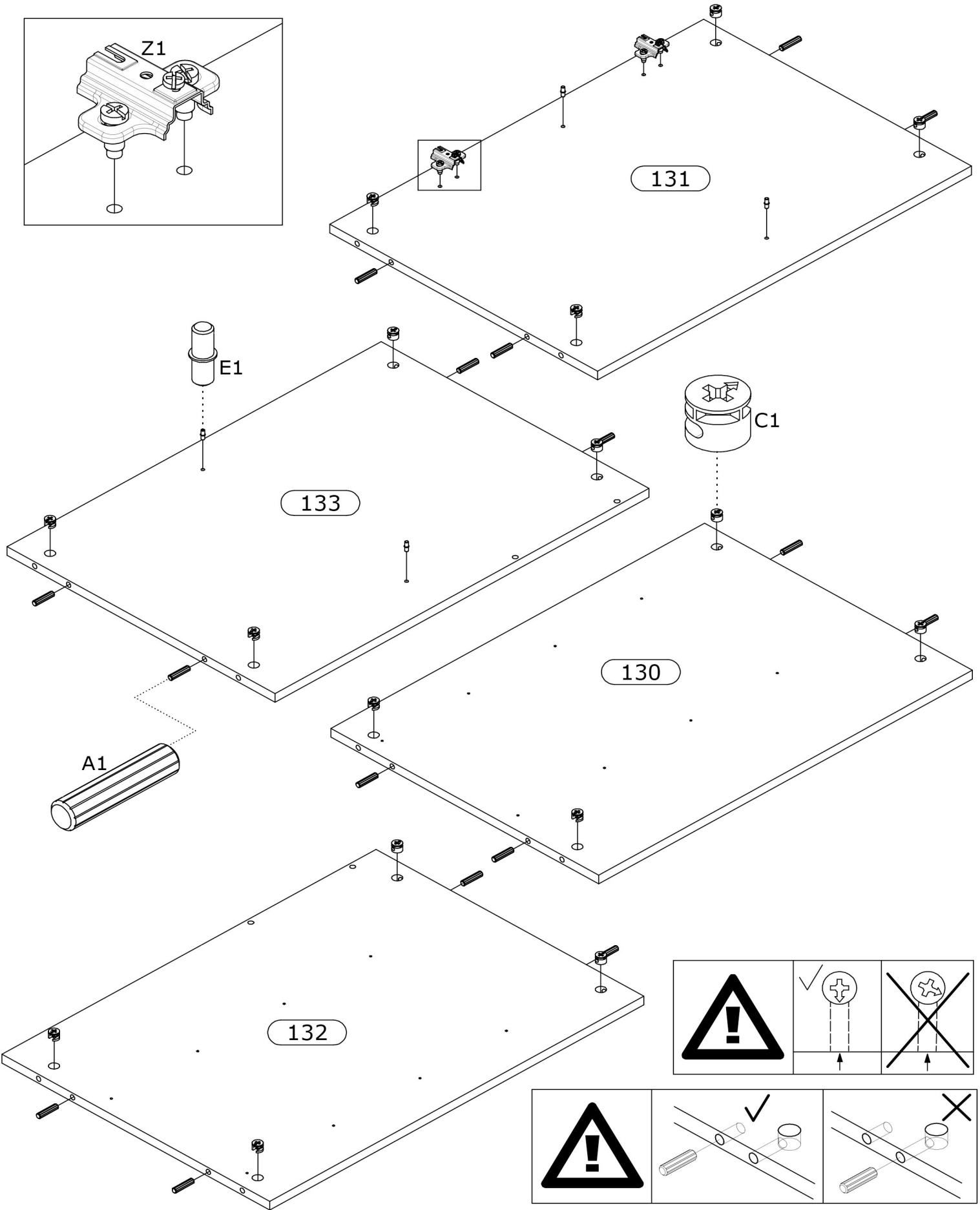
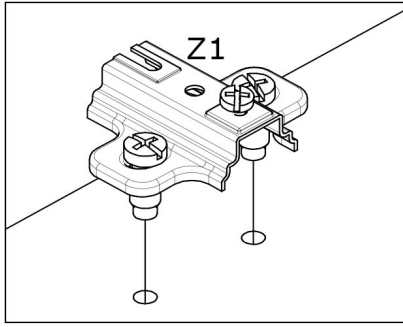
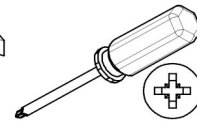
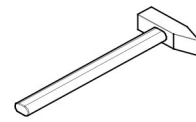

2

P6-CR x4

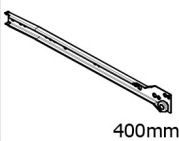

400mm

W1 x8

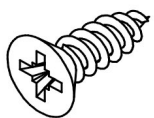

Ø3,5x13mm

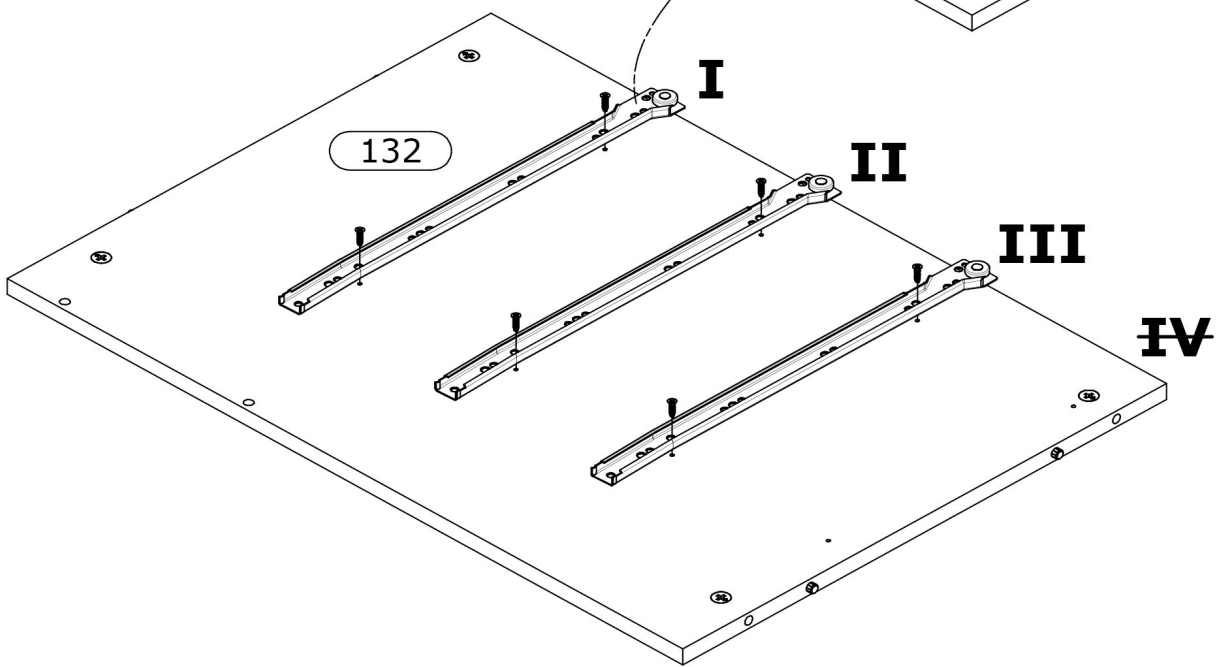
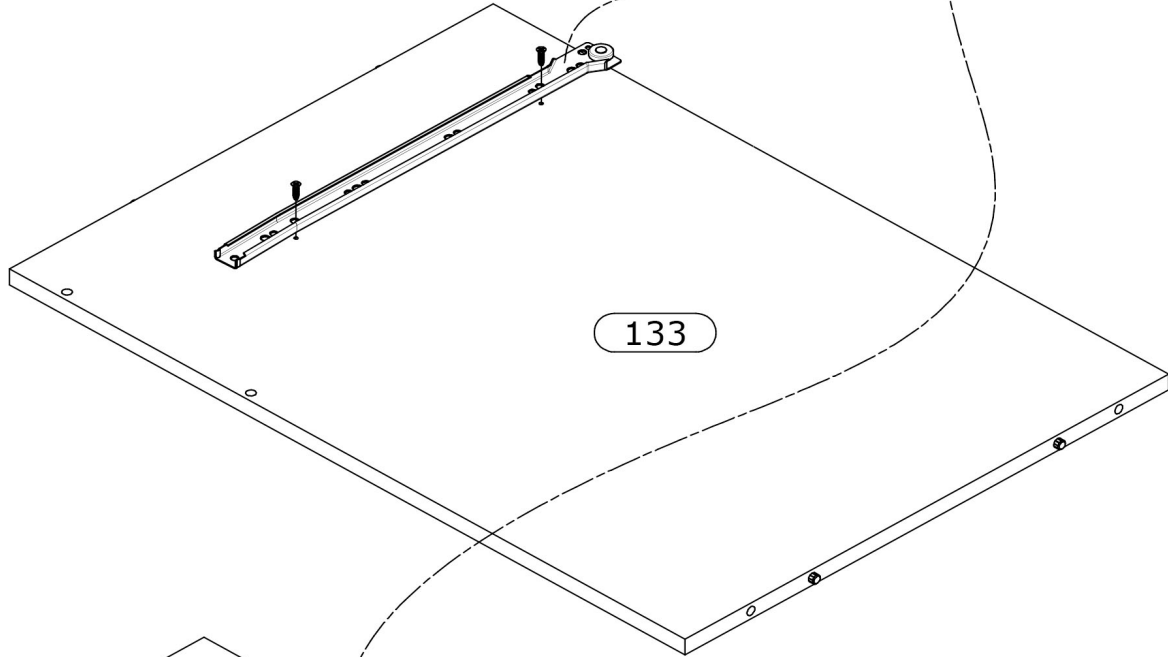
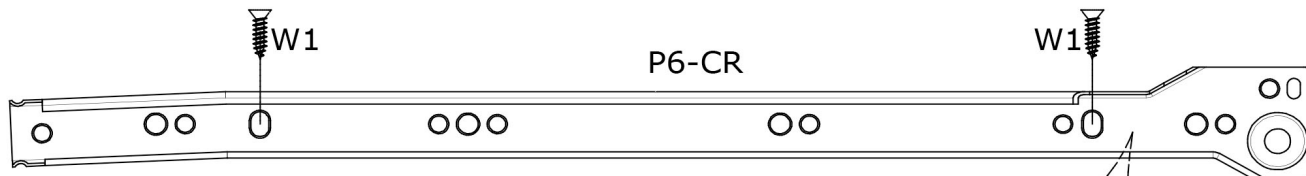
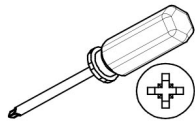

3

P6-CL x 4

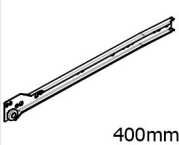

400mm

W1 x 8



Ø3,5x13mm

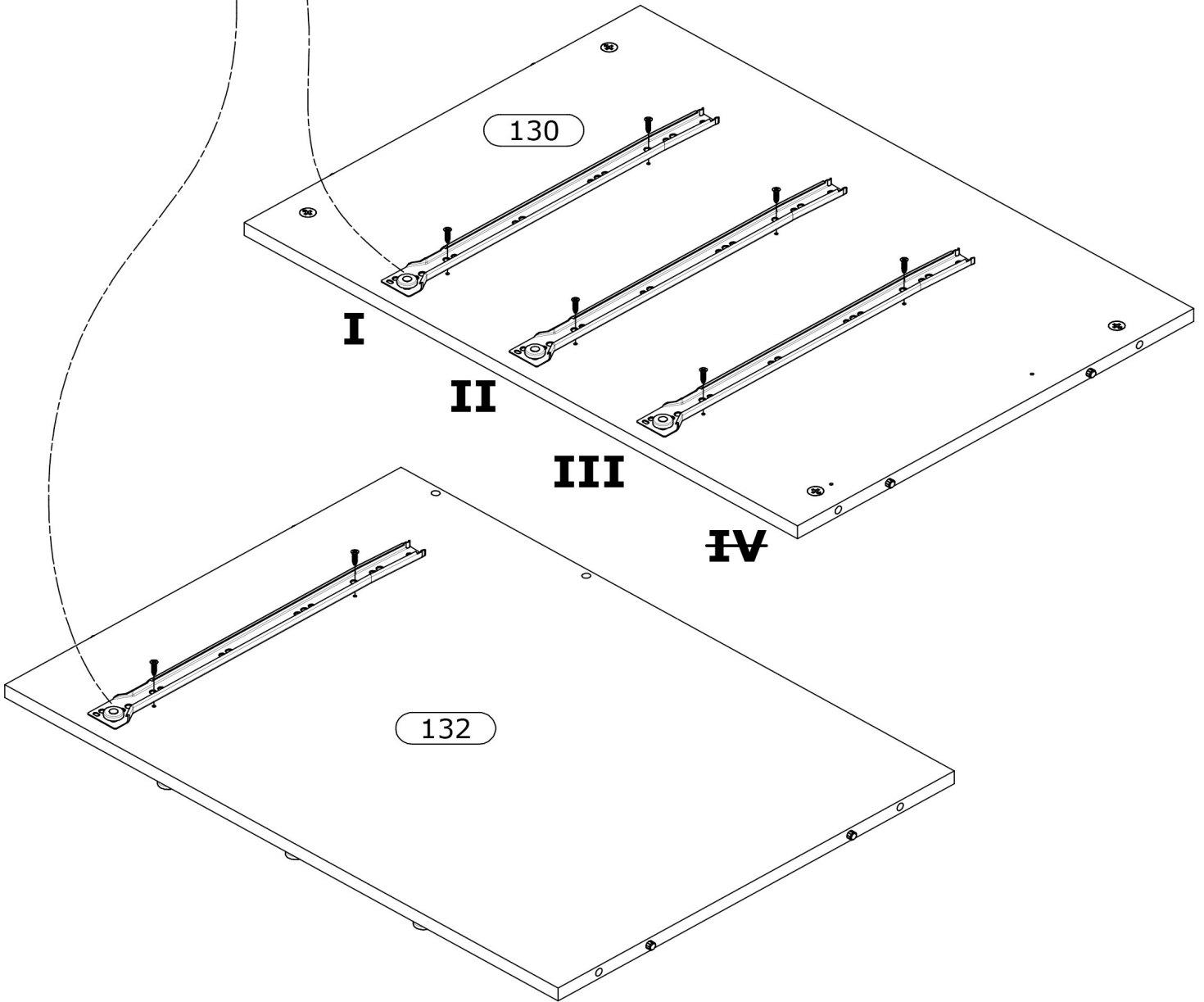
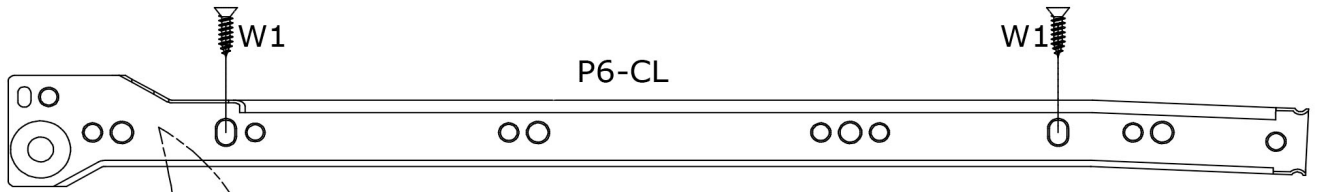
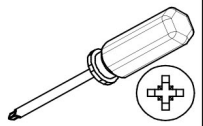

4

B1 x16
Ø5x38mm

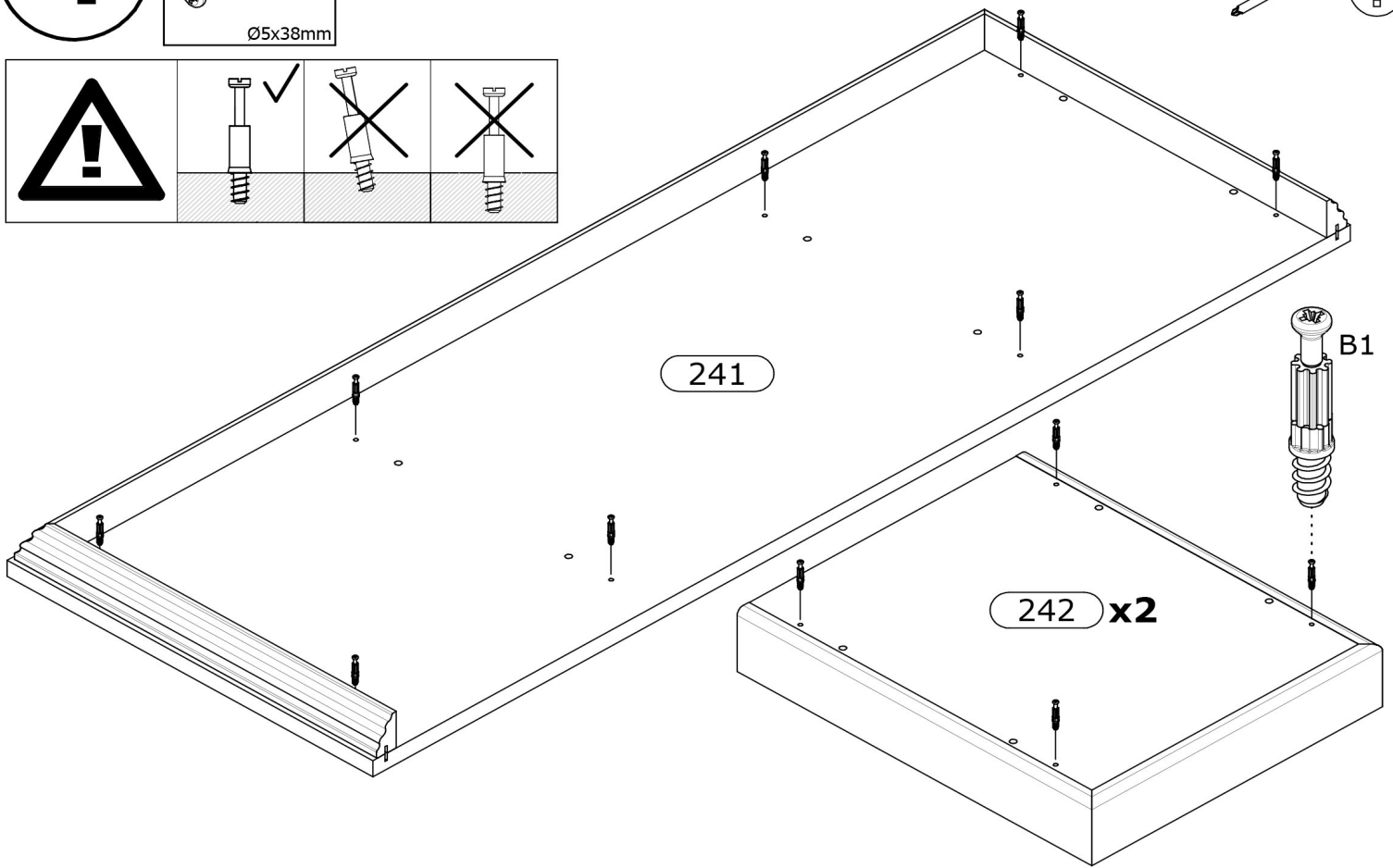
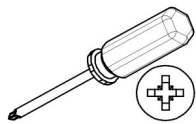
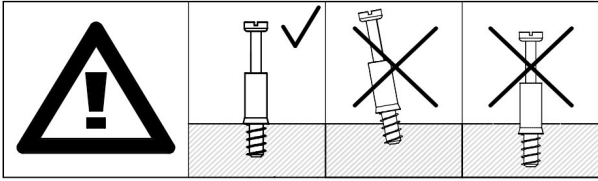

5

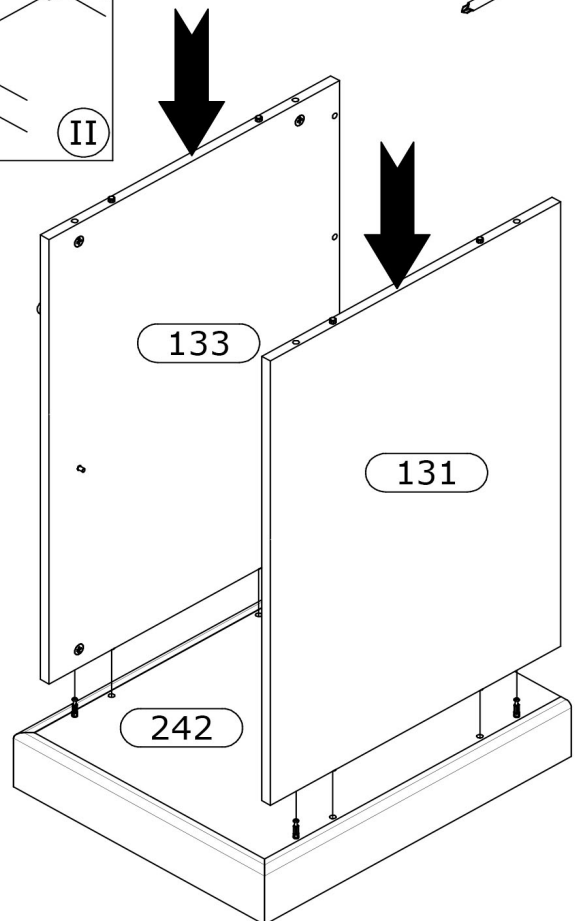
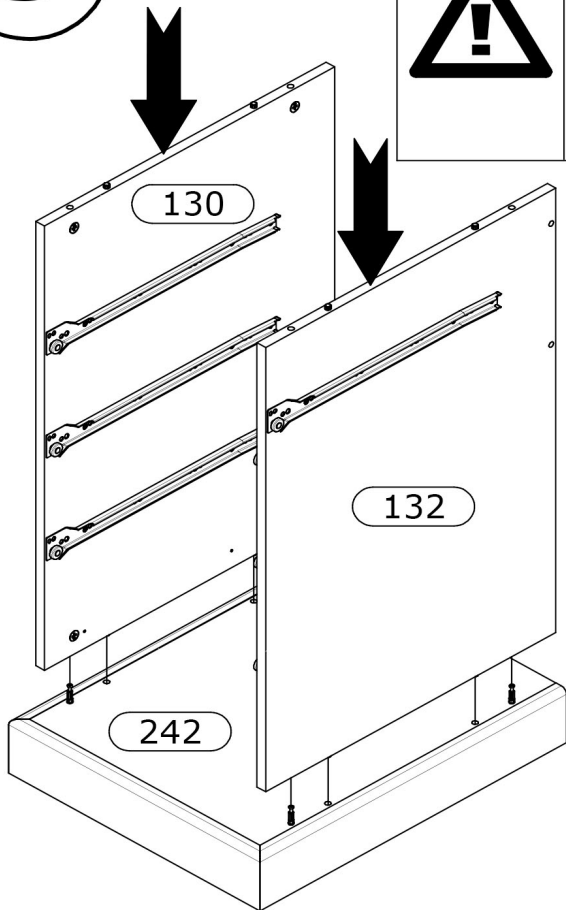
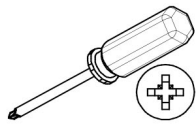
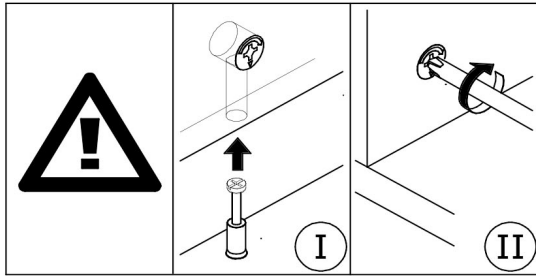

6

K1 x4

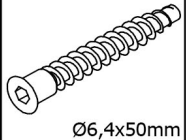

N2 x1



4mm HEX

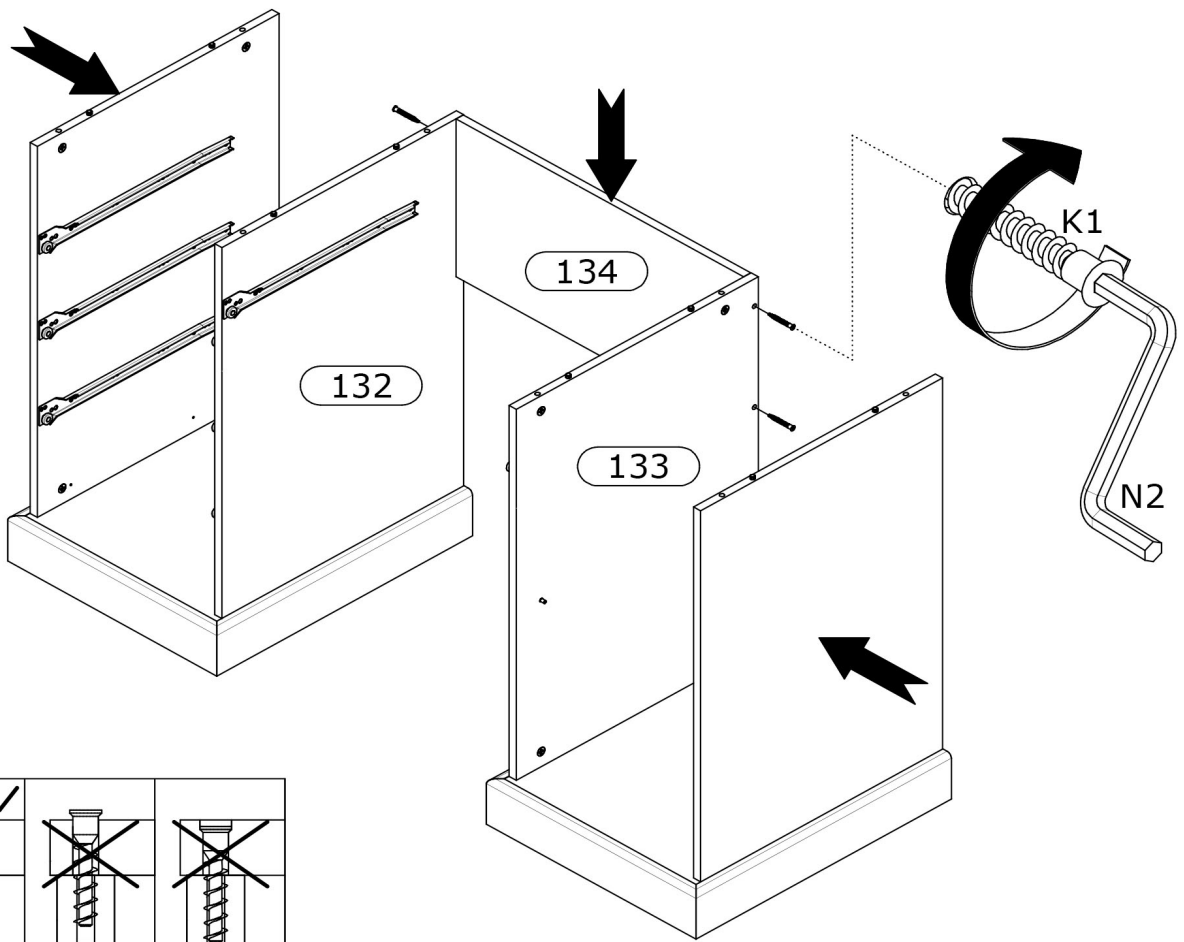

7

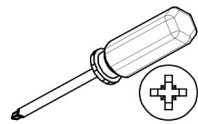
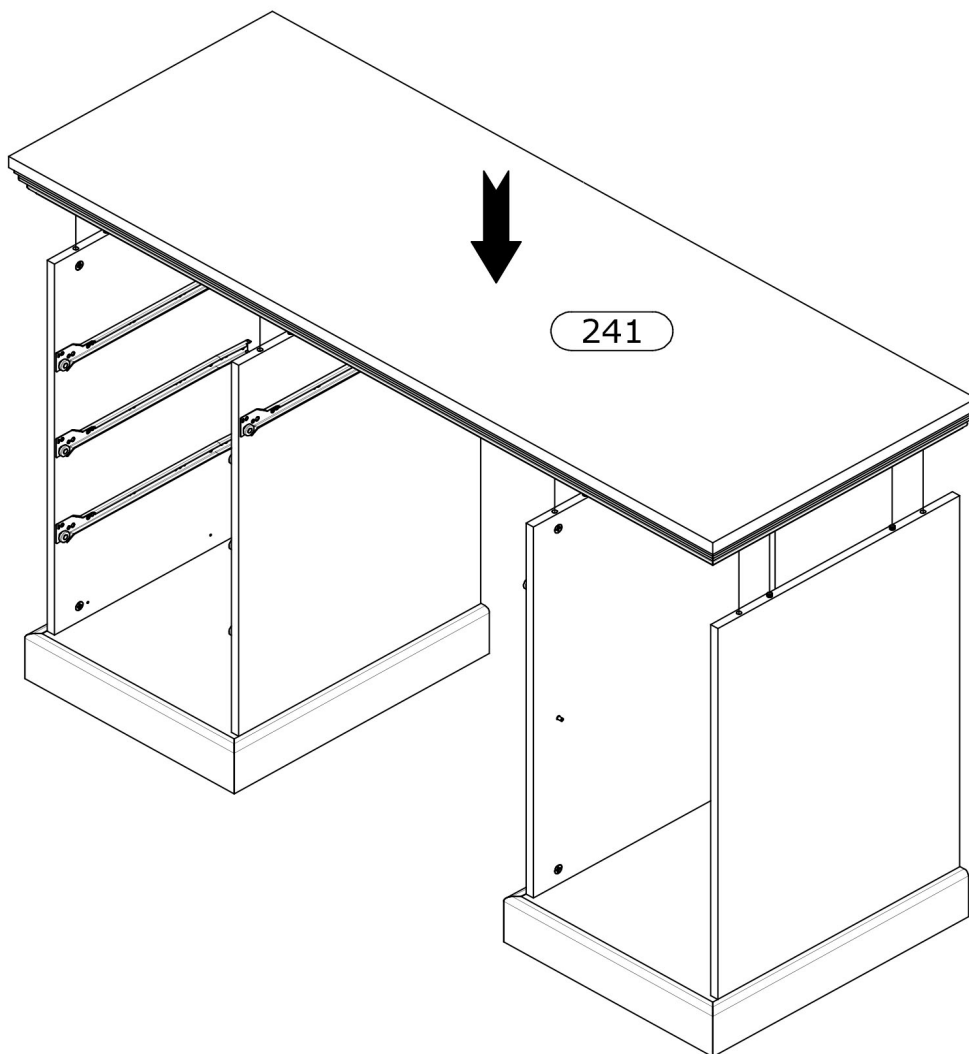

8

G1 x32

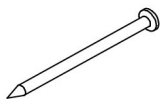

26mm

Y5 x16



Ø15x20mm

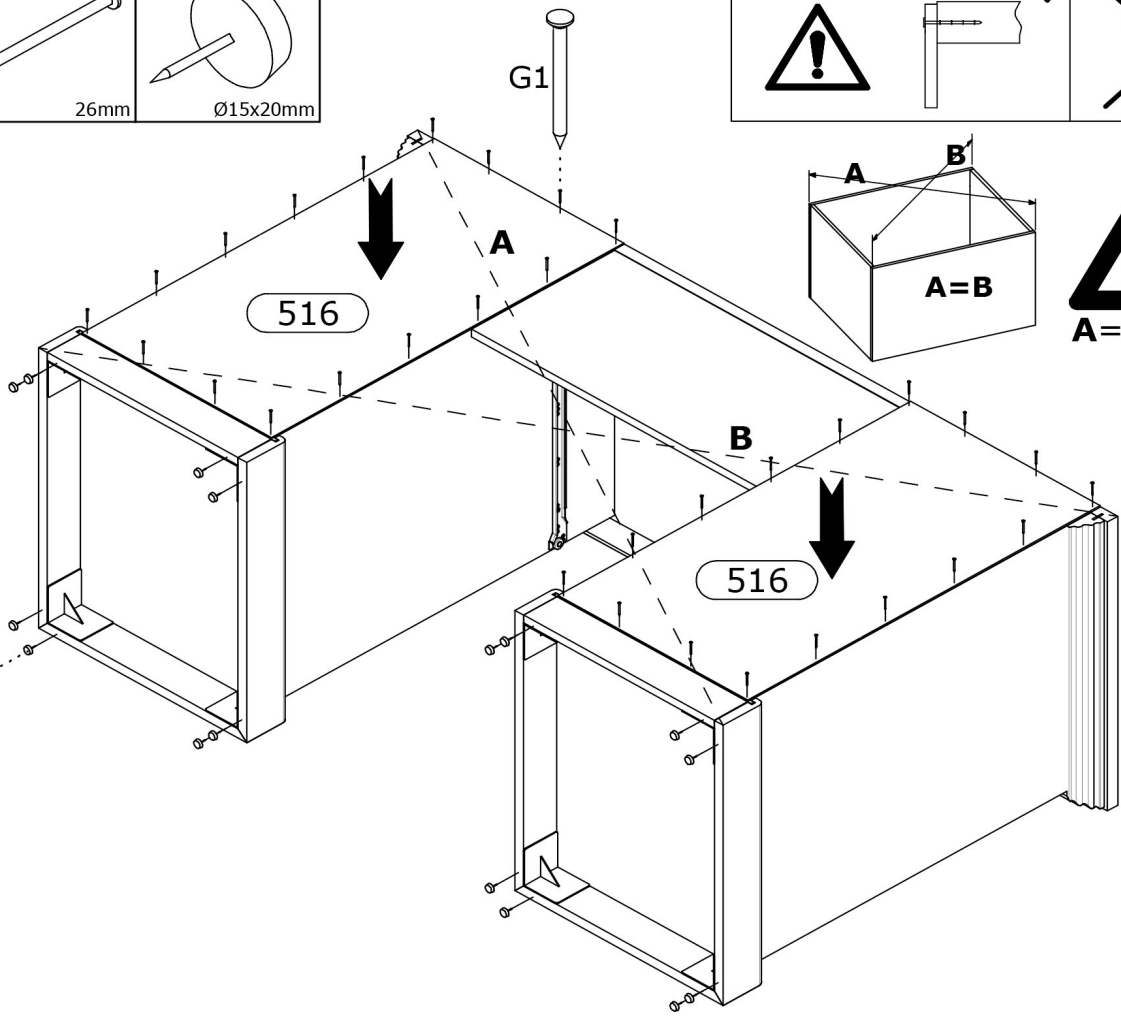
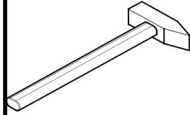
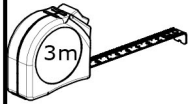
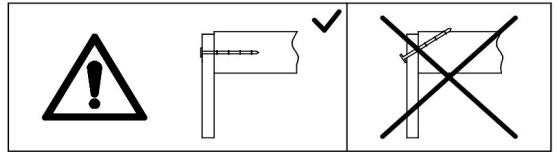

9

P6-CL x1



400mm

P6-CR x1



400mm

W1 x4



Ø3,5x13mm

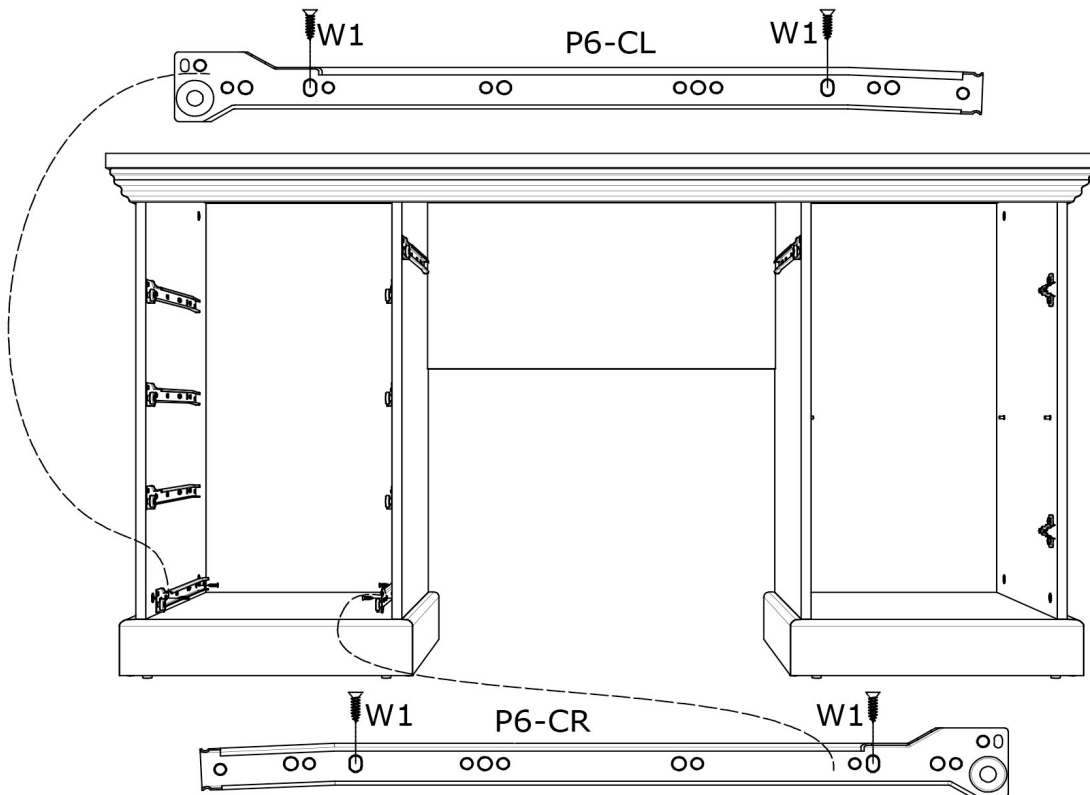
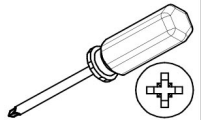

10

B1 x8

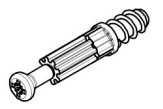

Ø5x38mm

Y1 x8



Ø8x1,5mm

Y1

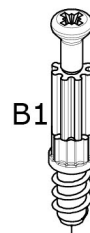

B1

010

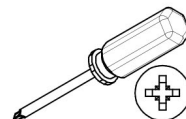

x4

11

A1 x8

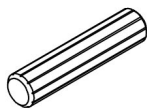

Ø8x35mm

C2 x8



Ø12x10mm

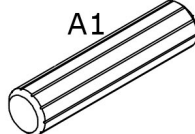

A1



C2

W037

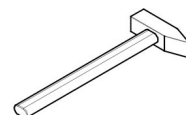

x4

12

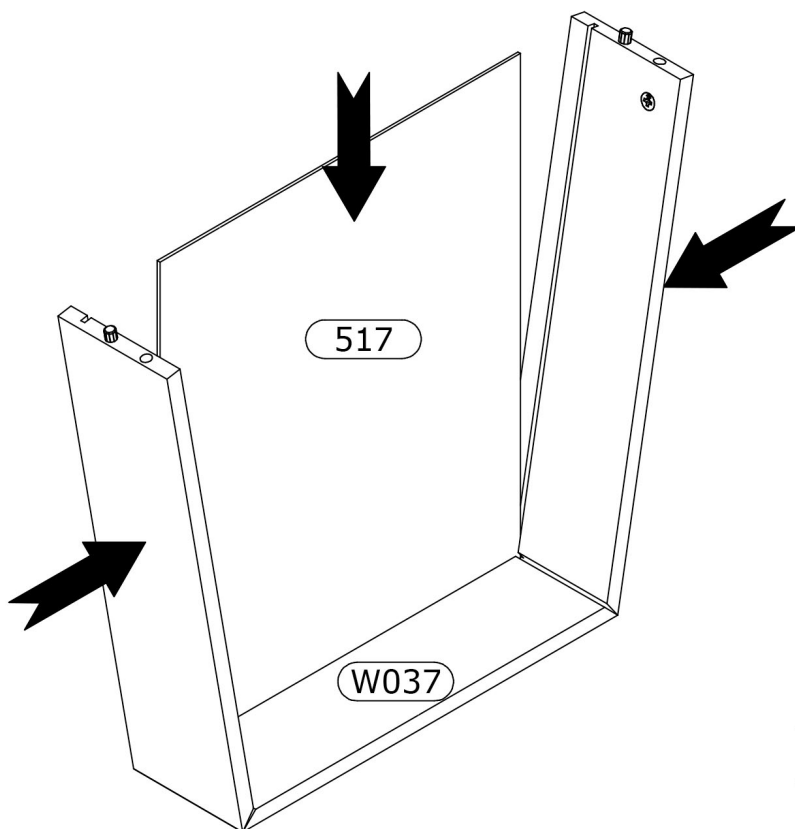

x4

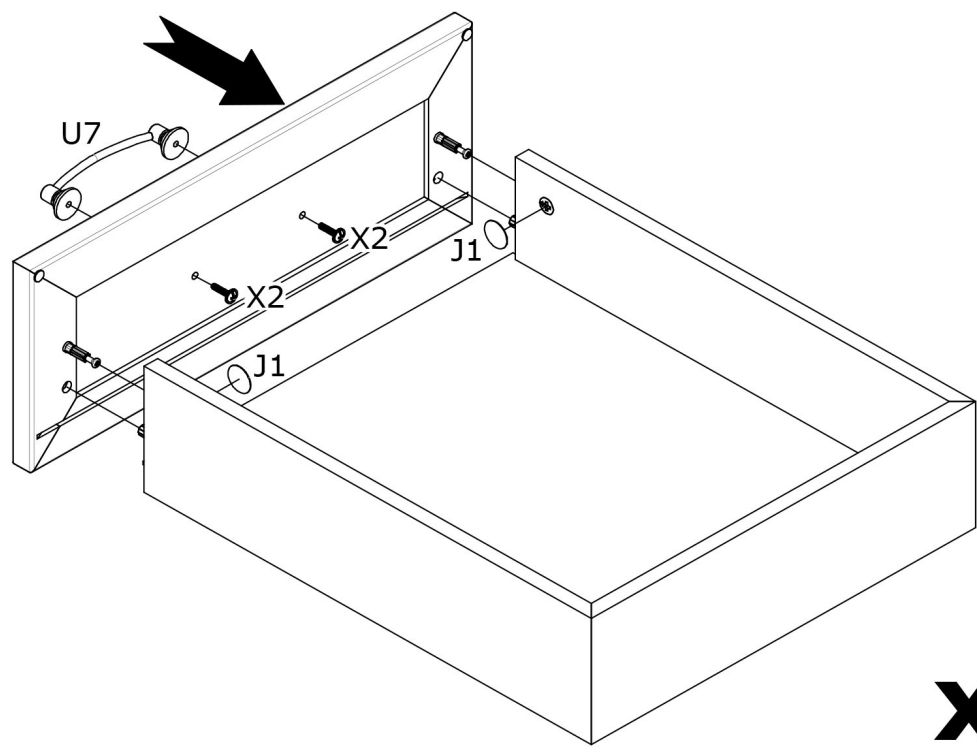
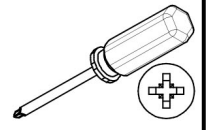
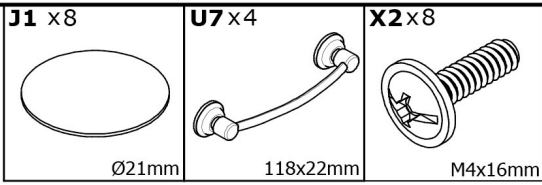

13

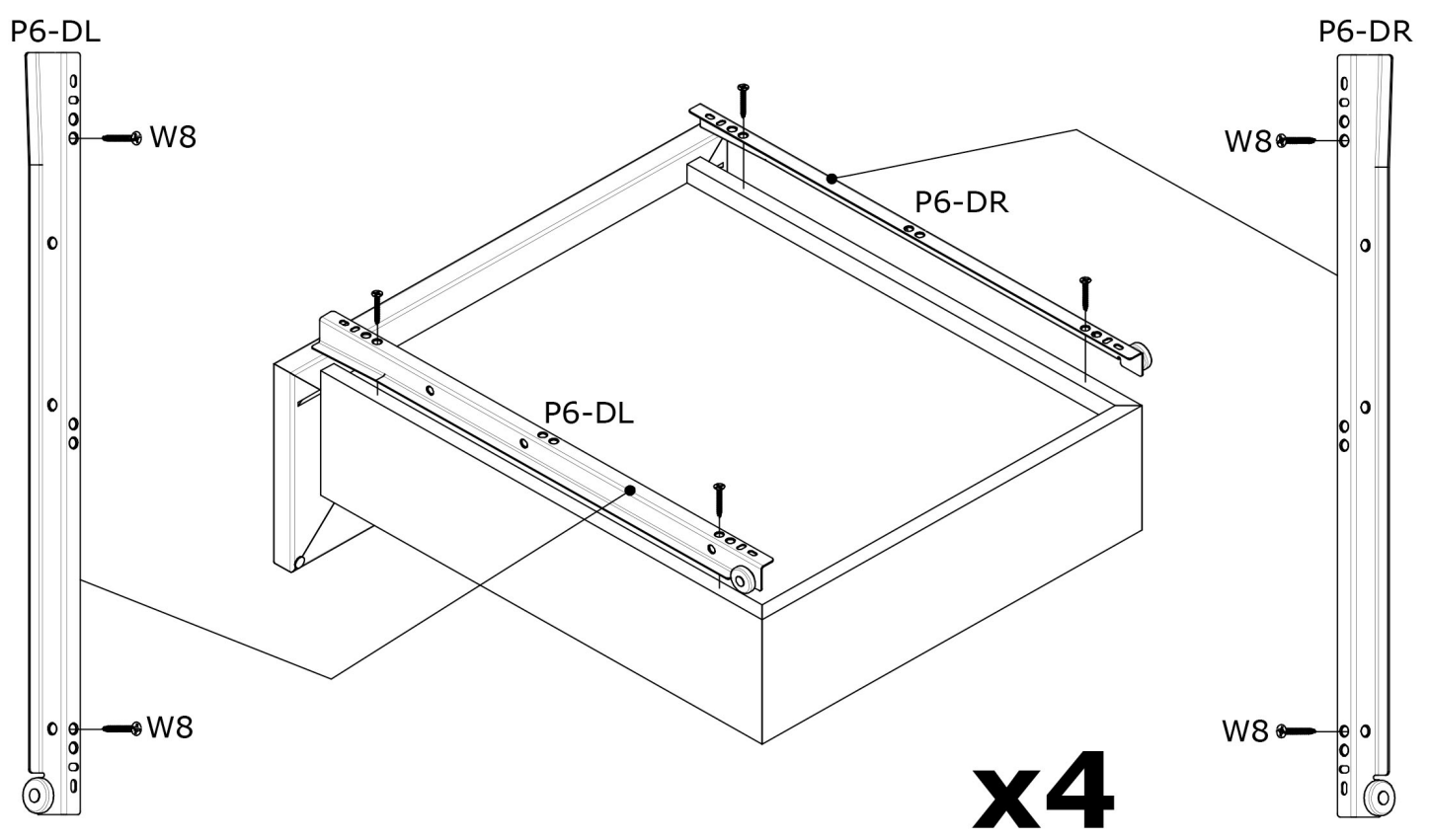
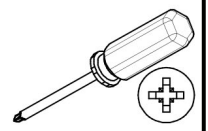
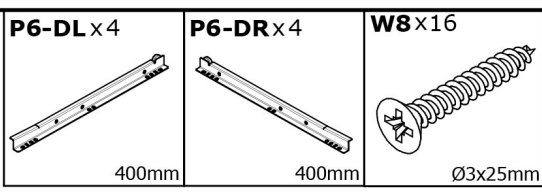

14

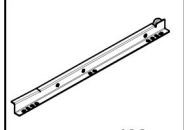

15

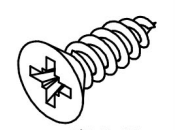
- P6-DL x1**  400mm
- P6-DR x1**  400mm
- W1 x4**  Ø3,5x13mm

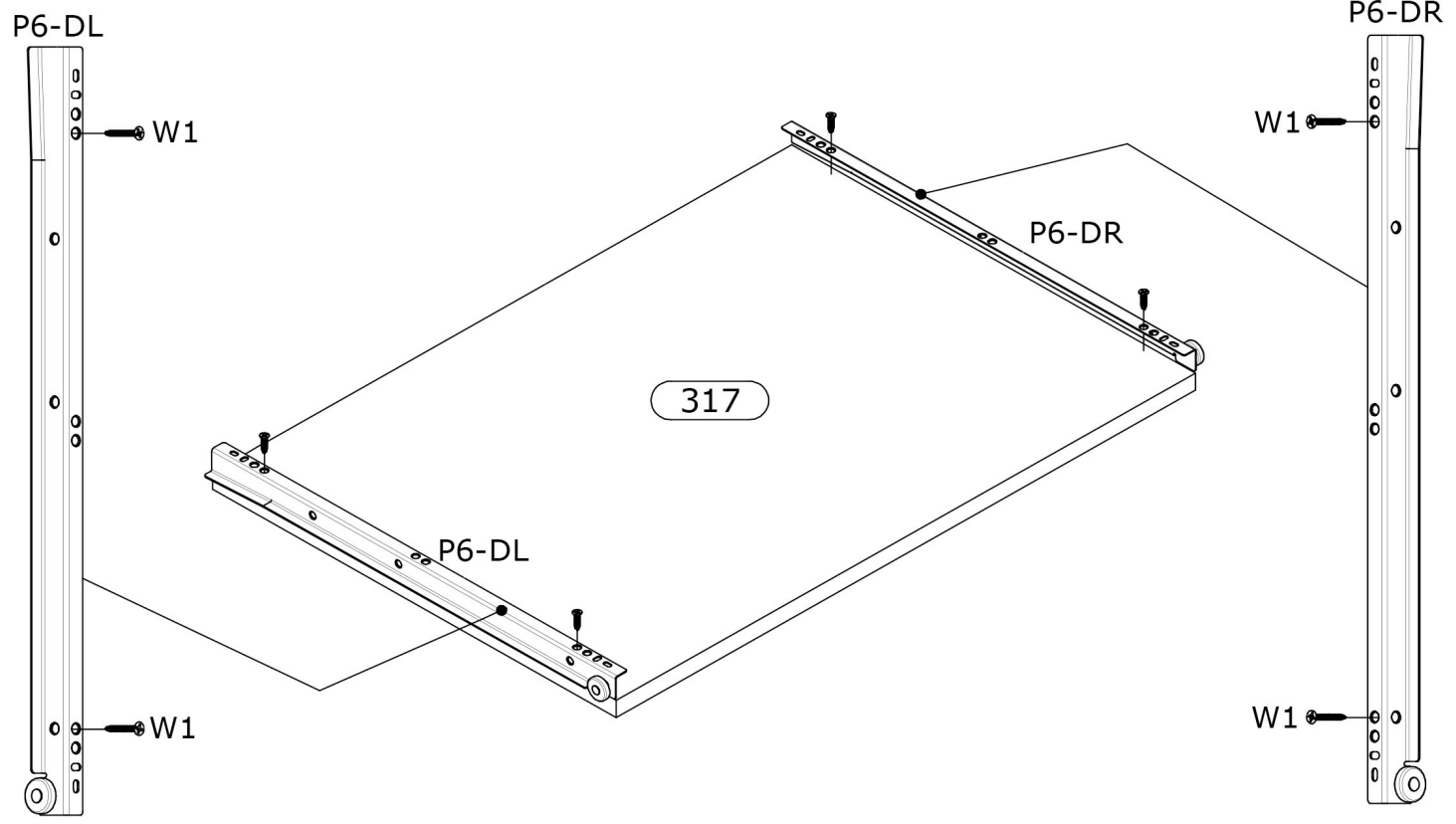
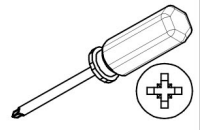

16

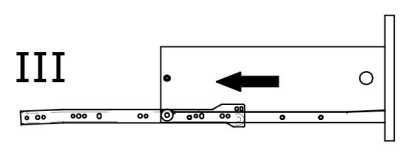
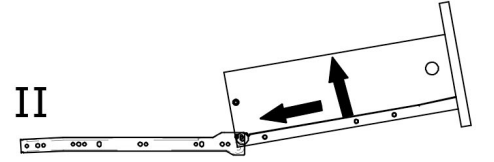
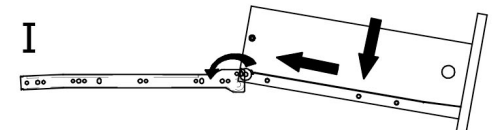
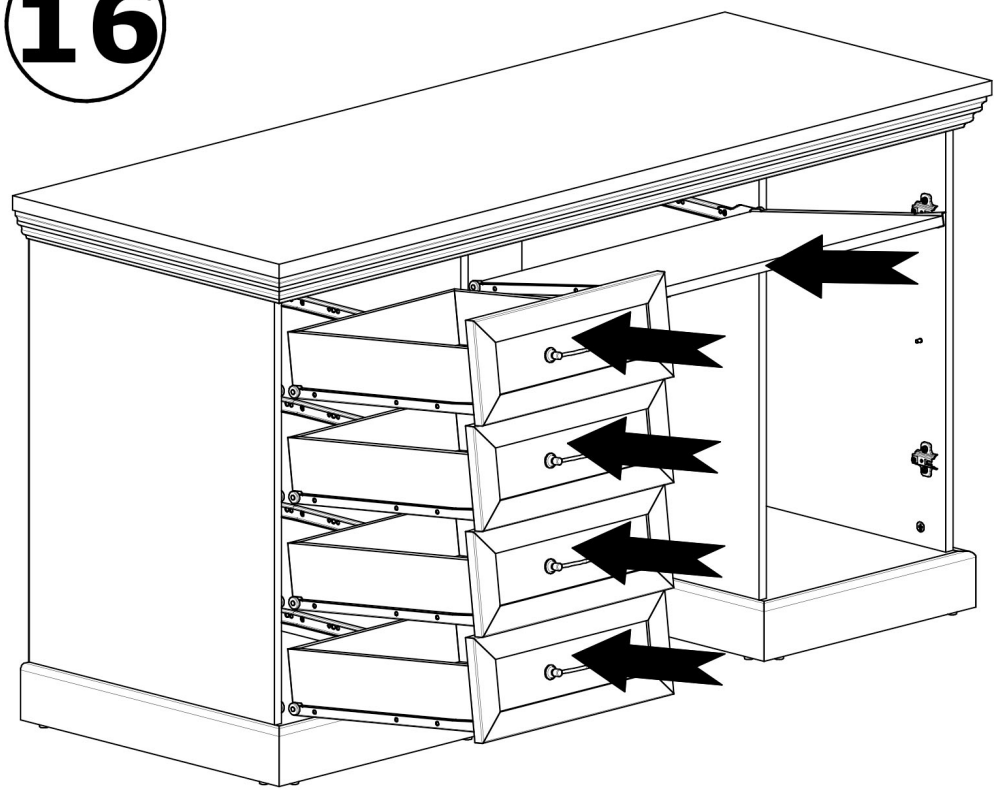

17

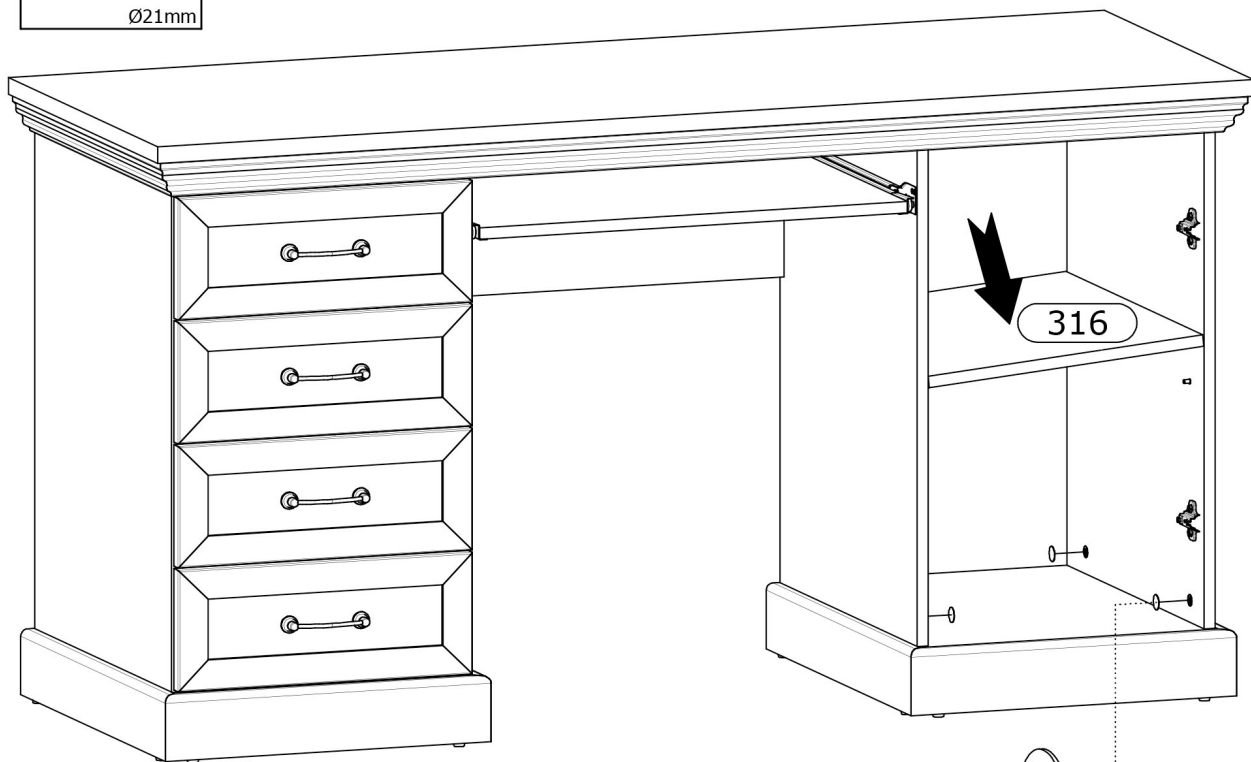
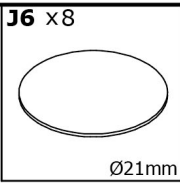

18

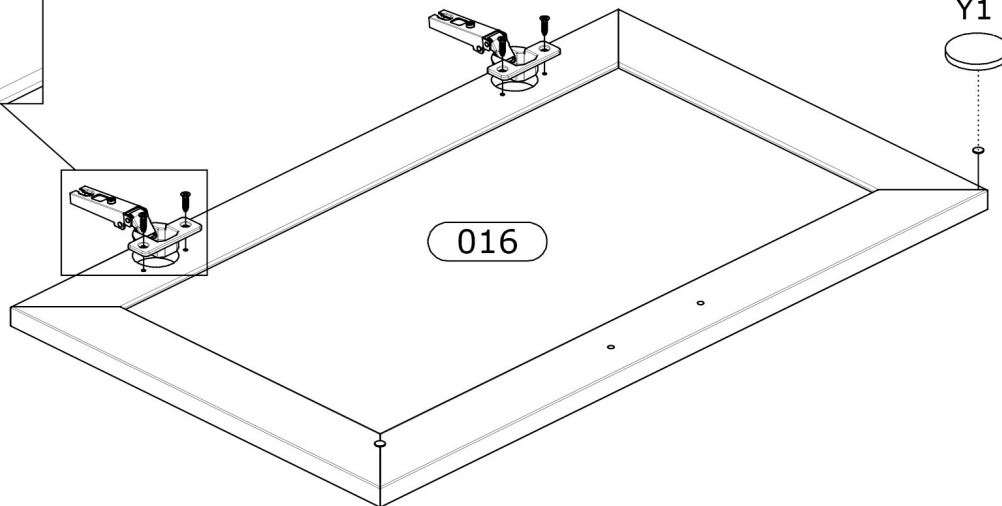
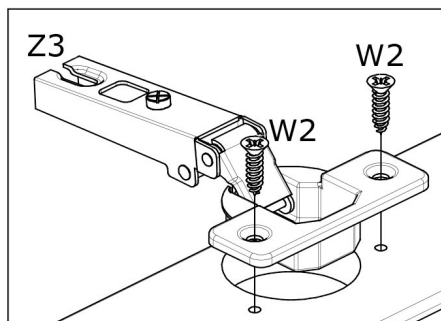
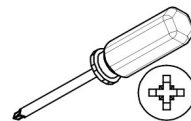
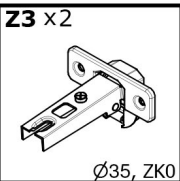
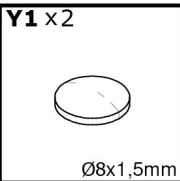
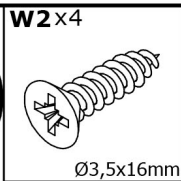

19

U7 x 1

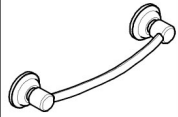

118x22mm

X3 x 2

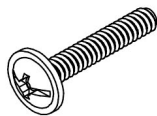

M4x22mm

