

Zahradní skleník

A101-D

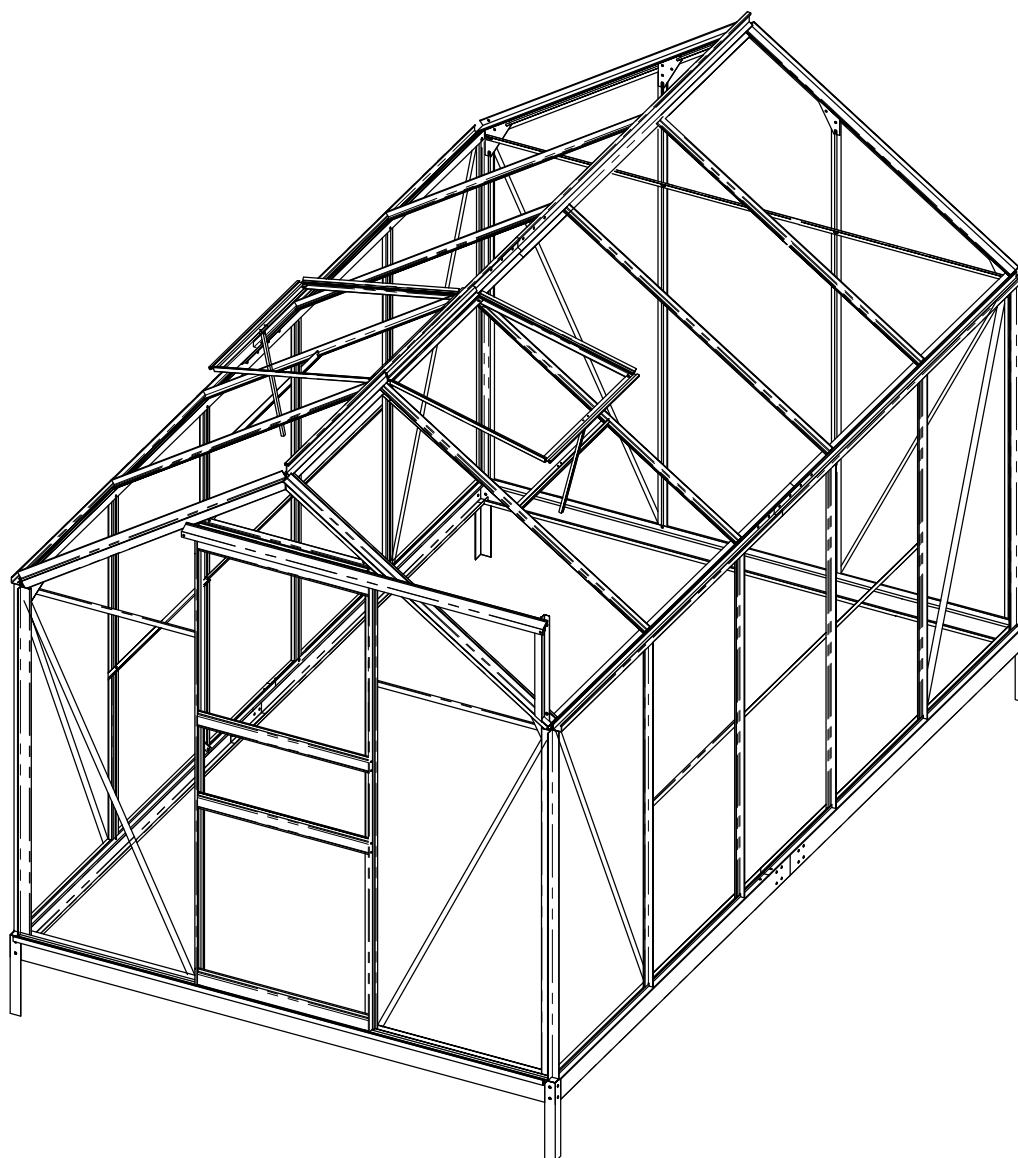

ABYSTE PŘEDEŠLI ZRANĚNÍ, PŘEČTĚTE SI PŘED POUŽITÍM NÁVOD K MONTÁŽI SKLENÍKU A POROZUMĚJTE MU.

1. Sestavení skleníku 2-3 osobami trvá přibližně 3-4 hodiny.
2. Strana fólie chráněná proti UV záření je pokryta opálově bílou fólií a musí směřovat ke slunci.
3. Před instalací odstraňte přibližně 2 cm fólie ze všech okrajů plechu.
4. Ujistěte se, že je skleník umístěn na rovném povrchu.

OBEČNÁ BEZPEČNOST, VAROVÁNÍ A BEZPEČNOSTNÍ OPATŘENÍ

UDRŽUJTE PRACOVNÍ PROSTOR ČISTÝ A SUCHÝ.

Nepořádek nebo vlhkost na pracovišti jsou rizikem úrazů.

ZŮSTAŇTE VE STŘEHU. Neustále sledujte, co děláte. Používejte zdravý rozum. Nepoužívejte skleník, když jste unavení nebo rozptýlení od práce. Při montáži skleníku se doporučuje používat rukavice.

TENTO VÝROBEK UDRŽUJTE S NÁLEŽITOU PÉČÍ.

Pro lepší výkonnost udržujte skleník v čistotě a suchu: údržbu provádějte pravidelně.

POUŽÍVEJTE SPRÁVNÝ VÝROBEK PRO DANOU PRÁCI.

Nesnažte se nutit malý výrobek, aby vykonával práci většího průmyslového výrobku. Existují určitá použití, pro která byl skleník navržen. Práci vykoná lépe a bezpečněji způsobem, pro který byl určen. Skleník neupravujte a nepoužívejte ho k účelům, pro které nebyl určen.

UDRŽUJTE BEZPEČNÉ PRACOVNÍ PROSTŘEDÍ.

Udržujte pracovní prostor v pořádku. Dbejte na to, aby byl v okolí dostatečný pracovní prostor. Vyhýbejte se místům s velkým provozem. Vždy udržujte pracovní prostor bez překážek, mastnoty, oleje, odpadků a jiných nečistot.

SPRÁVNÉ UMÍSTĚNÍ SKLENÍKU.

Ujistěte se, že je skleník umístěn na rovném povrchu.

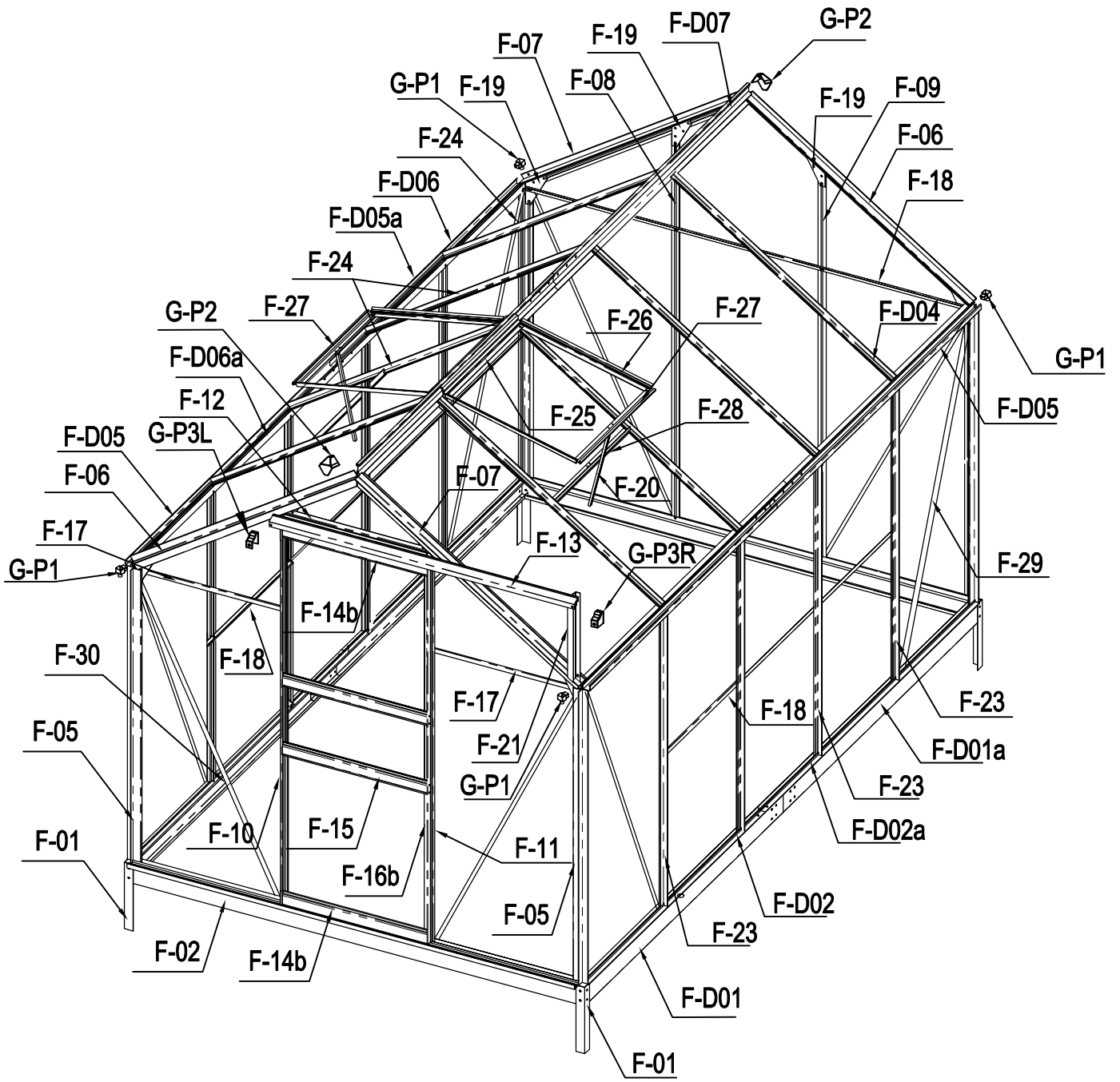

zadní

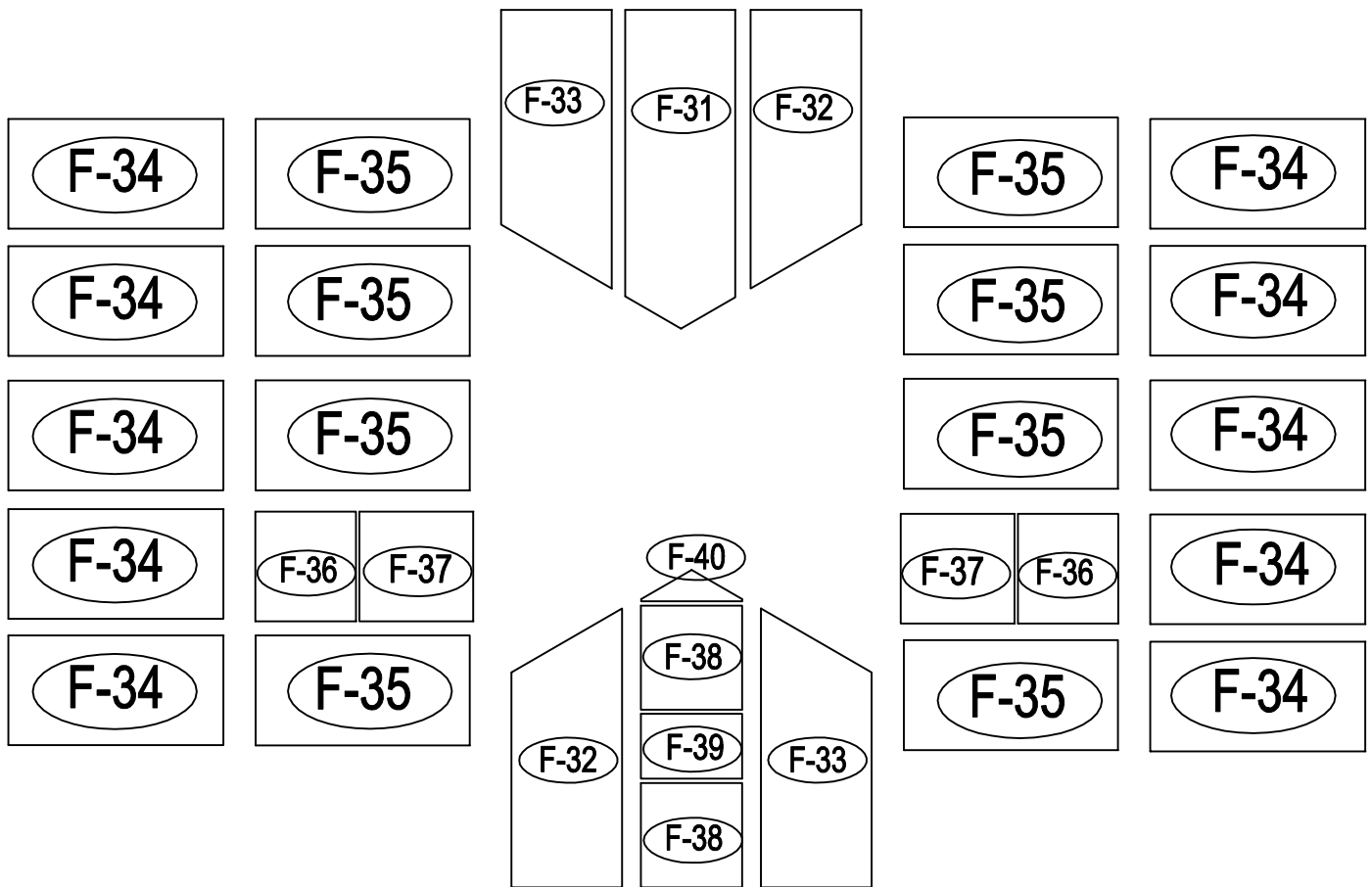

přední





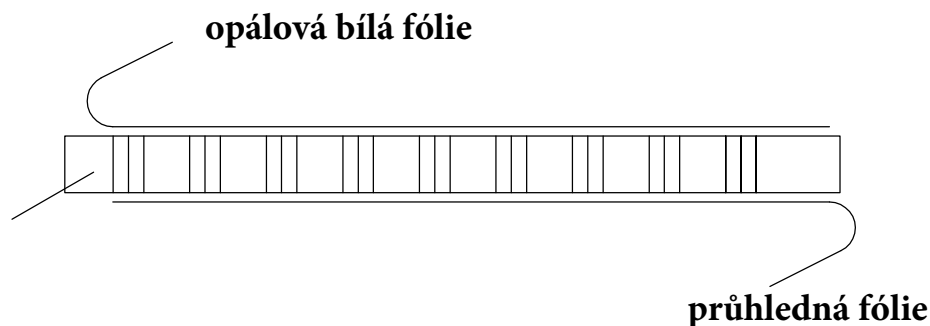









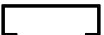

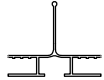

- před instalací odstraňte přibližně 5 mm fólie ze všech okrajů fólie ihned po dokončení konstrukce odstraňte veškerou fólii.
- strana fólie chráněná proti UV záření je pokryta opálově bílou fólií a musí směřovat ke slunci.

























polykarbonátový panel



- Dvě strany PC desky jsou pokryty fólií, jedna strana fólie je průhledná, druhá j opálově bílá.
- Strana desky chráněná proti UV záření je pokryta opálově bílou fólií a musí směřovat ven.

Seznam dílů

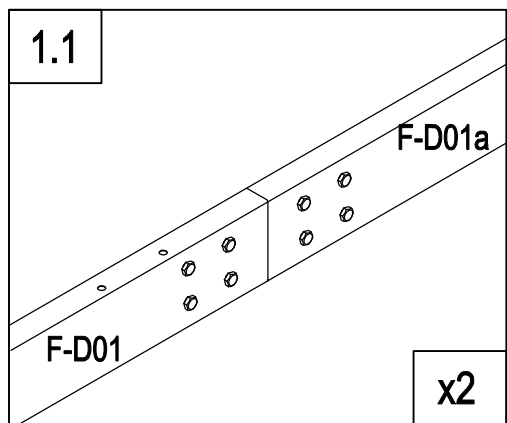
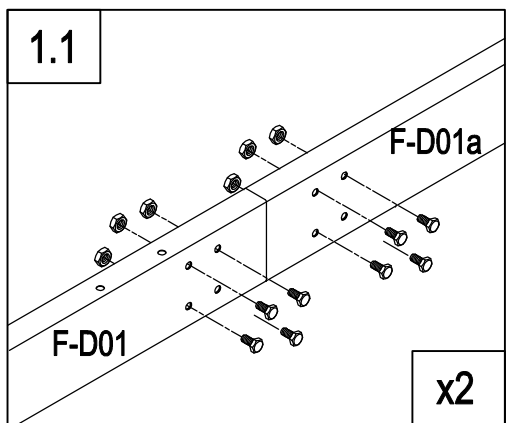
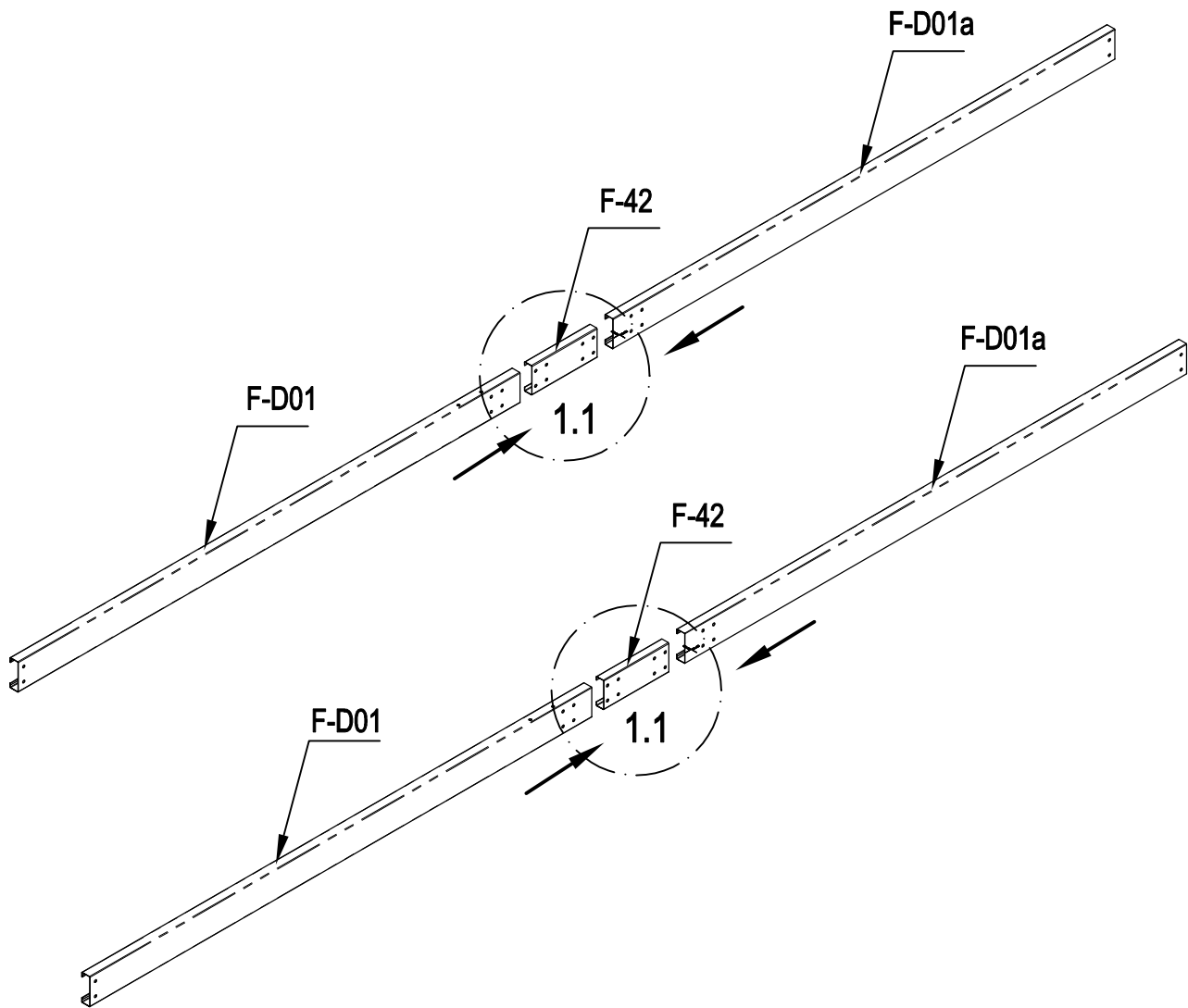

základna			
IMAGE	NO.	L.	QTY
	F-01	280	4
	F-02	1882	2
	F-D01	1541	2
	F-D01a	1541	2
	F-03b	1833	1
	F-04	1833	1
	F-D02	1370	2
	F-D02a	1662	2
	F-42	200	2
	F-D13		20
stěny a střecha			
IMAGE	NO.	L.	QTY
	F-05	1240	4
	F-06	1105	2
	F-07	1105	2
	F-08	1650	1
	F-09	1650	1
	F-23	1240	8
	F-24	1100	8
	F-10	1644	1
	F-11	1644	1
	F-D05	1586	2
	F-D05a	1450	2
	F-D06	1589	2
	F-D06a	1444	2
	F-17	618	6
	F-18	1815	3
	F-29	1360	4
	F-30	1328	4
	F-D07	1516	2
	F-31	1850x585	1
	F-32	1644x585	2
	F-33	1644x585	2
	F-34	1238x585	10
	F-35	1110x585	8
	F-36	540x585	2
	F-40		1

	F-19		8
	F-43	390	2
okno			
IMAGE	NO.	L.	QTY
	F-20	360	2
	F-25	580	2
	F-26	550	4
	F-27	580	2
	F-28	620	2
	F-37	577x583	2
dveře			
IMAGE	NO.	L.	QTY
	F-12	572.5	1
	F-13	1240	1
	F-14b	600	2
	F-15	600	2
	F-16b	1615	2
	F-21	376	1
	F-22b		4
	F-38	590x598	2
	F-39	251x598	1
plast			
IMAGE	NO.	L.	QTY
	G-P1		4
	G-P2		2
	G-P3L		1
	G-P3R		1
šrouby			
IMAGE	NO.	L.	QTY
	F-D14		190
ST4x10 	F-D15a		16
ST4x8 	F-D16		8



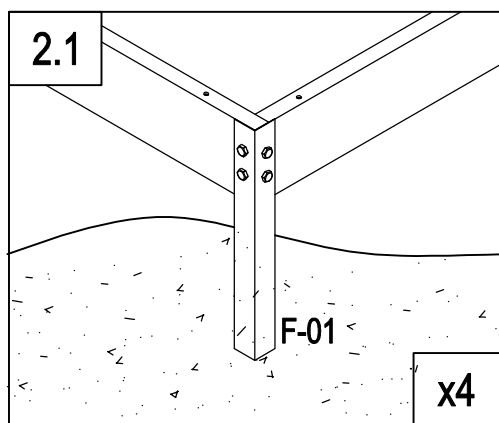
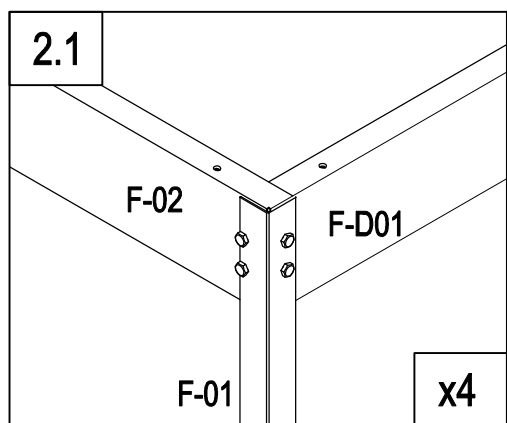
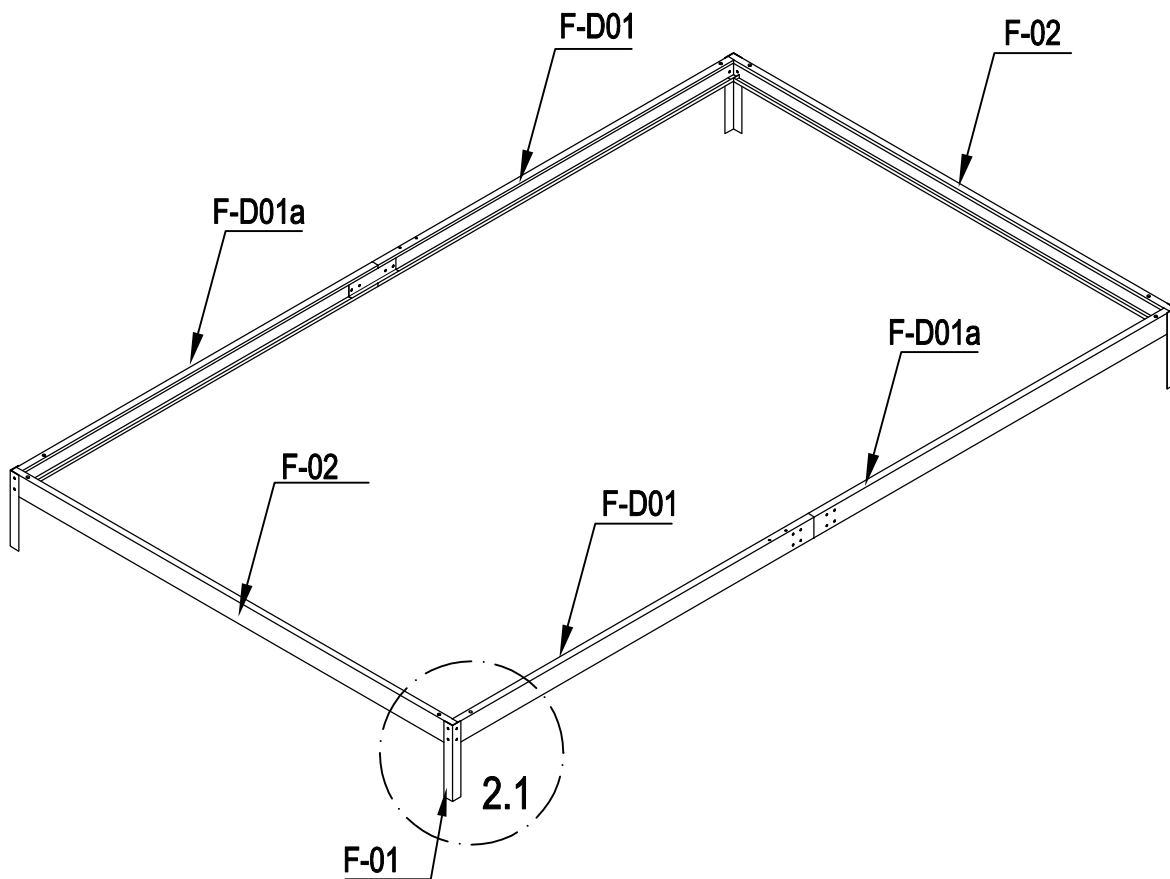

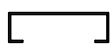

	F-D01	2
	F-D01a	2
	F-42	2
	F-D14	16

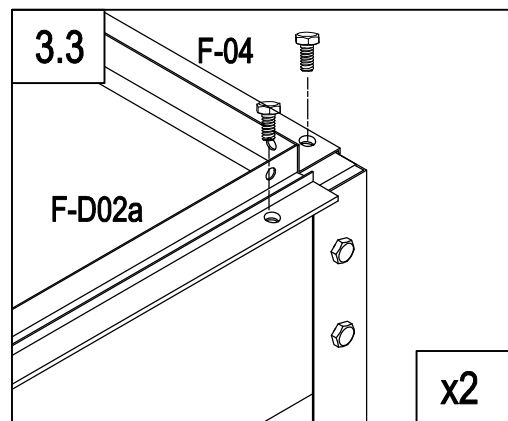
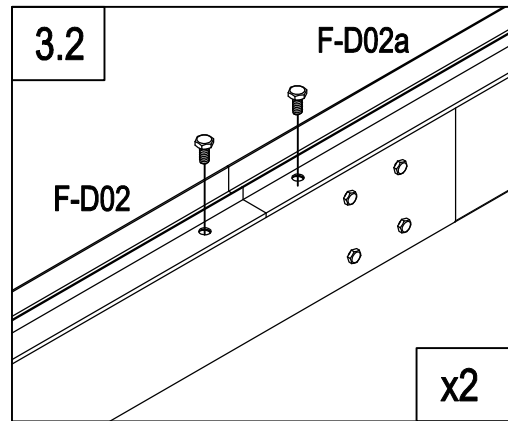
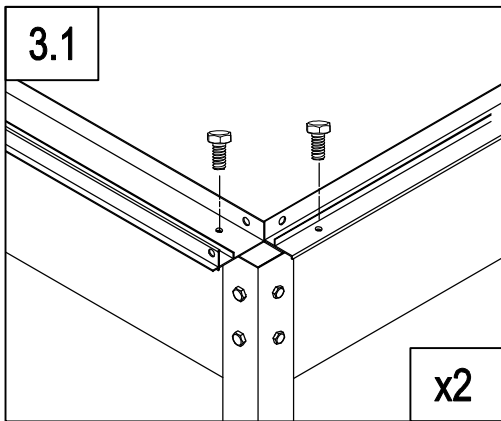
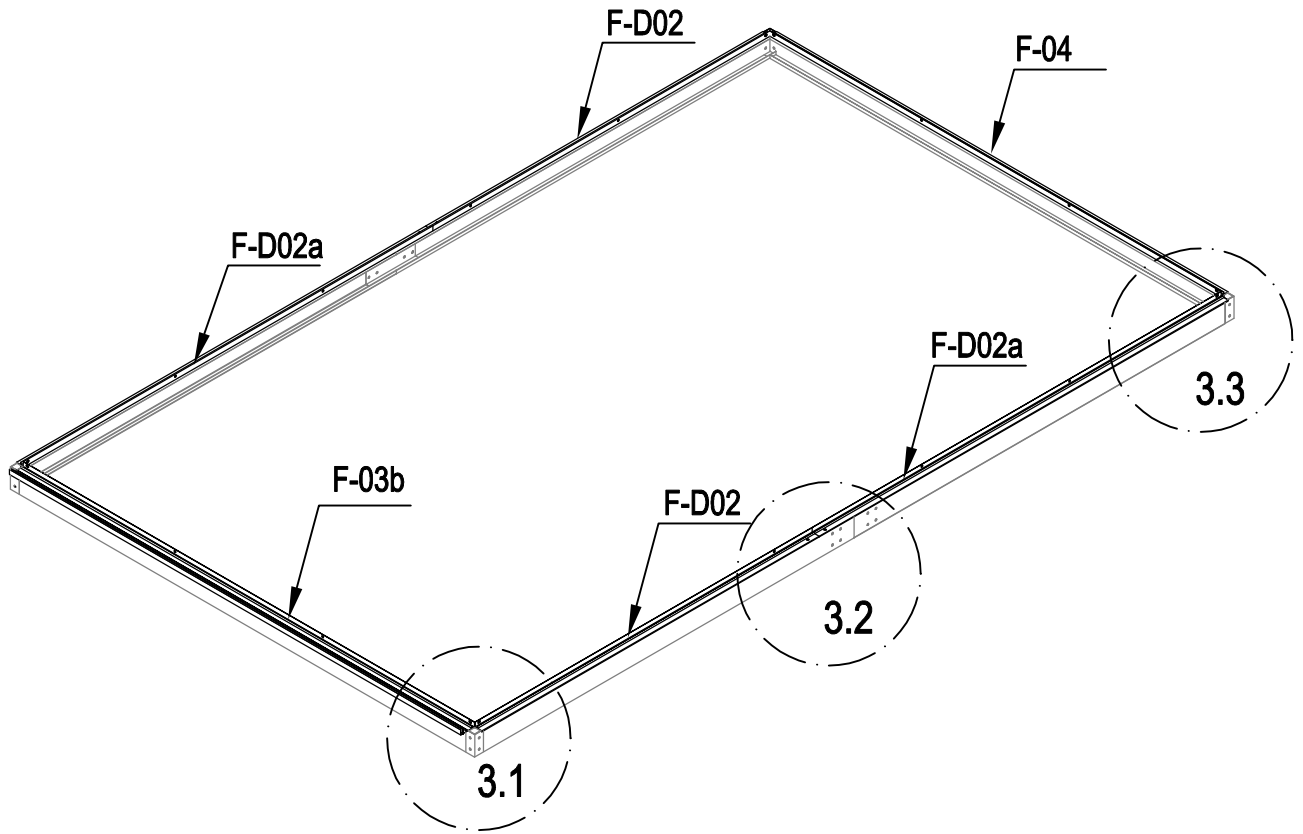



	F-02	2
	F-01	4
	F-D14	16



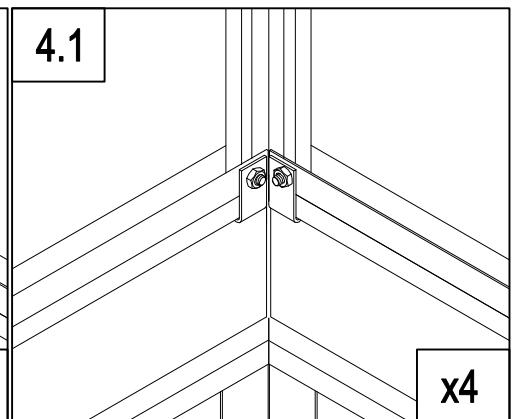
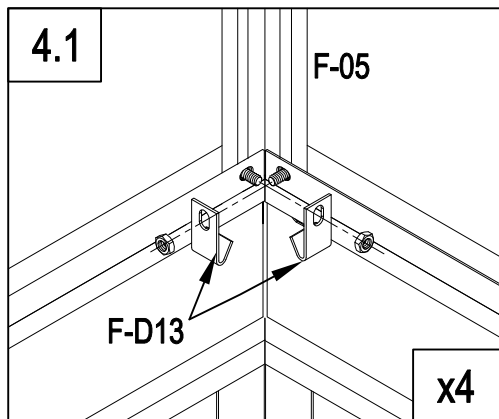
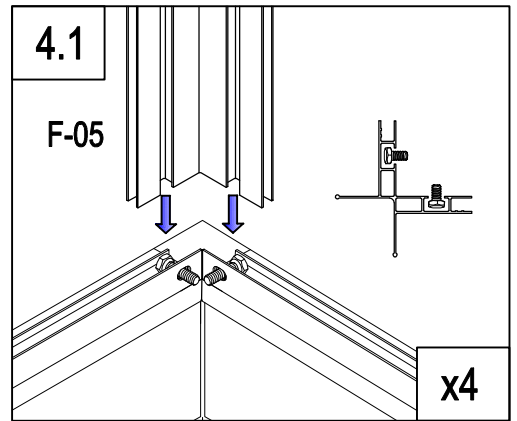
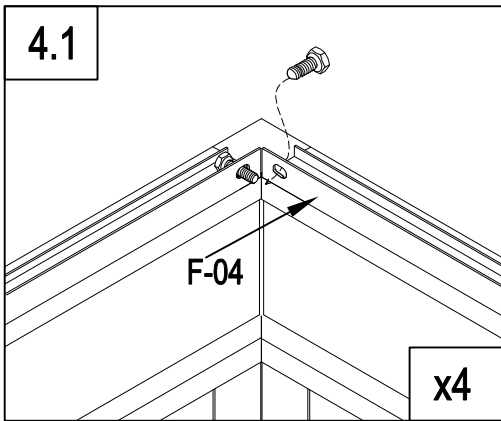
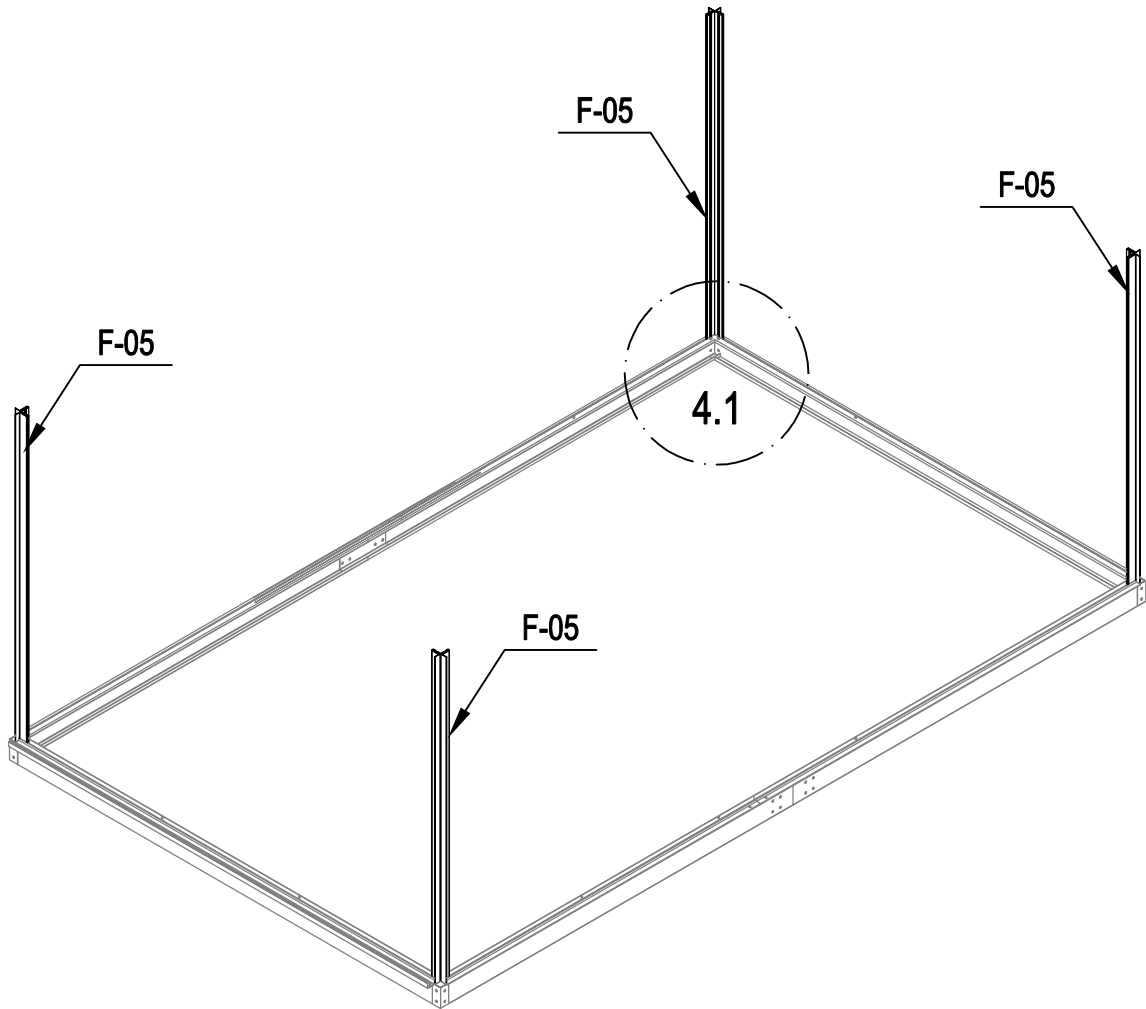

	F-D02	2
	F-D02a	2
	F-04	1
	F-03b	1
	F-D14	12

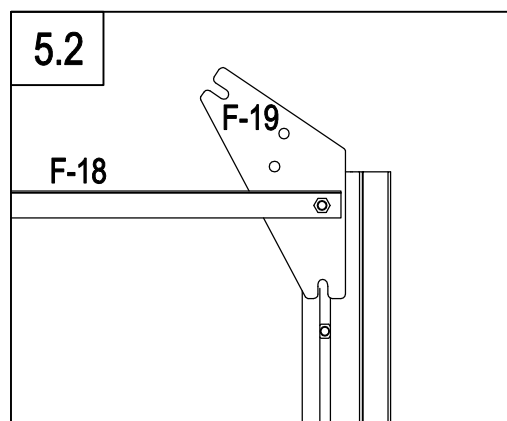
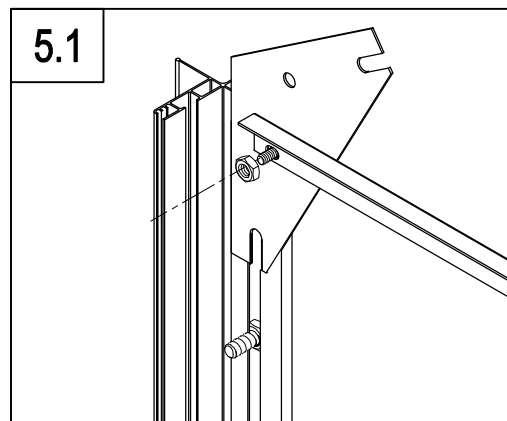
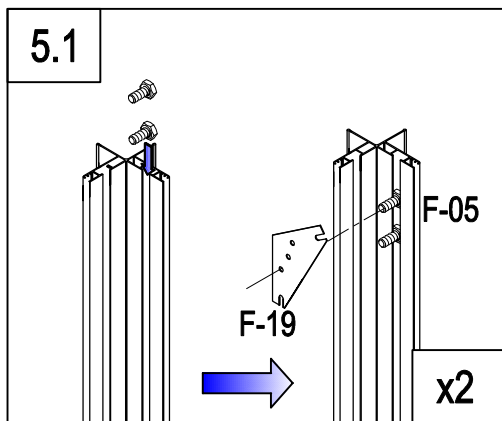
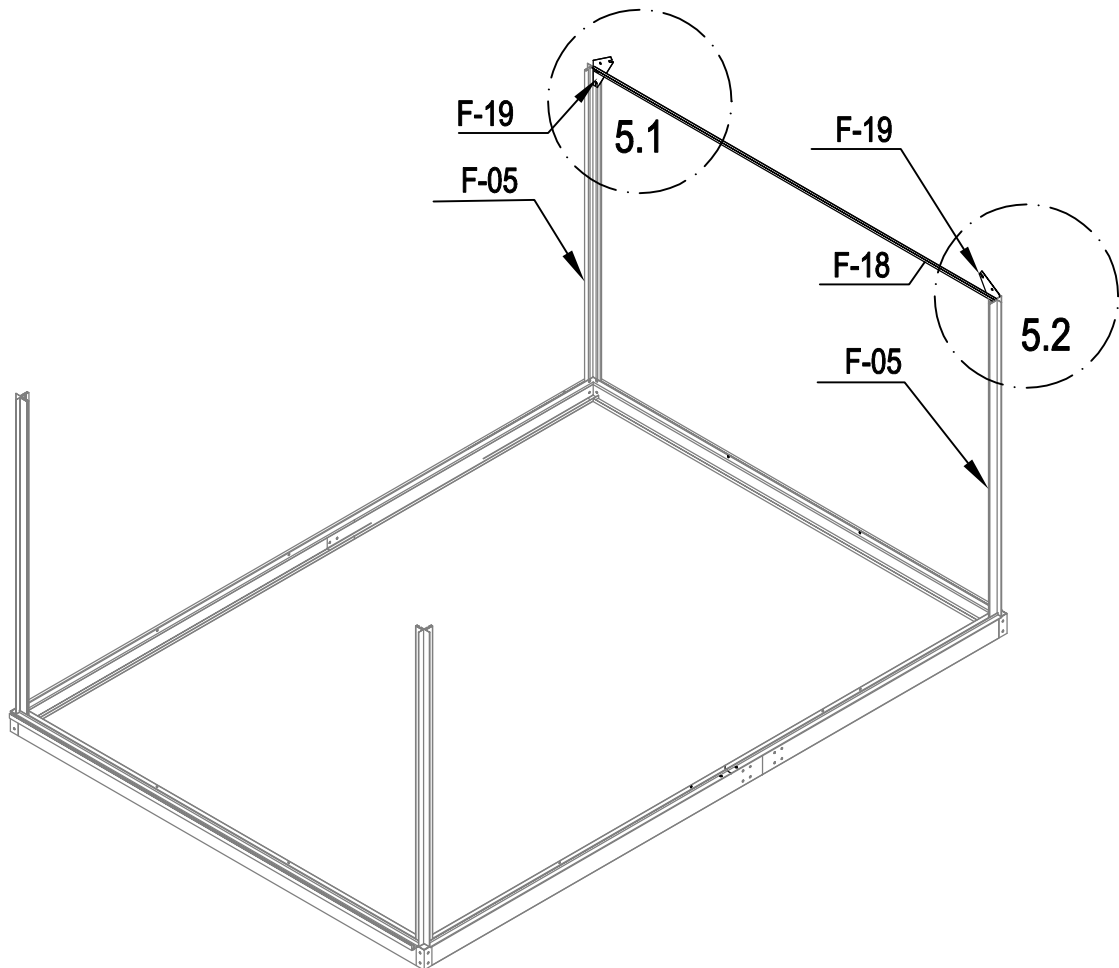

	F-05	4
	F-D13	8
	F-D14	8

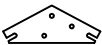



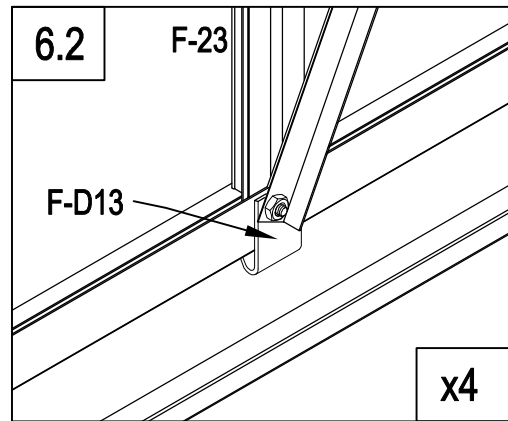
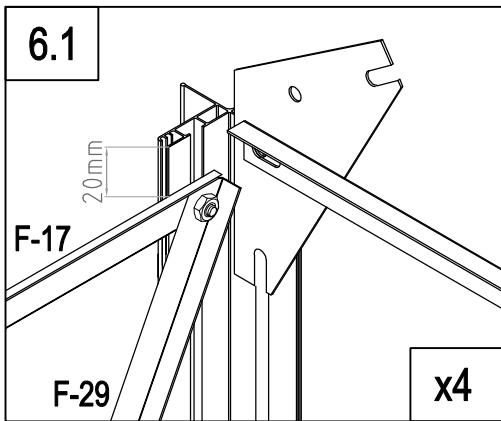
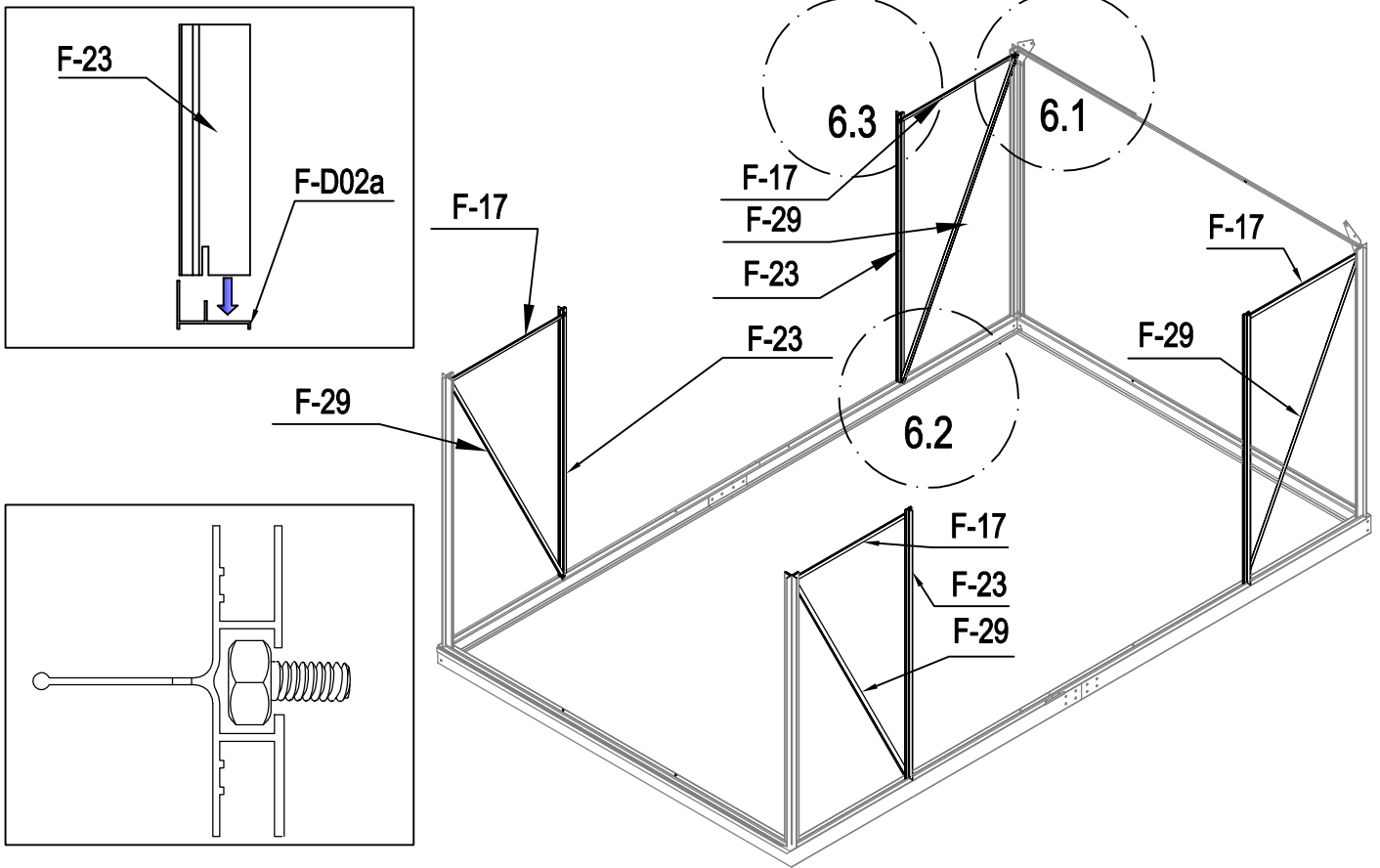

	F-18	1
	F-19	2
	F-D14	4

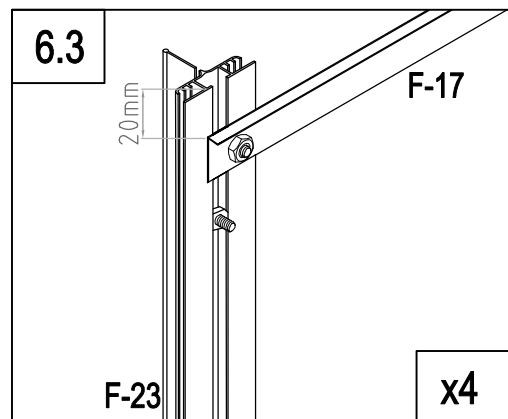

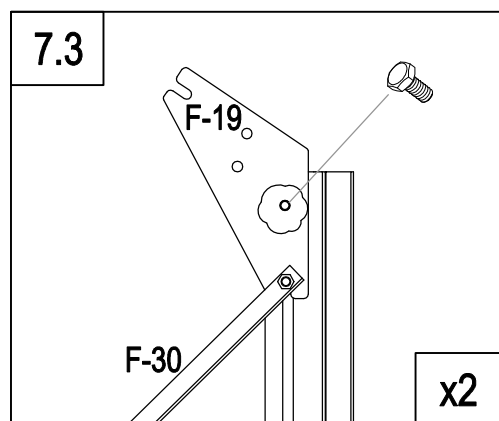
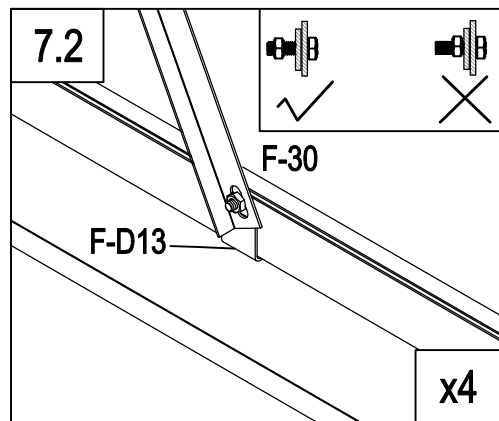
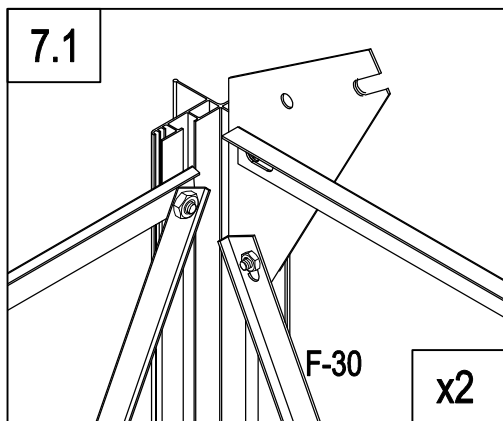
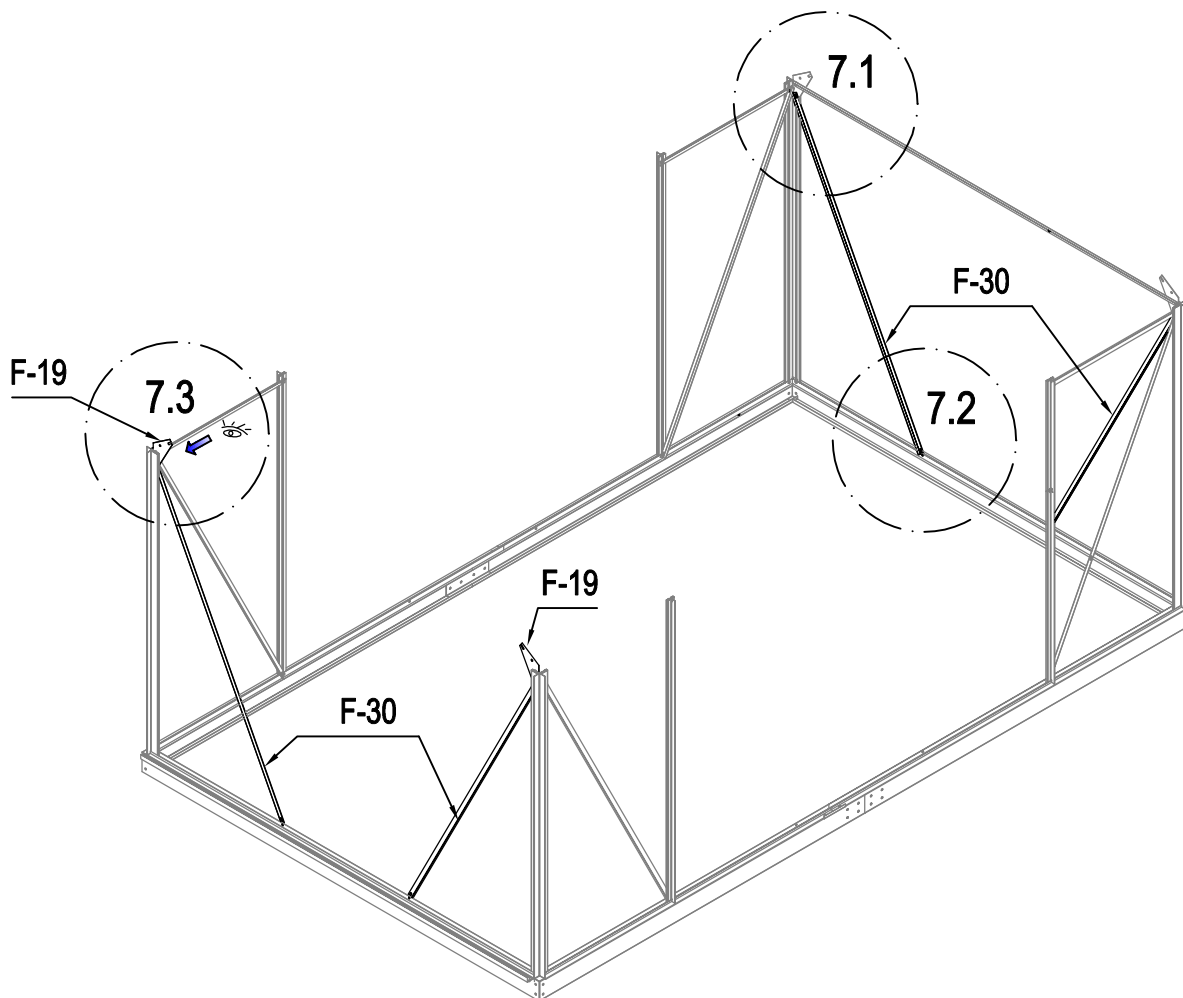

	F-D13	4
	F-17	4
	F-23	4
	F-29	4
	F-D14	16
	F-D14	12

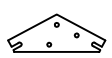

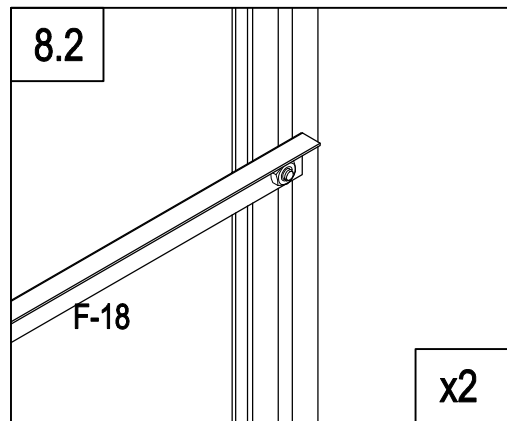
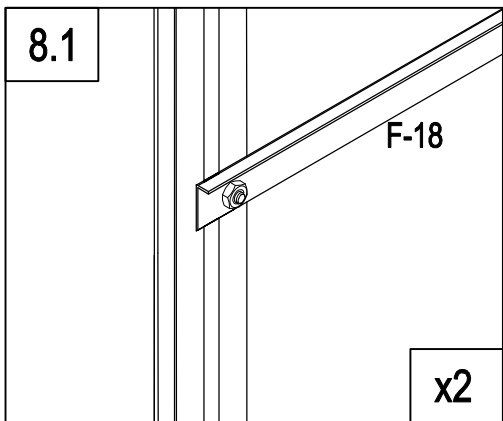
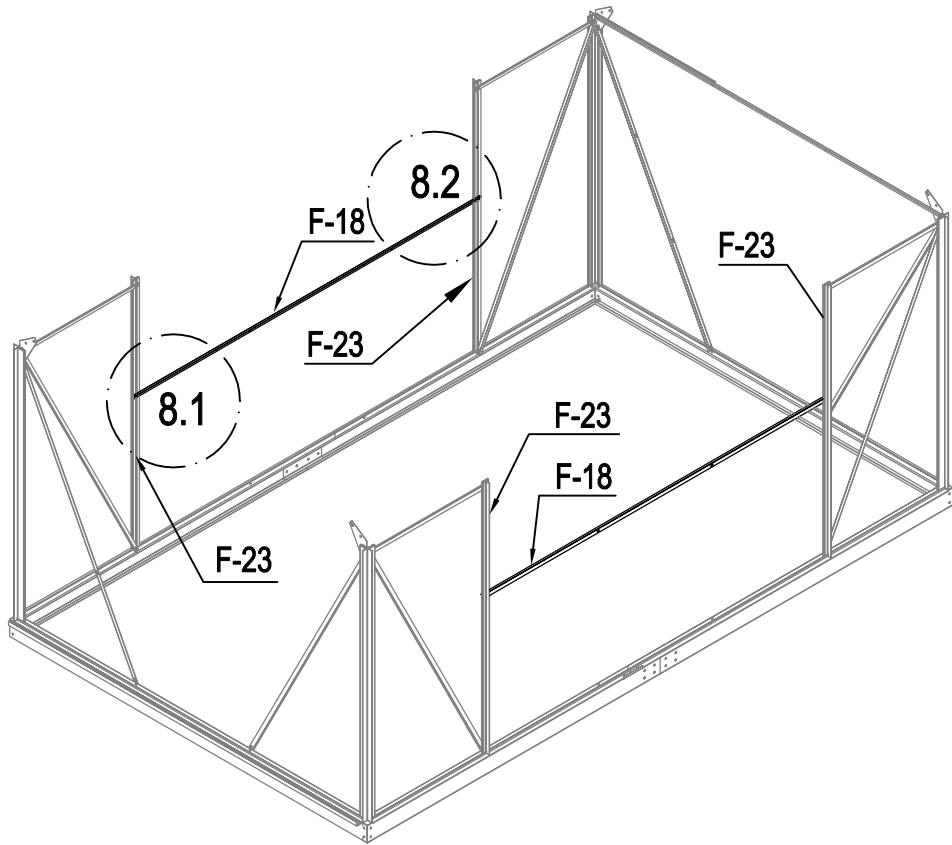

	F-D13	4
	F-30	4
	F-19	2
	F-D14	8



	F-18	2
	F-D14	4

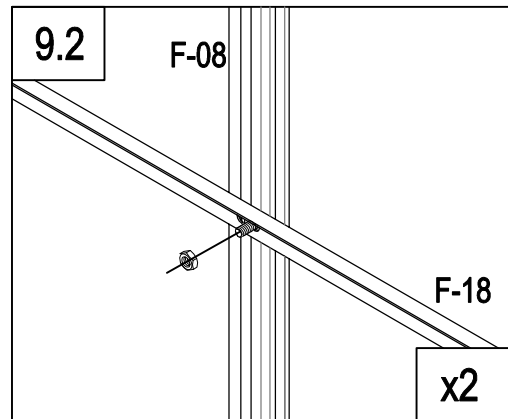
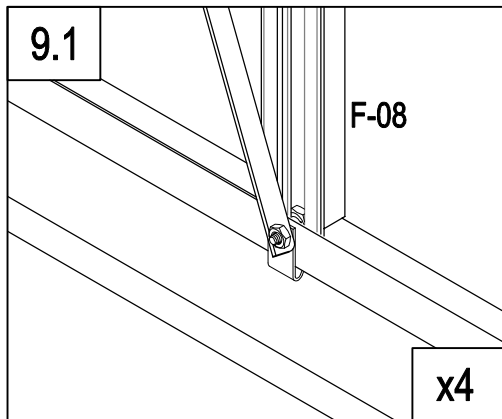
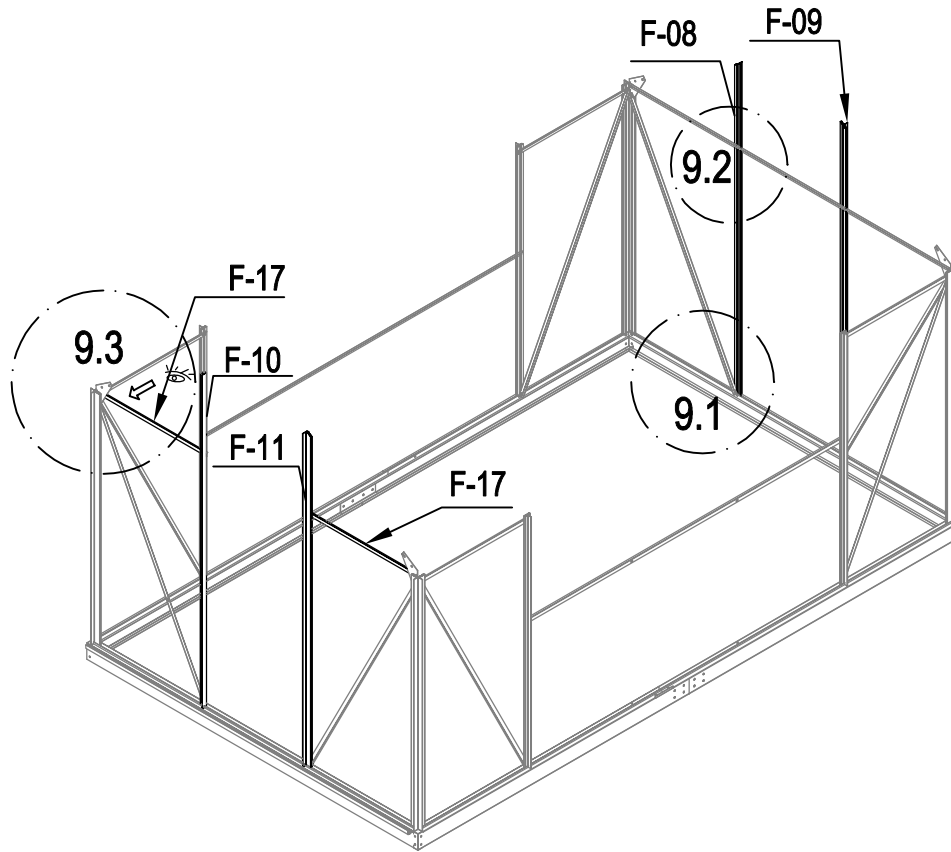



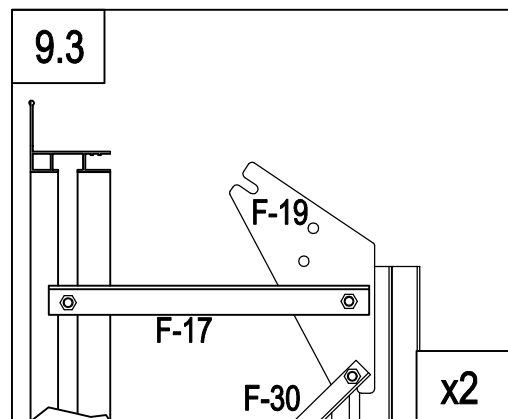

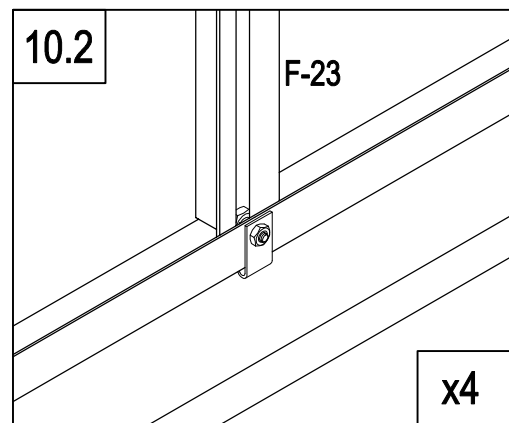
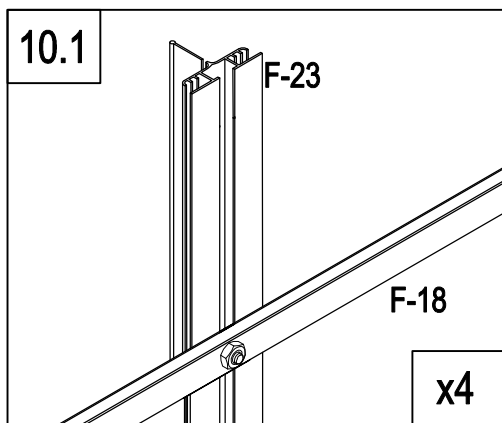
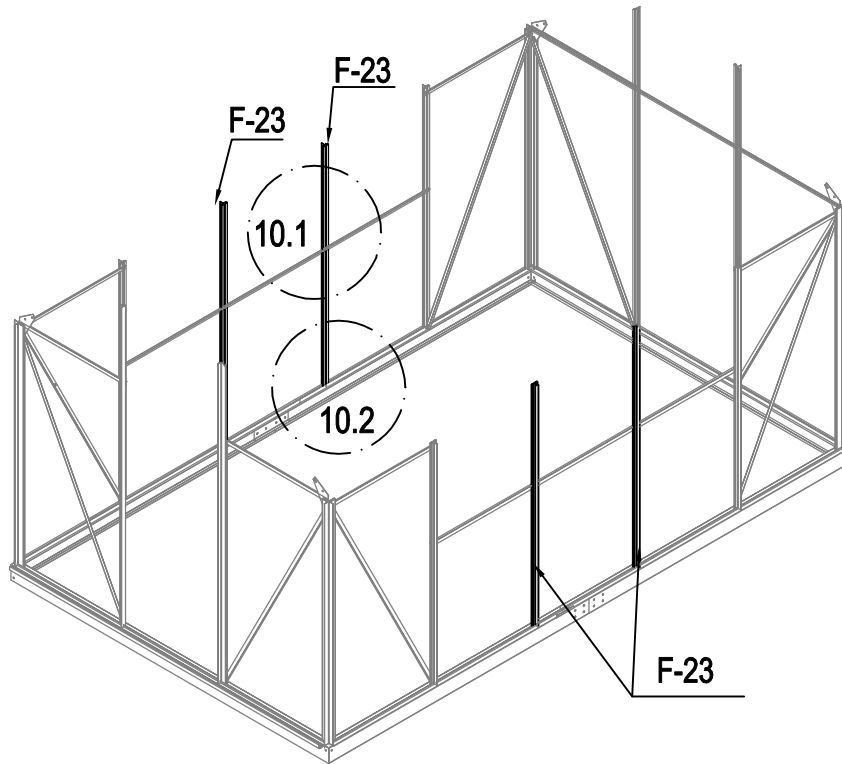
	F-08	1
	F-09	1
	F-10	1
	F-11	1
	F-17	2
	F-D14	4



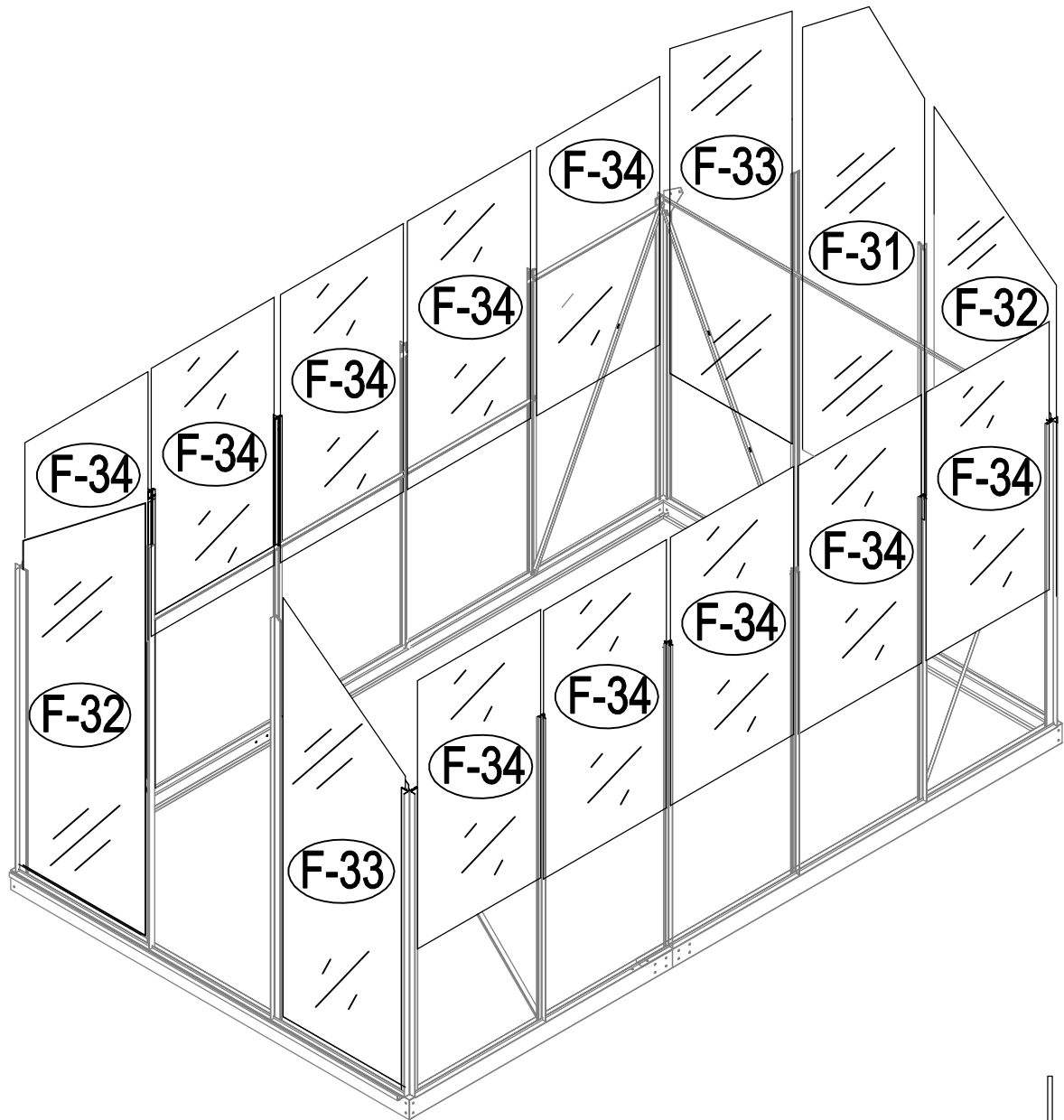

	F-D13	4
	F-23	4
	F-D14	8



	F-31	1
	F-32	2
	F-33	2
	F-34	10

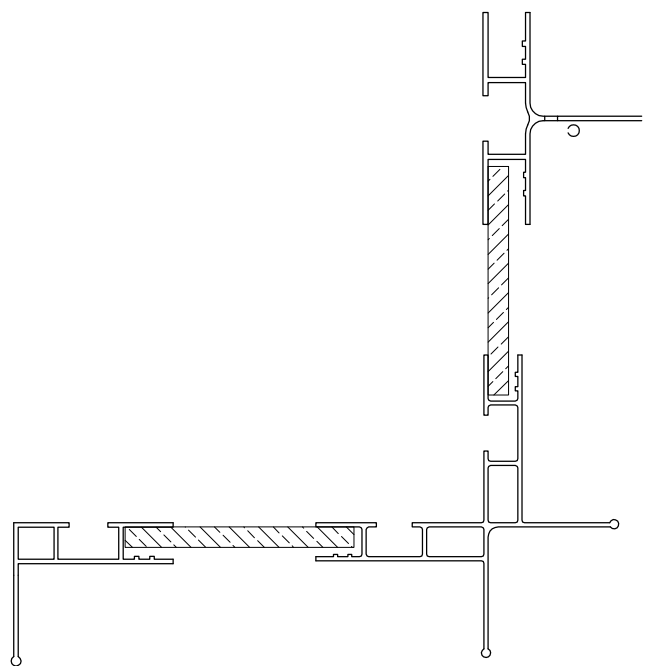

11

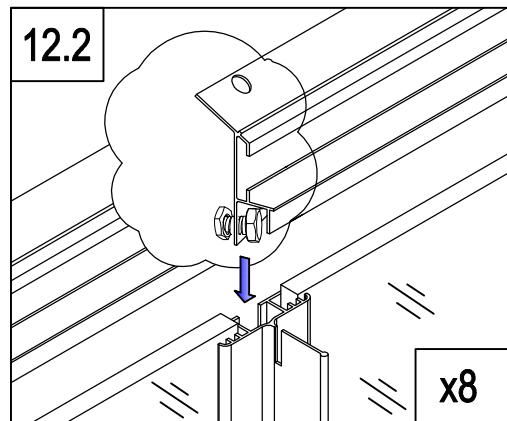
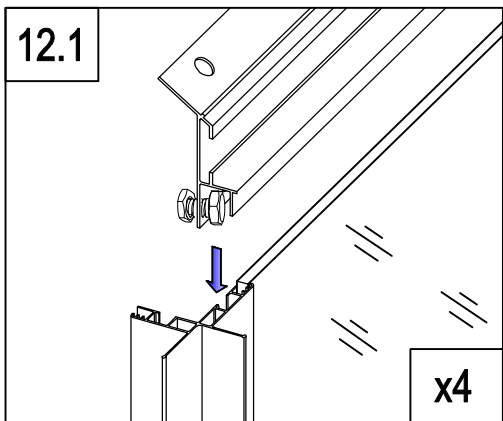
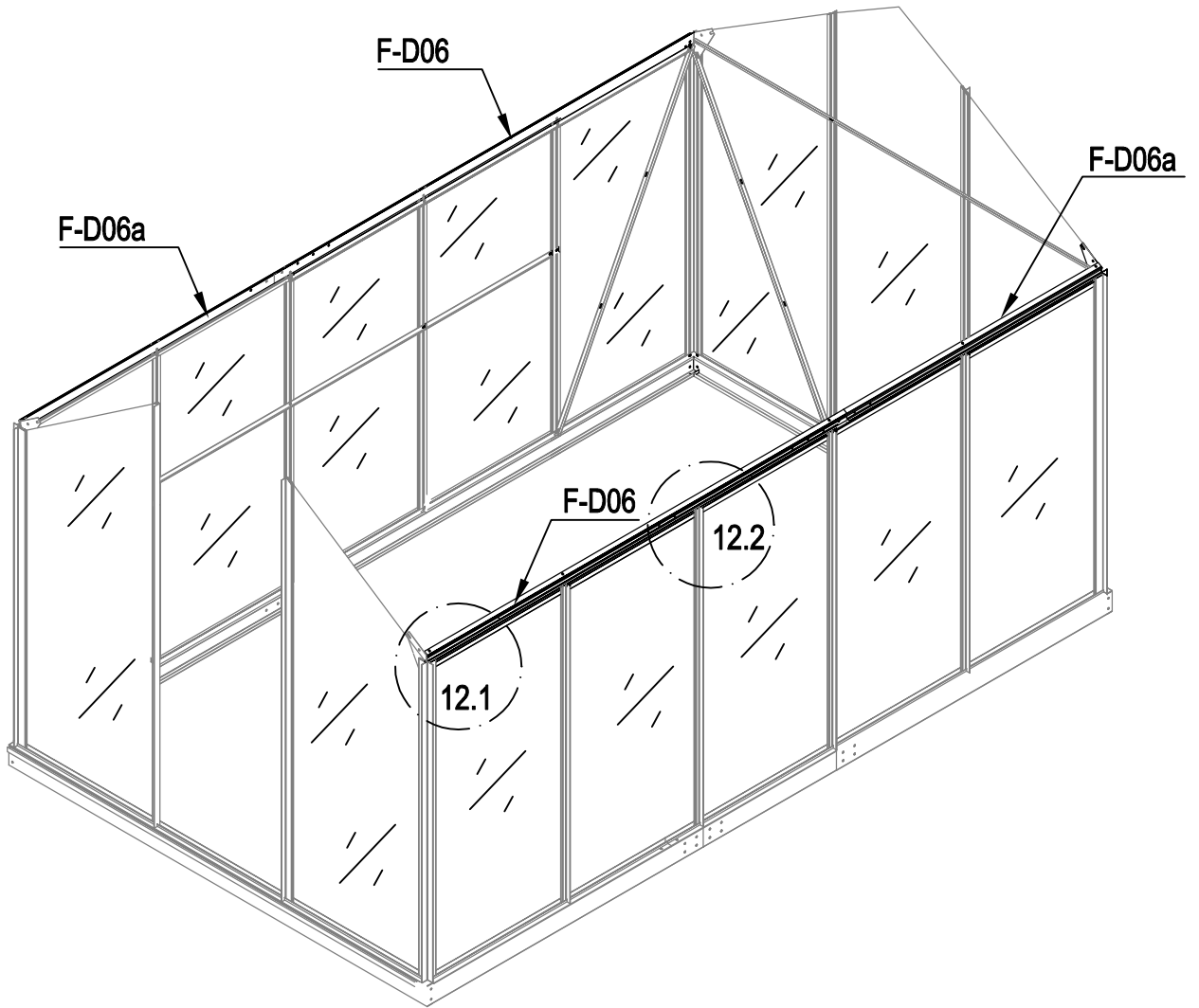

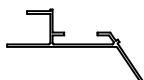
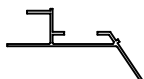
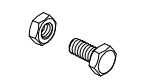
	F-D06	2
	F-D06a	2
	F-D14	12

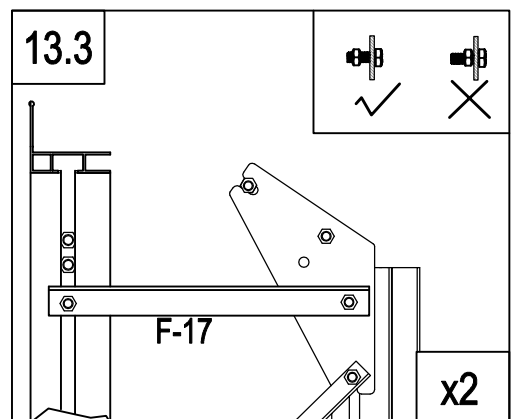
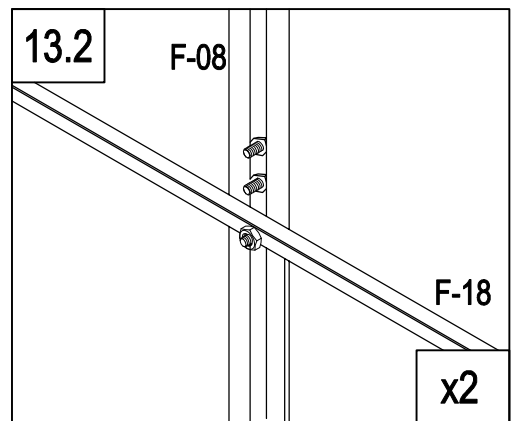
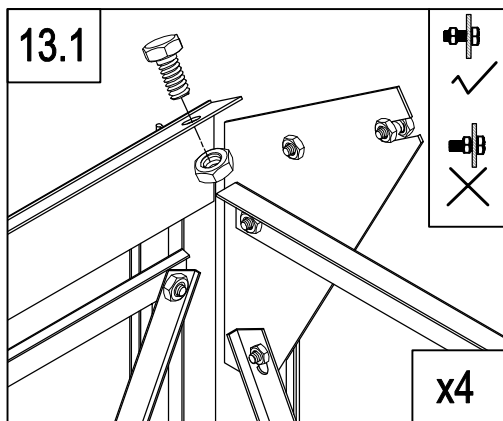
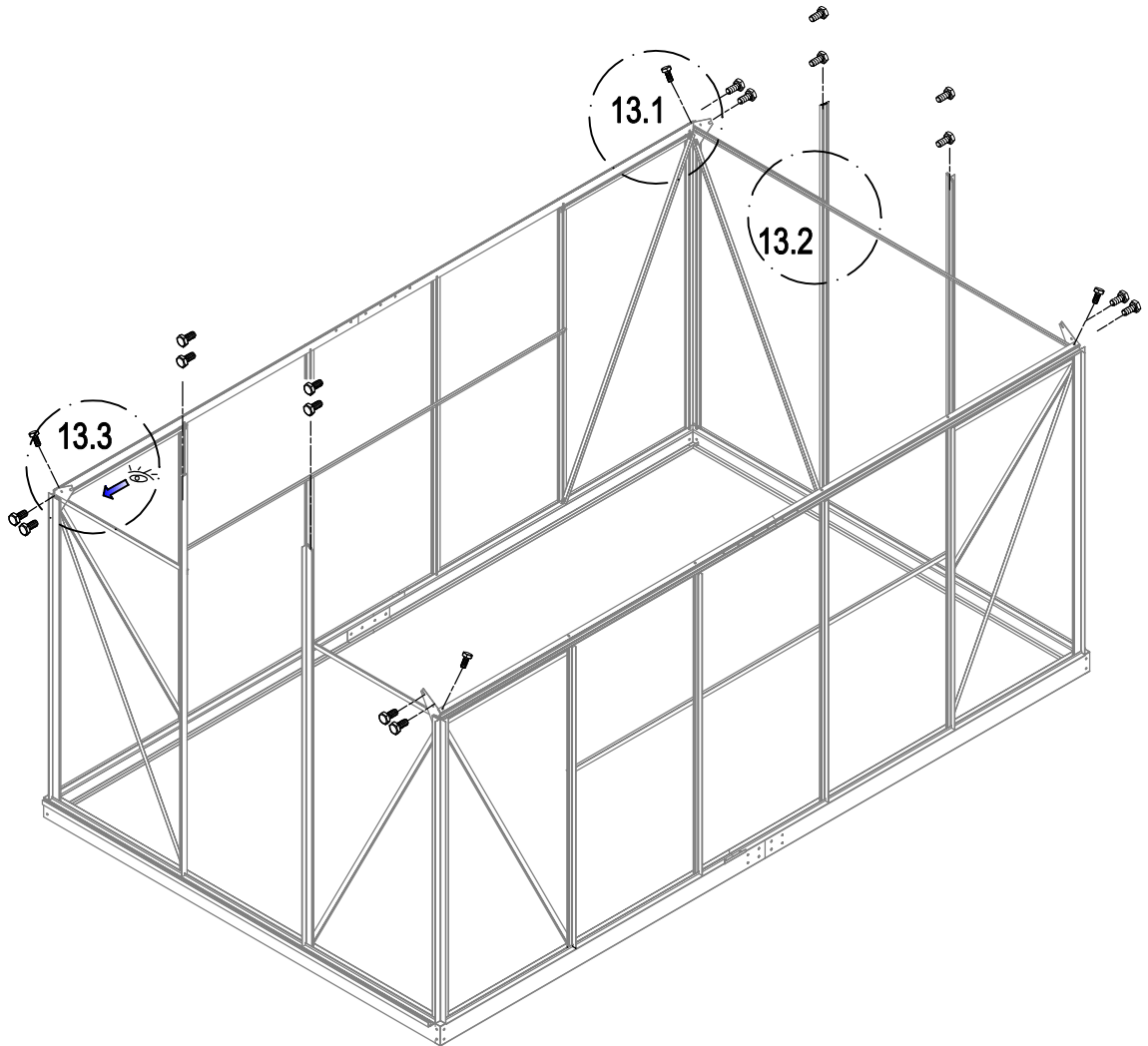

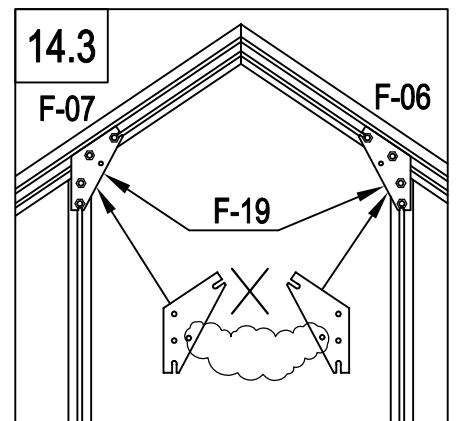
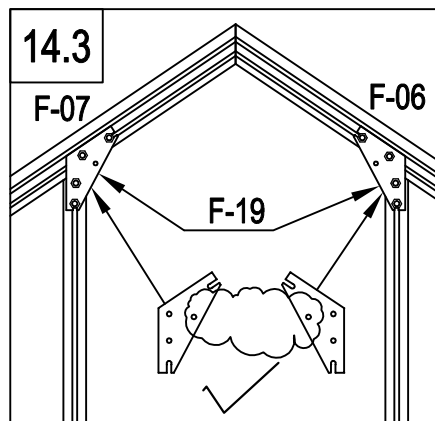
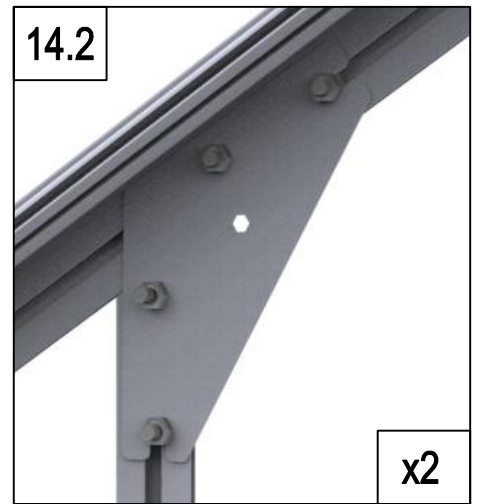
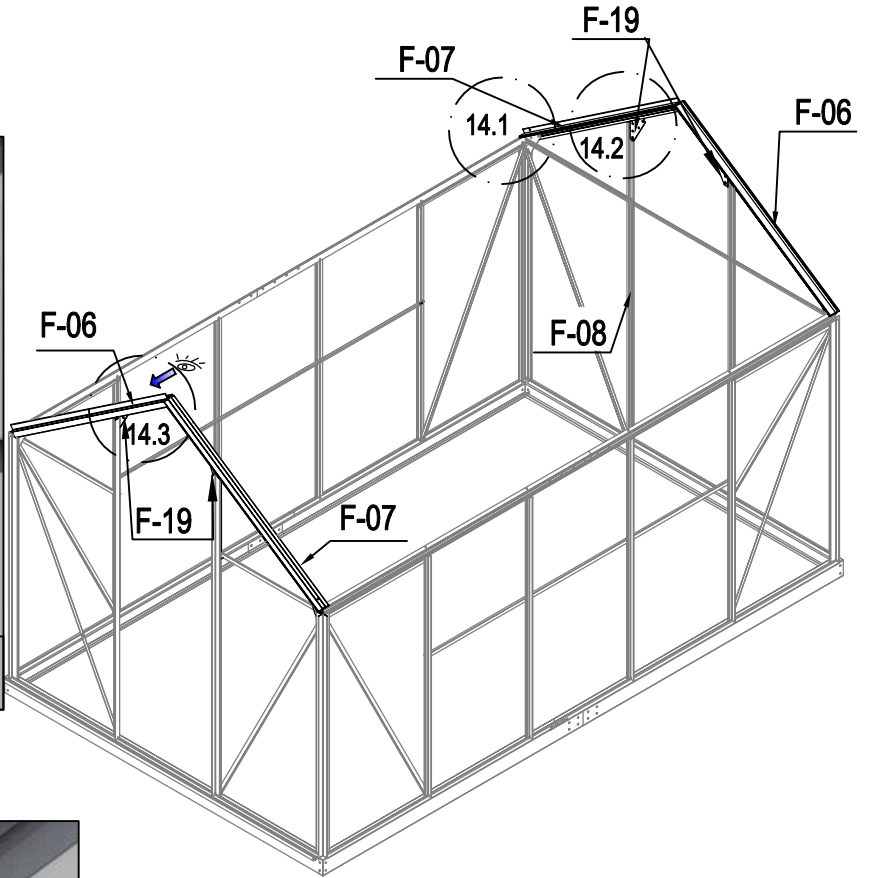
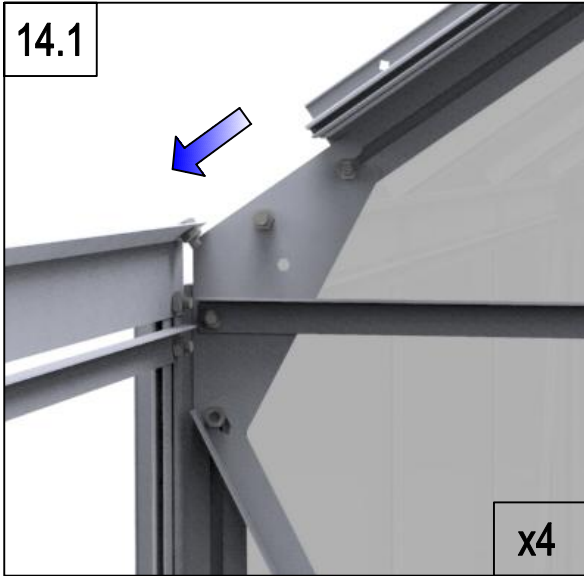

	F-D14	20
---	-------	----



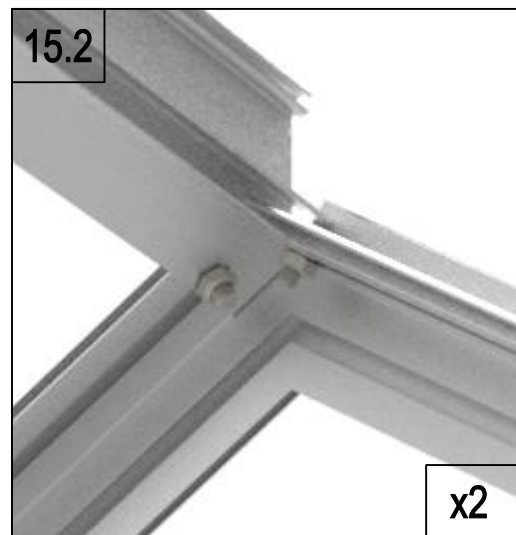
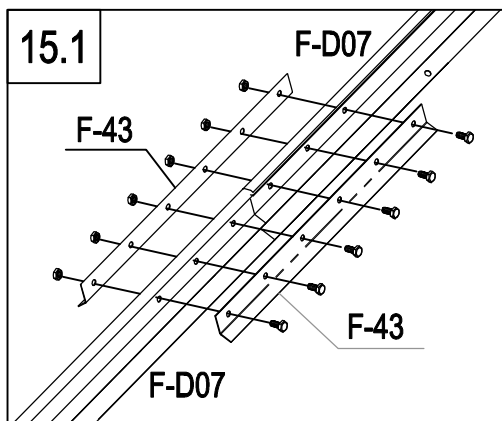
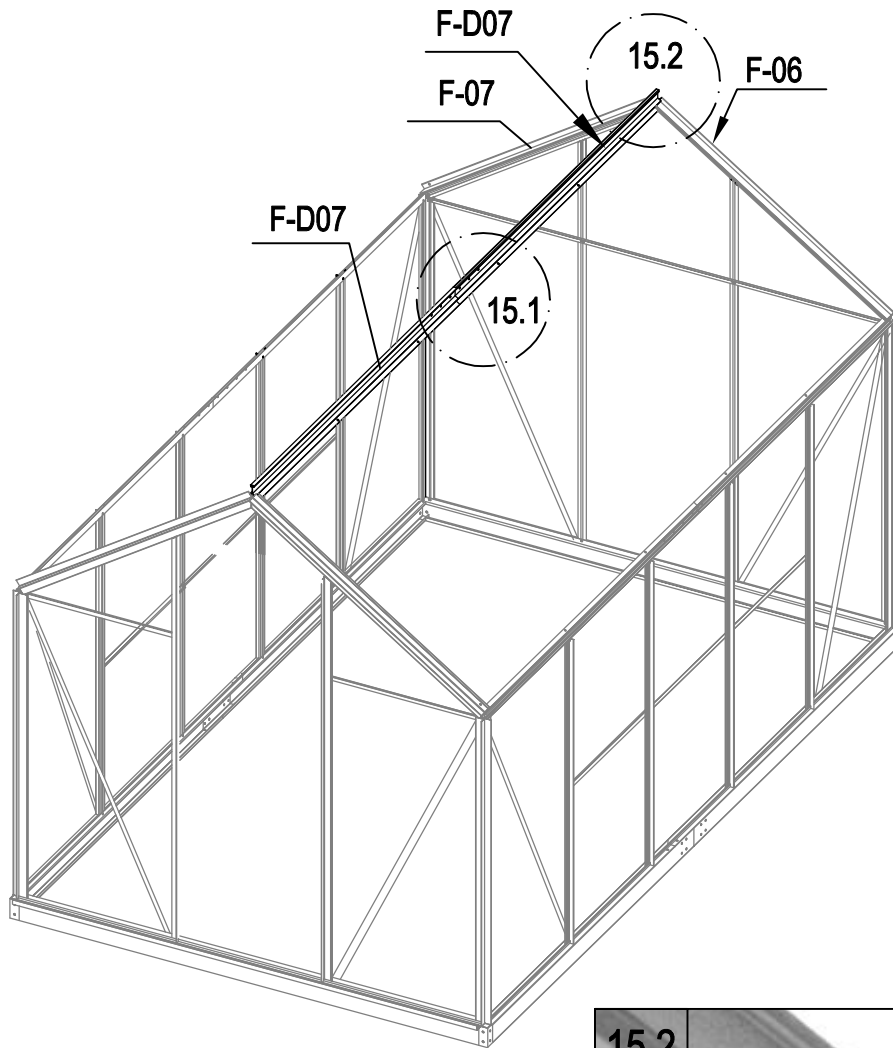

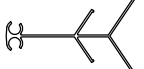
	F-06	2
	F-07	2
	F-19	4
	F-D14	8



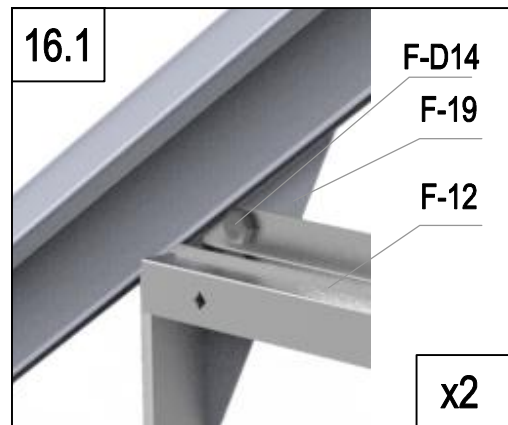
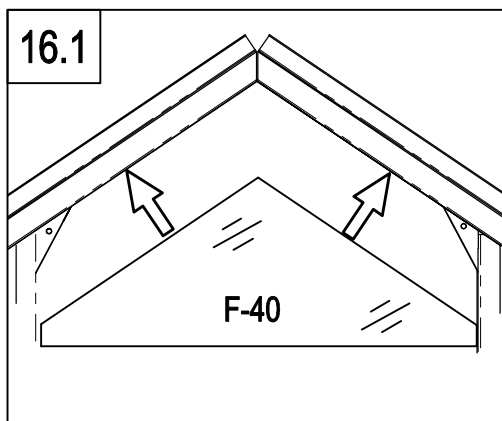
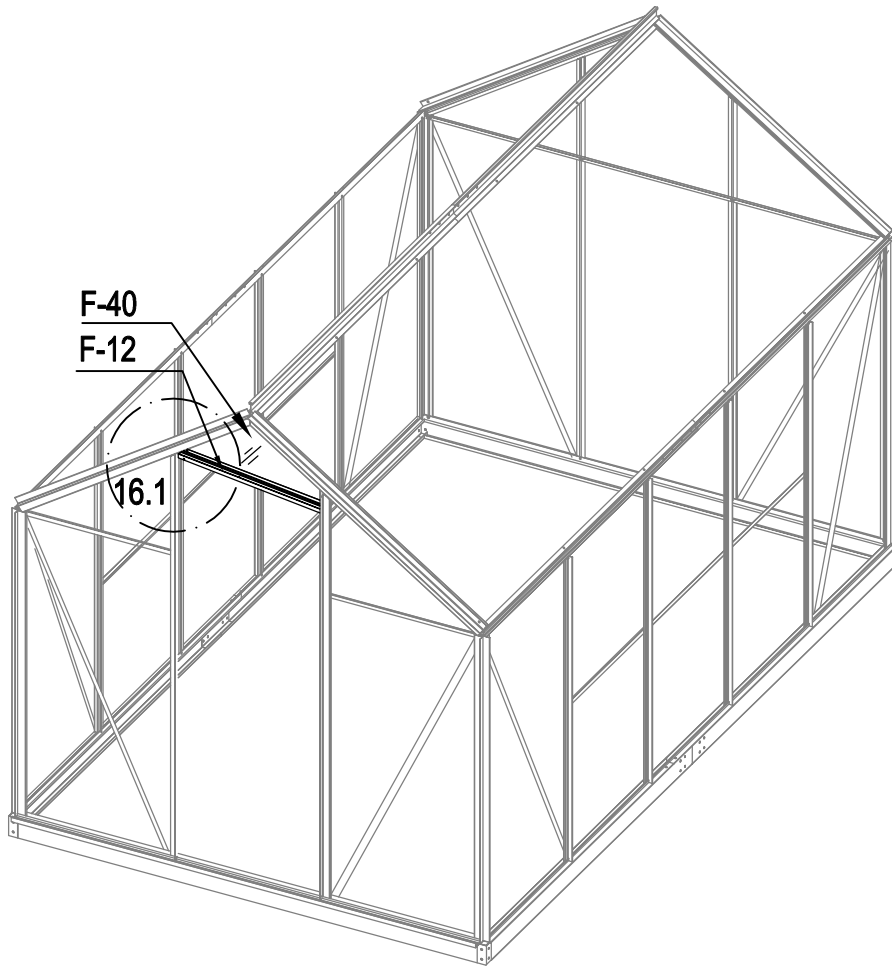

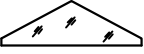
	F-D07	2
	F-43	2
	F-D14	10

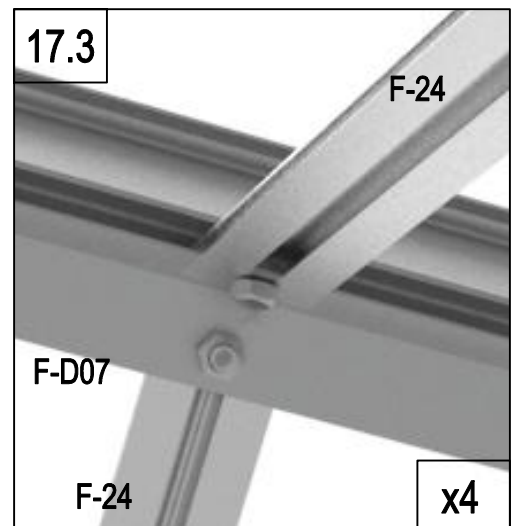
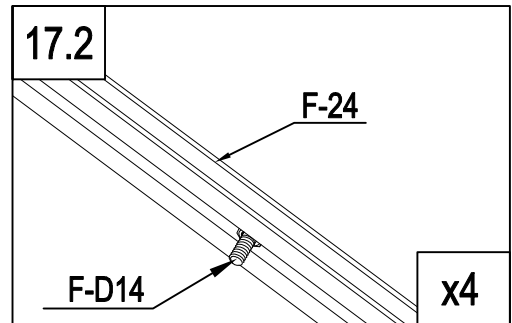
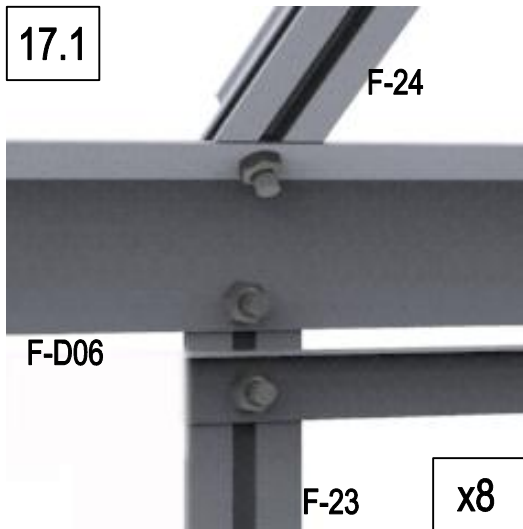
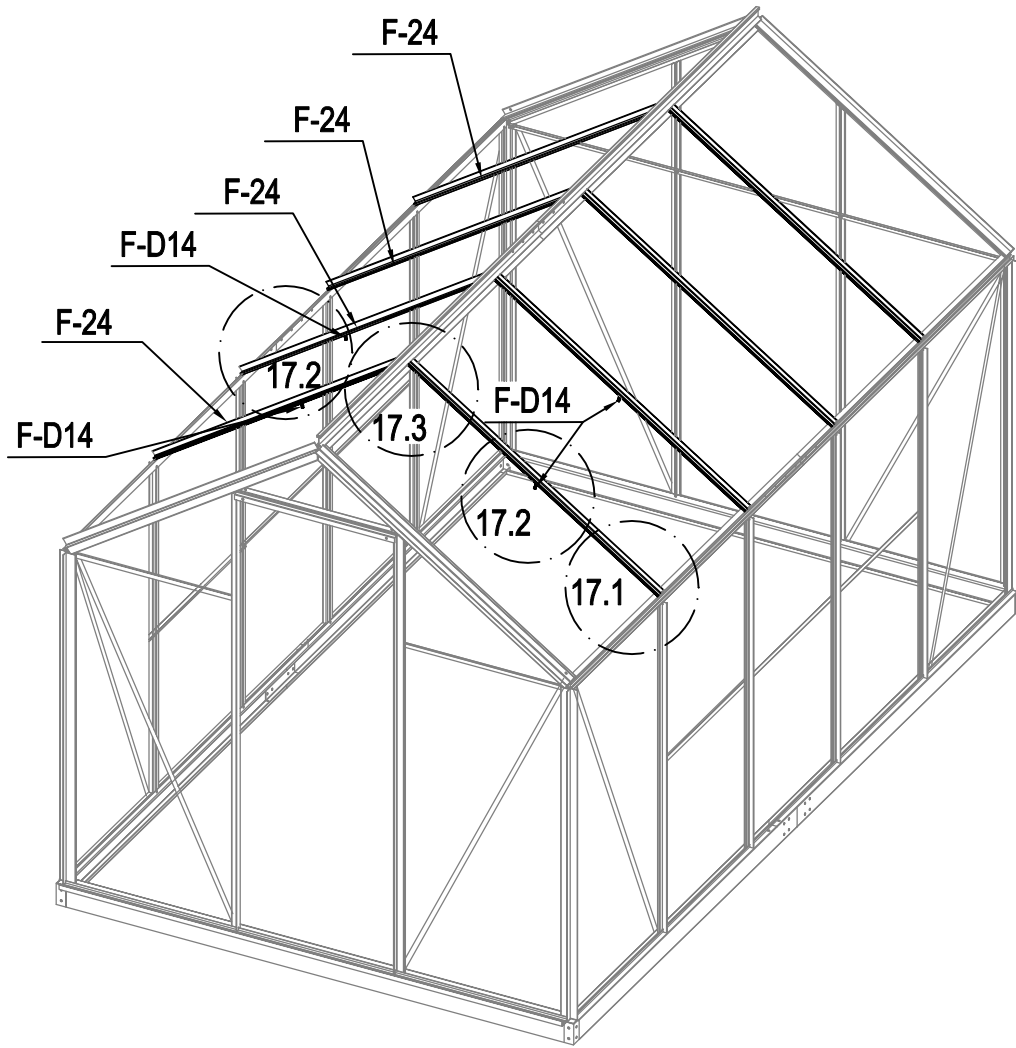

	F-12	1
	F-40	1
	F-D14	2



	F-24	8
	F-D14	20

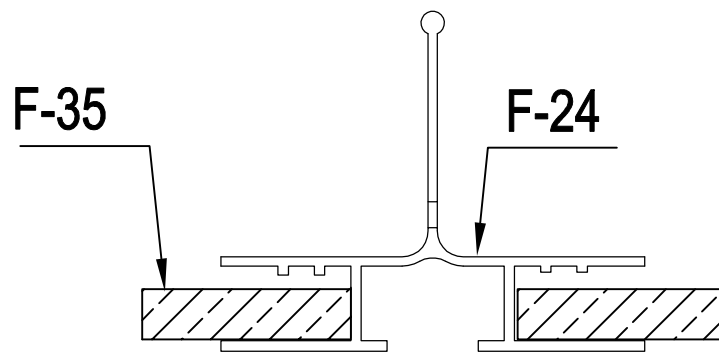
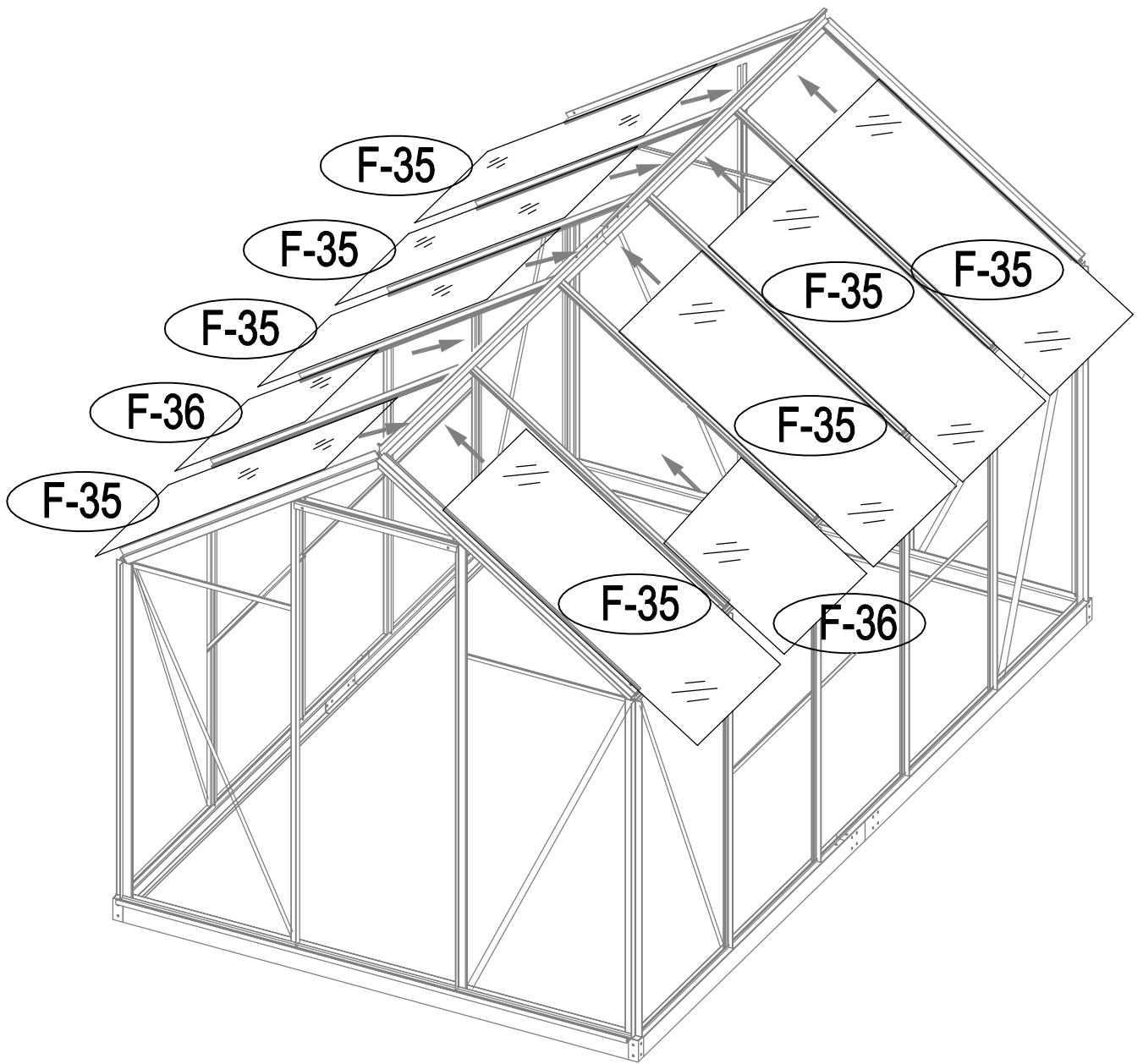

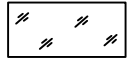
	F-36	2
	F-35	8

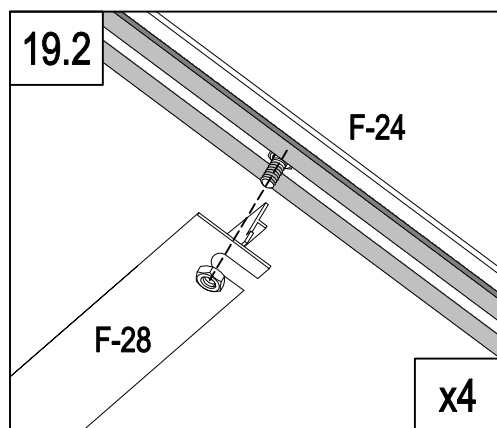
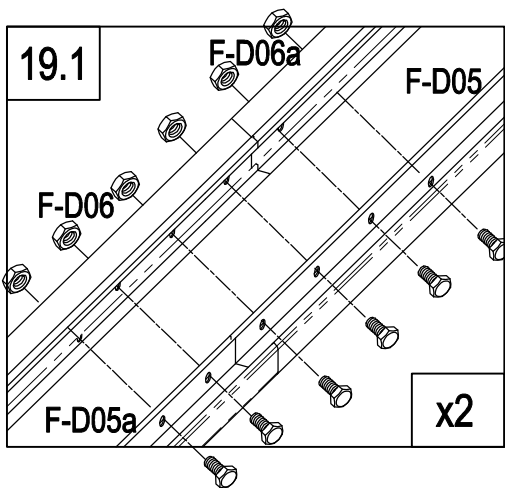
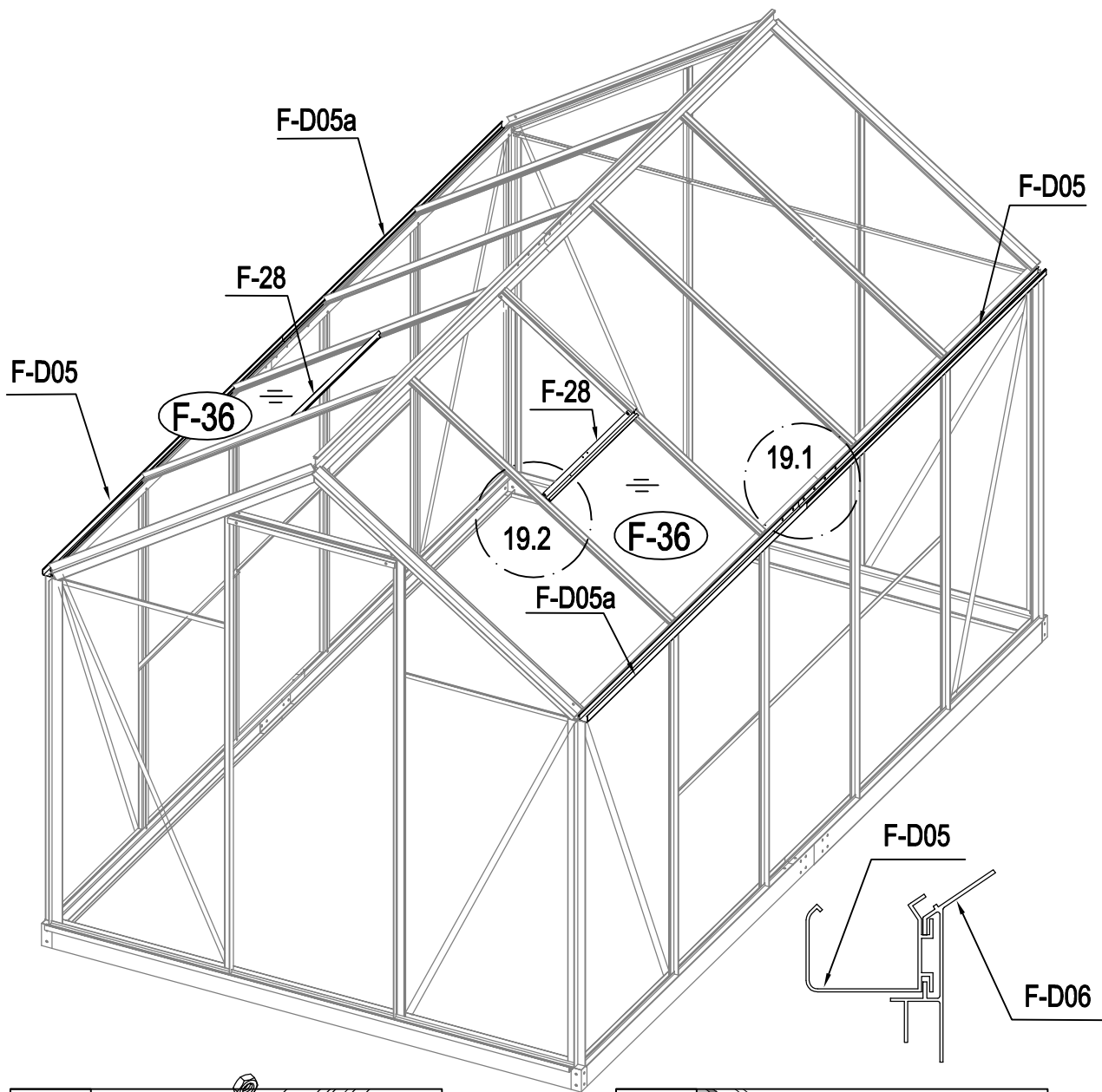

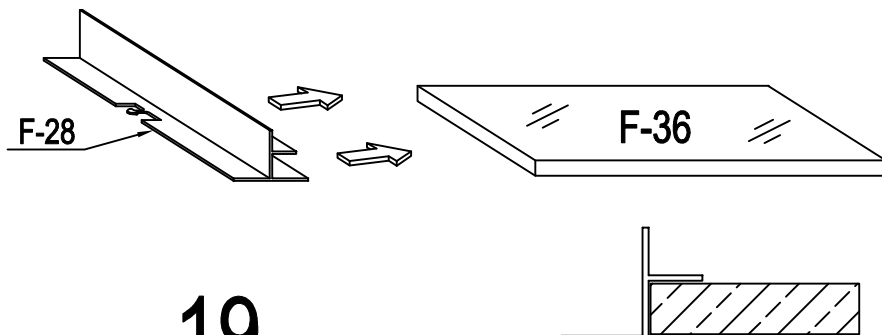

	F-28	2
	F-D05	2
	F-D05a	2
	F-D14	12



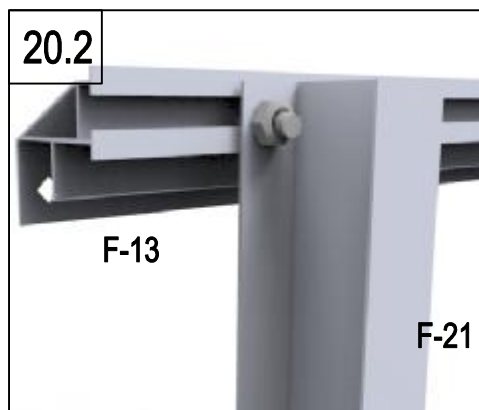
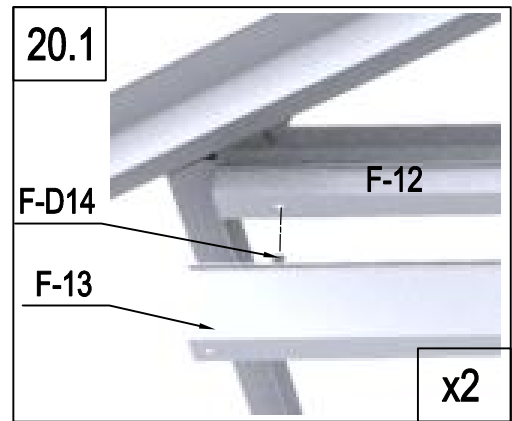
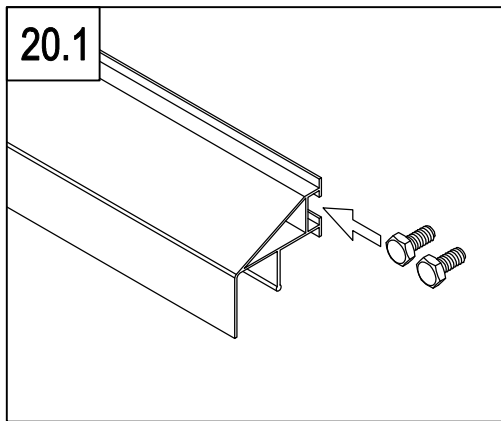
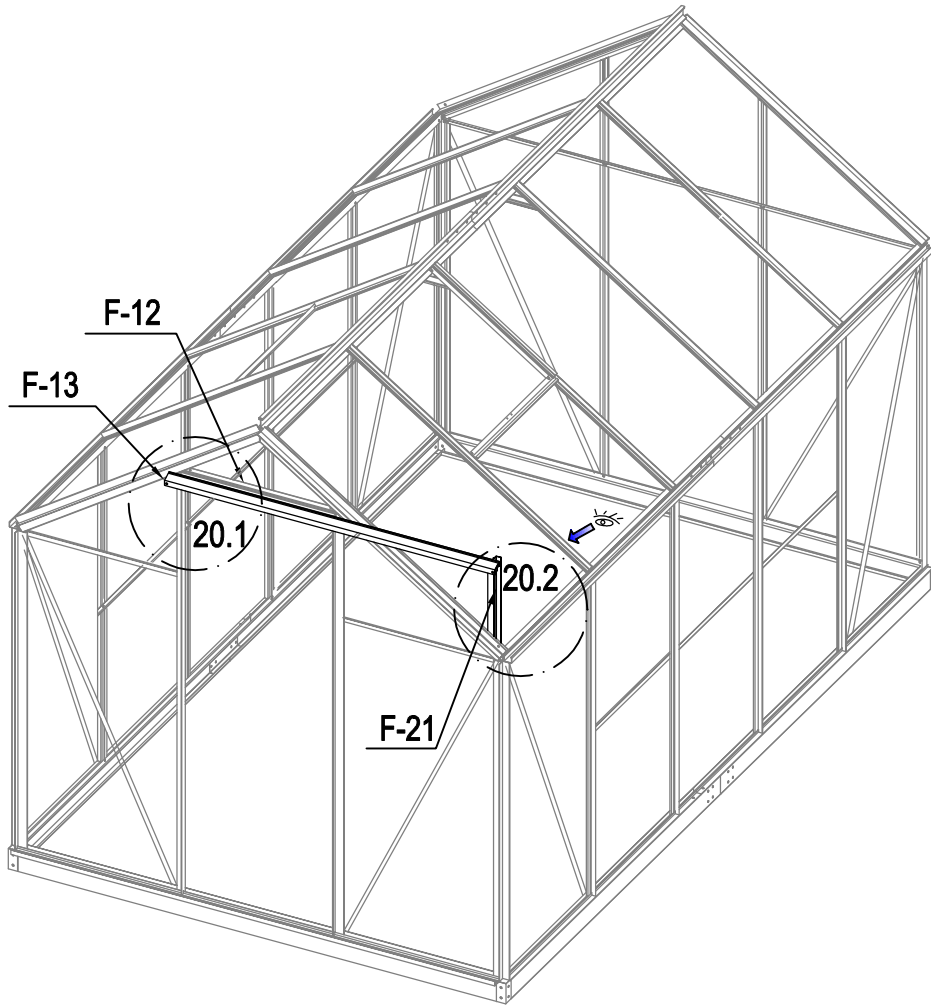





19

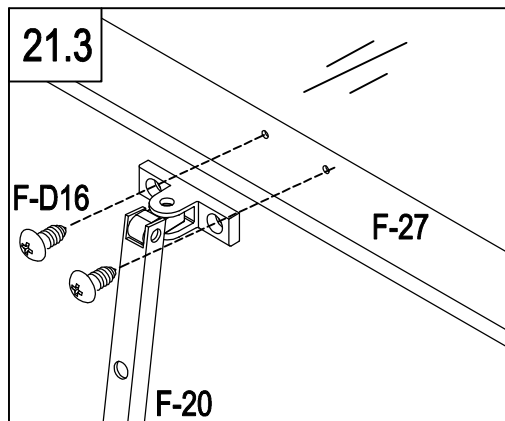
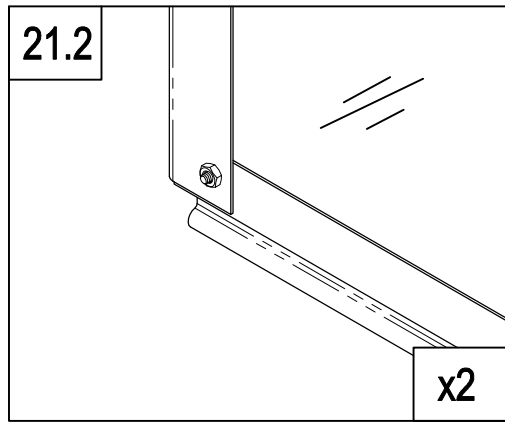
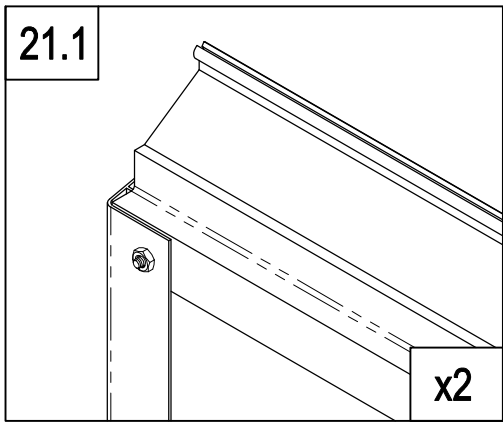
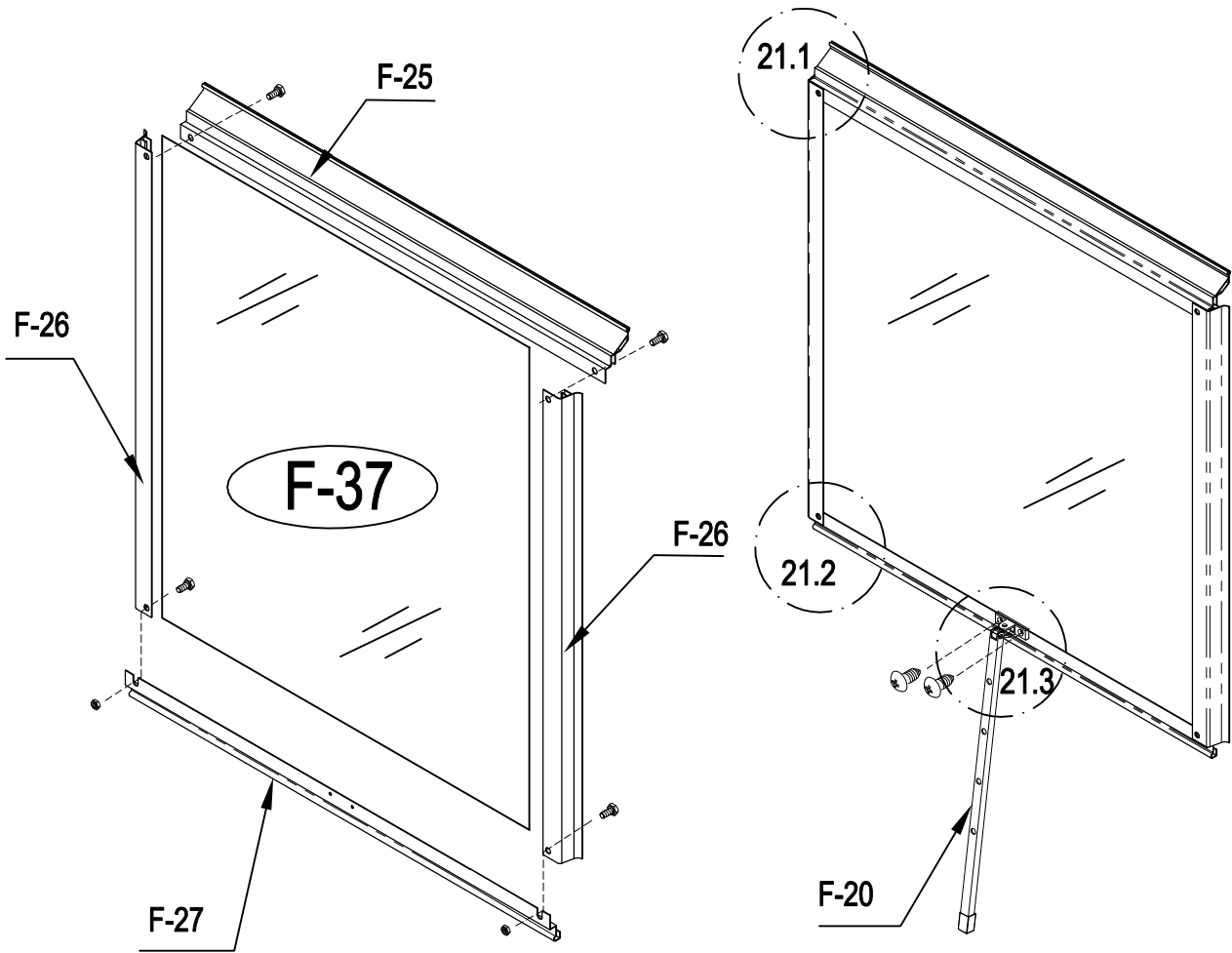

	F-13	1
	F-21	1
	F-D14	4

20

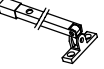
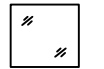

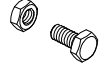
	F-25	2
	F-26	4
	F-27	2
	F-20	2
	F-37	2
	F-D16	4
	F-D14	8

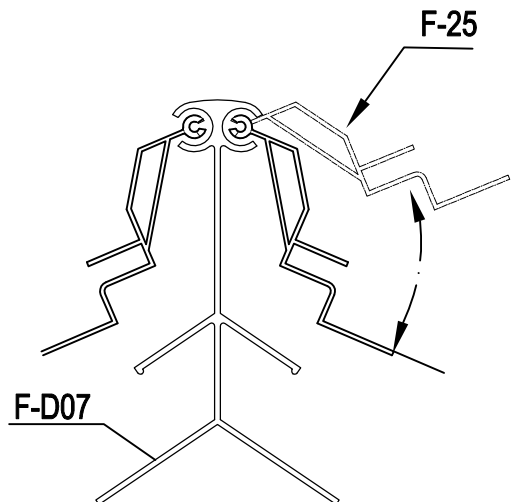
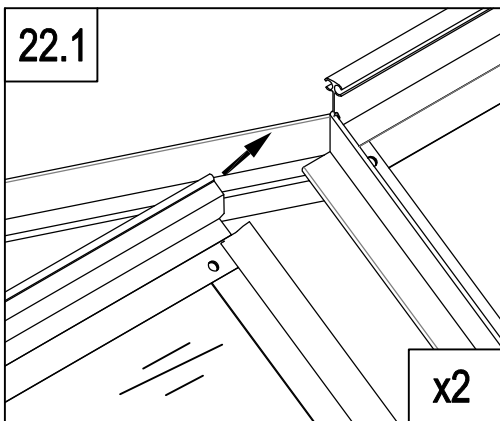
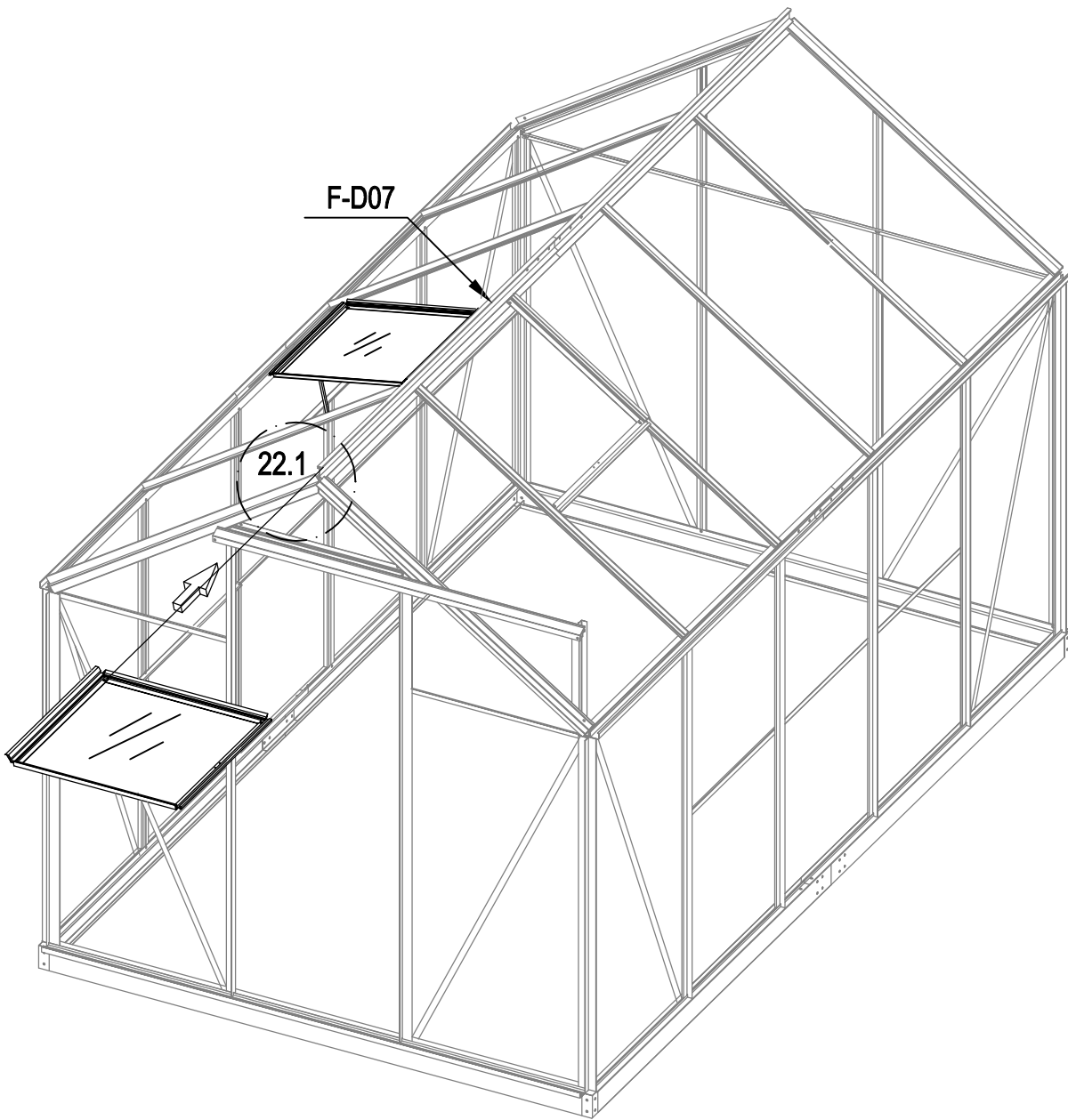

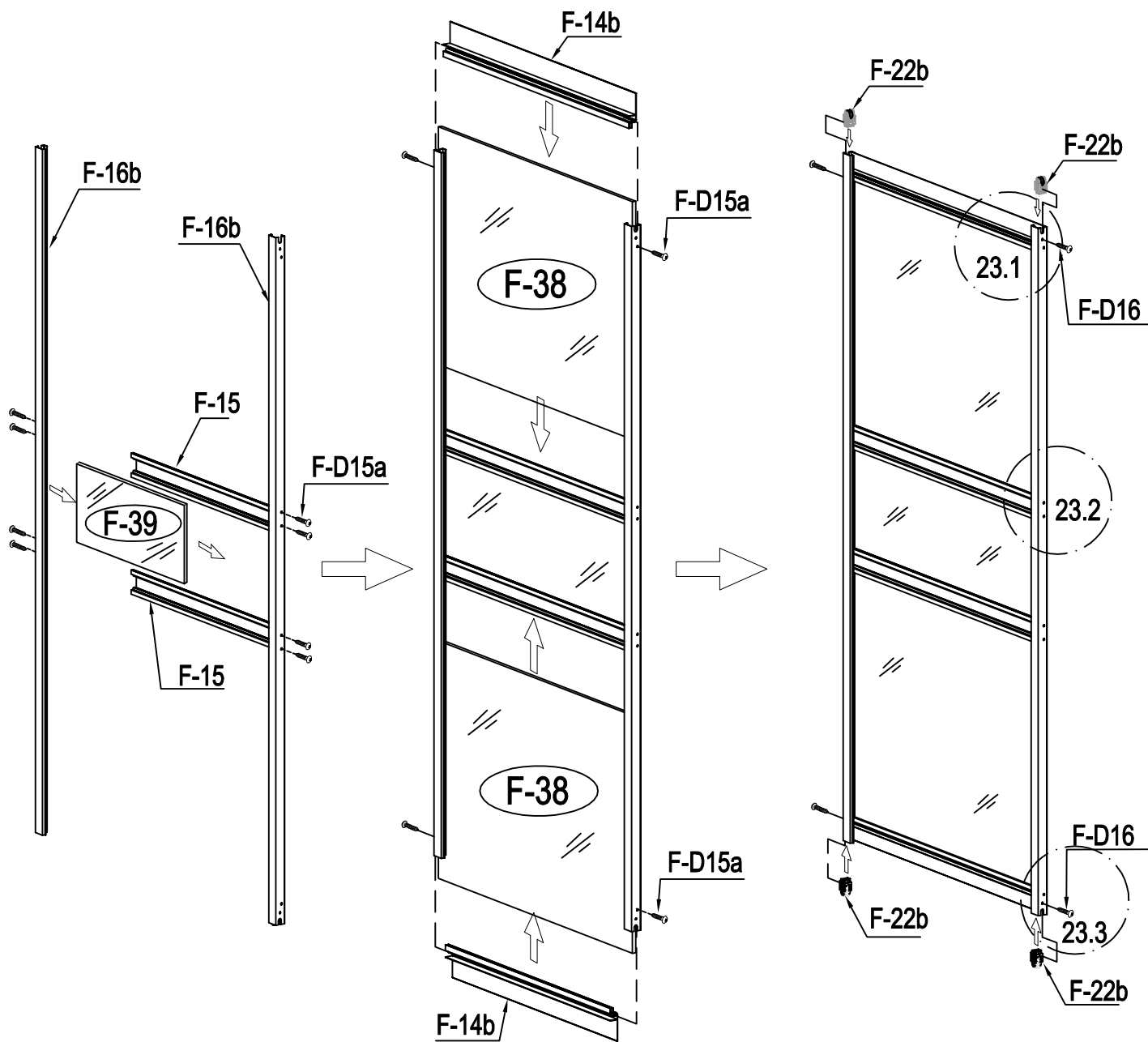

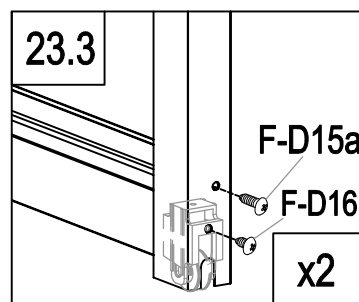
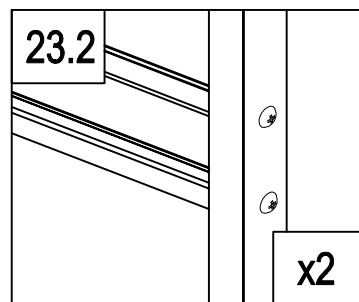
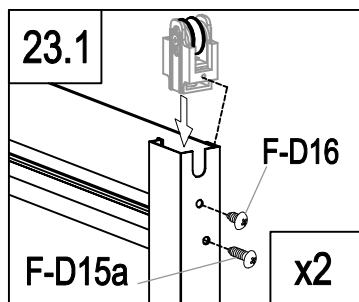

	F-38	2
	F-39	1
	F-16b	2
	F-14b	2
	F-15	2
	F-22b	4
	F-D15a	12
	F-D16	4

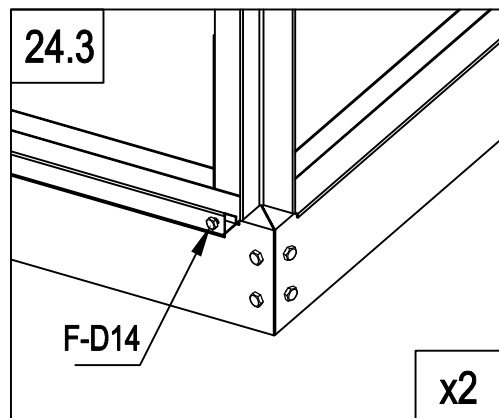
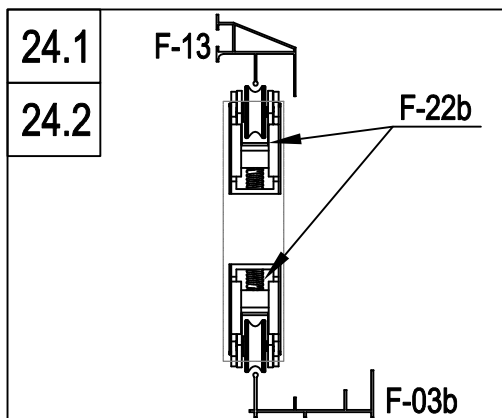
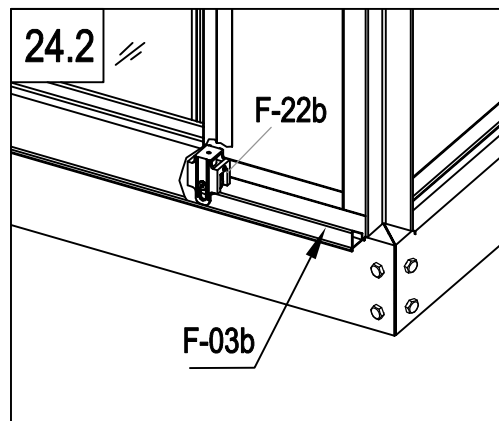
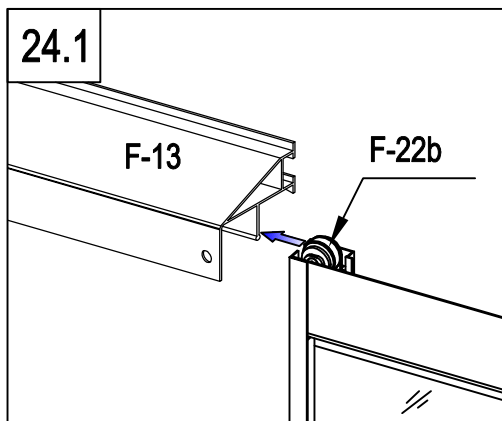
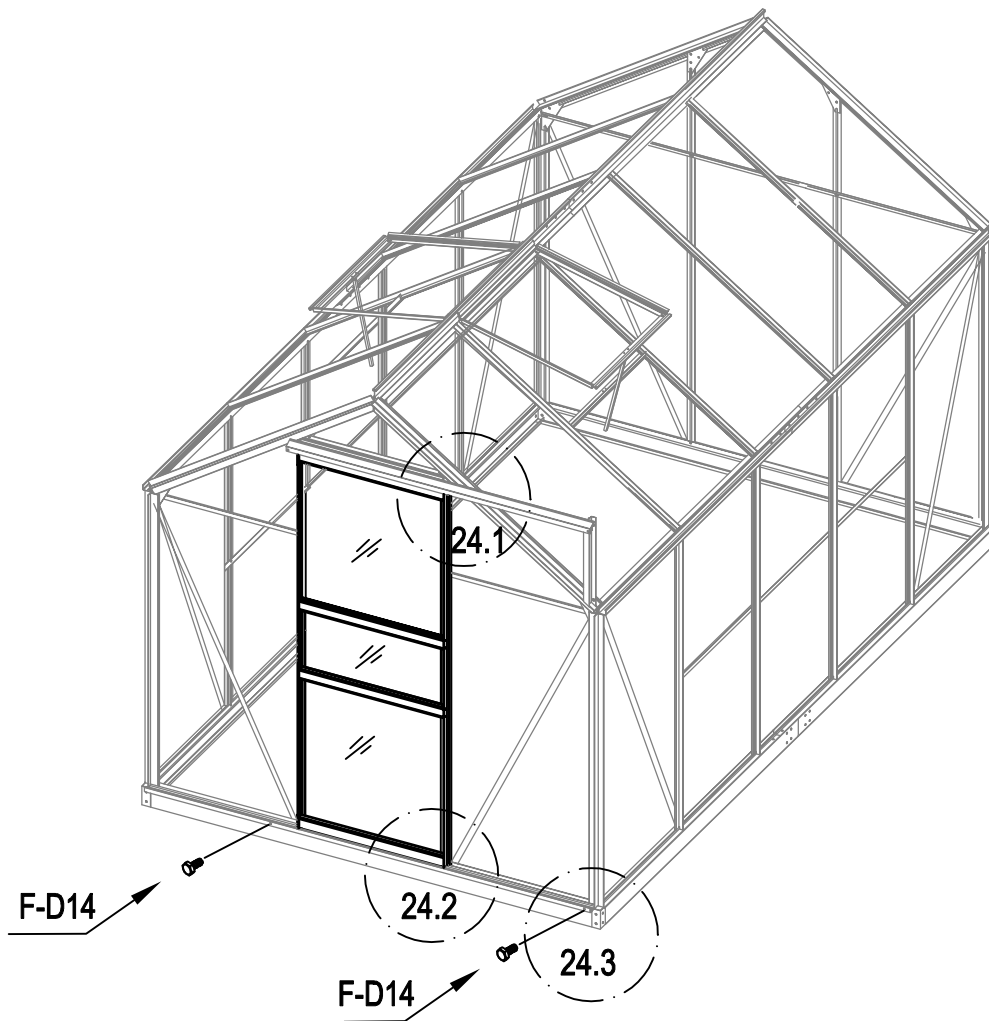

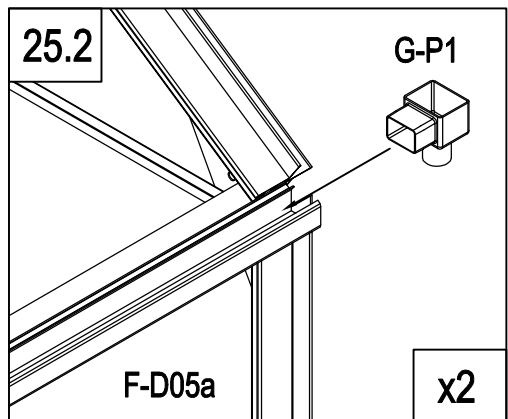
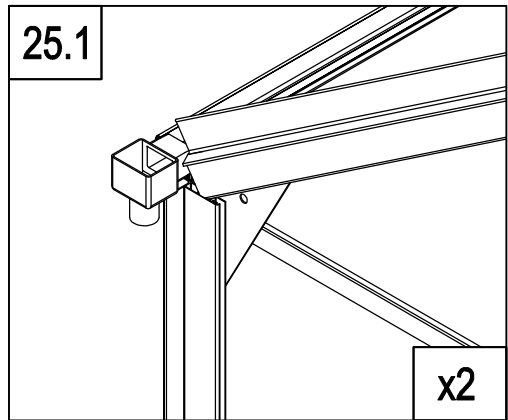
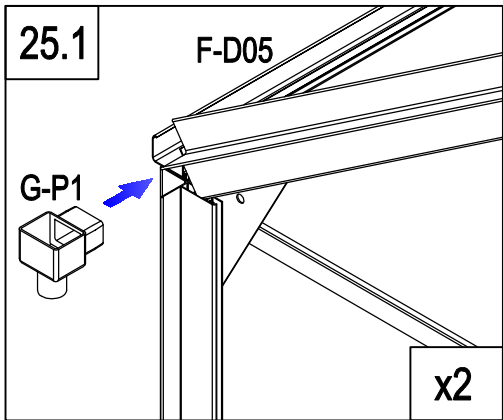
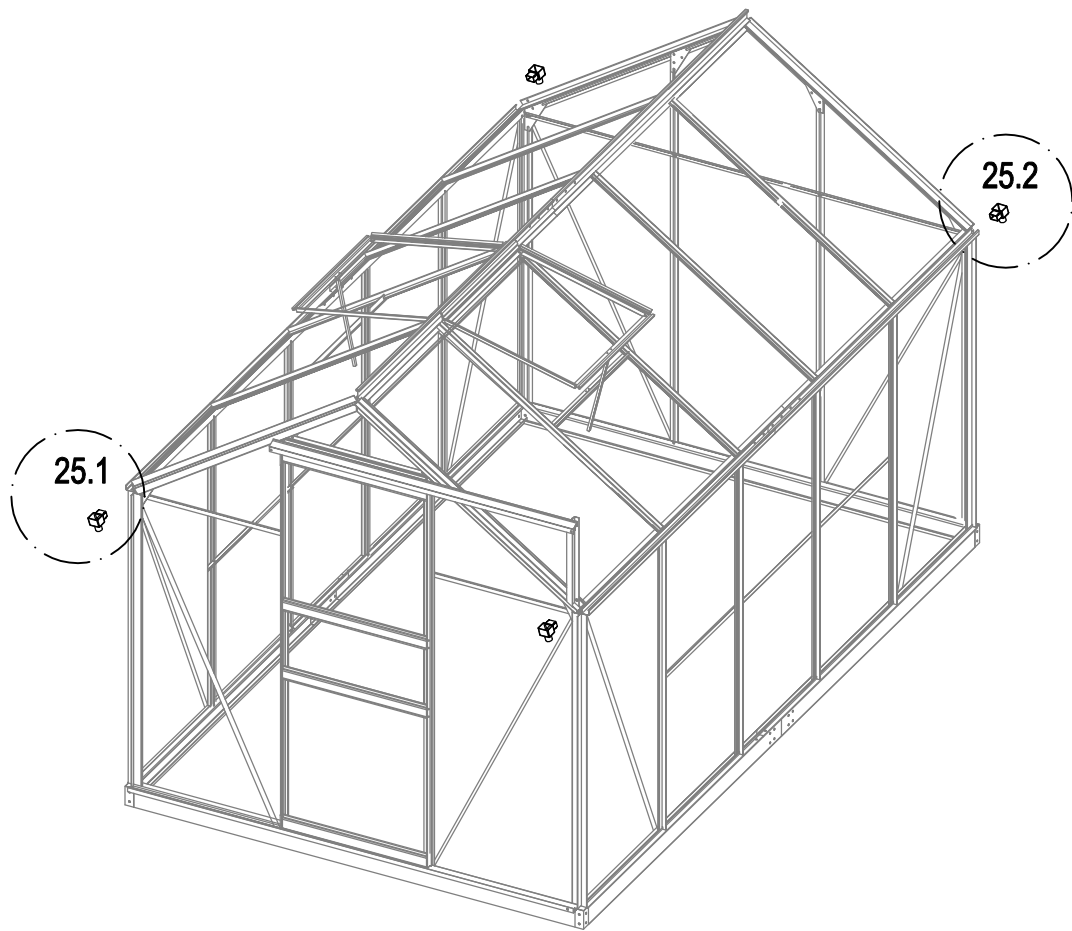

	F-D14	2
--	-------	---



	G-P1	4
---	------	---

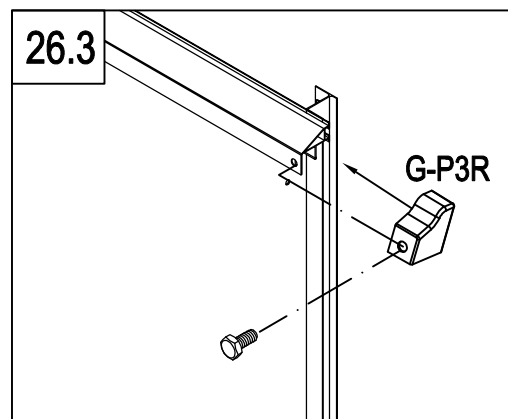
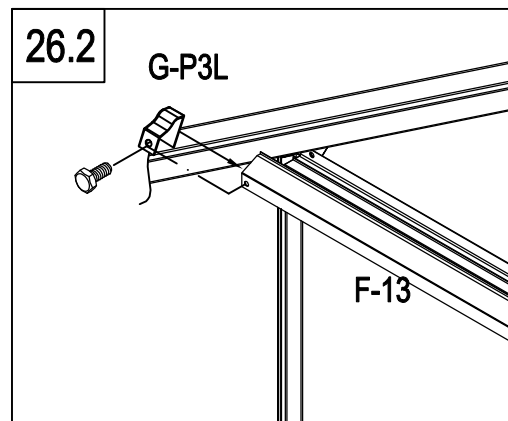
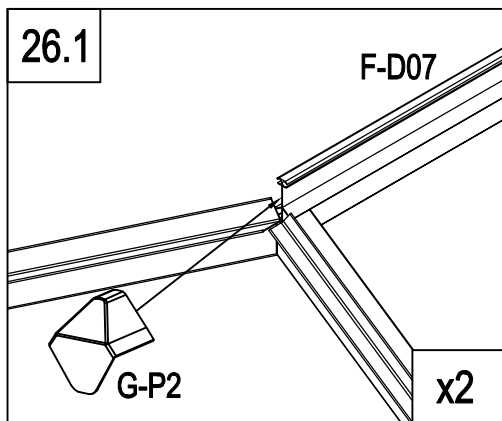
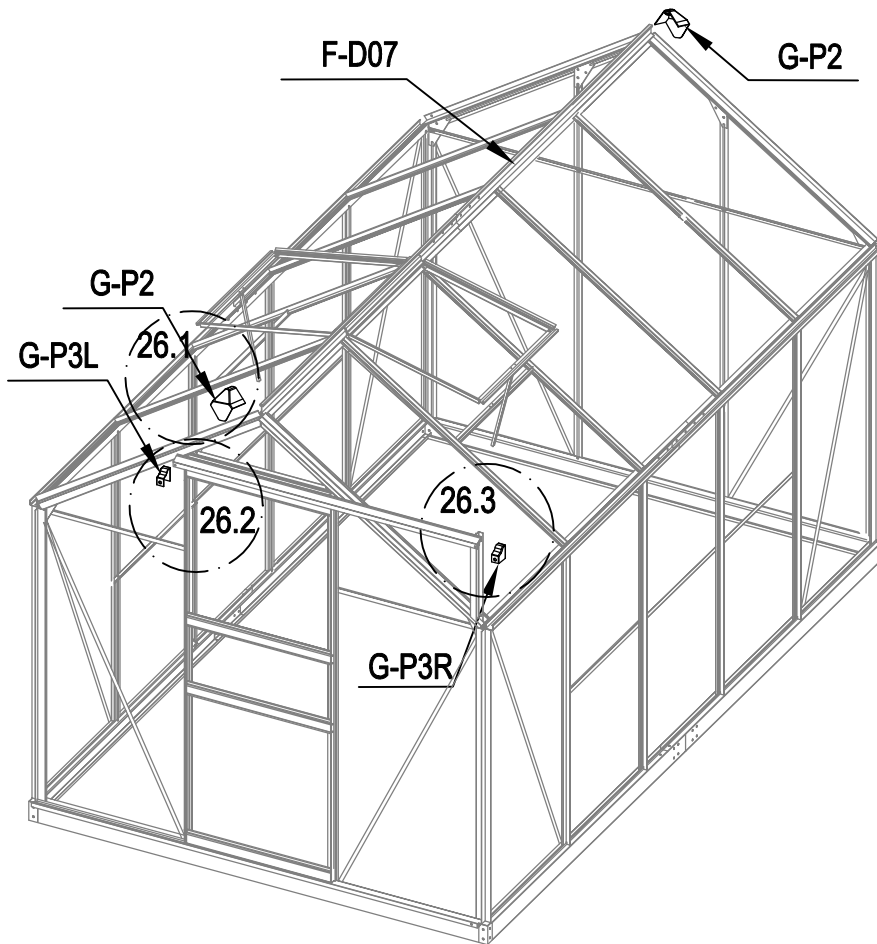

	G-P2	2
	G-P3L	1
	G-P3R	1
	F-D14	2

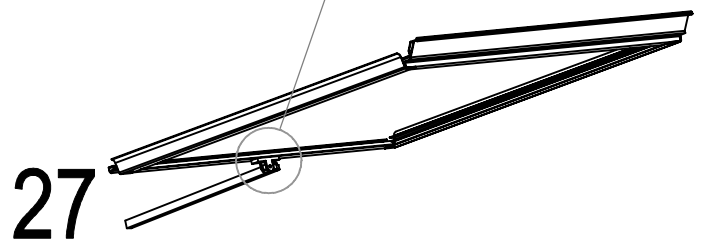
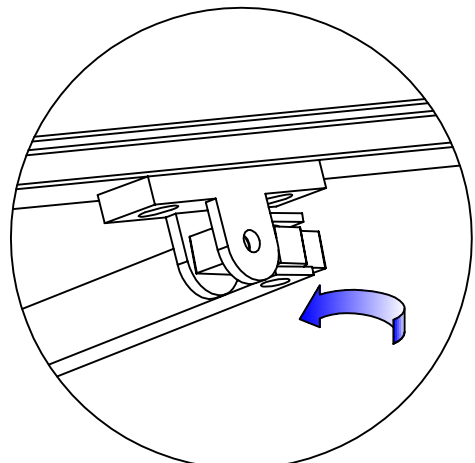
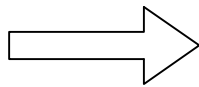
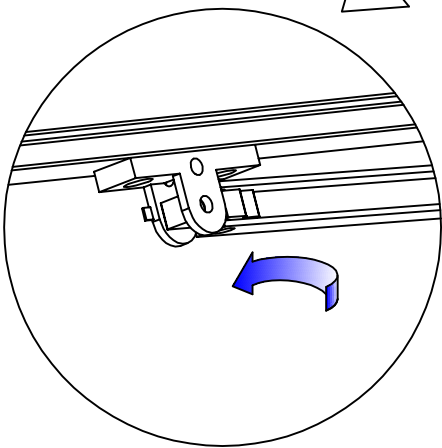
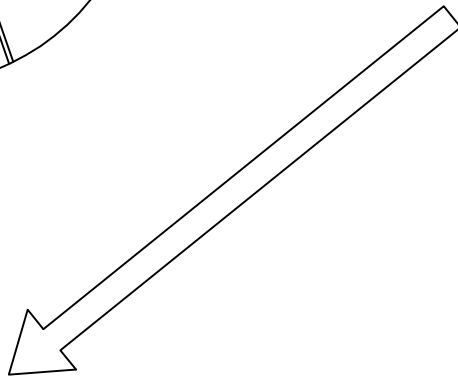
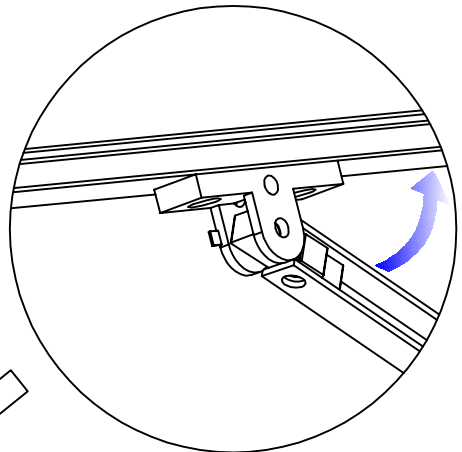
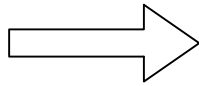
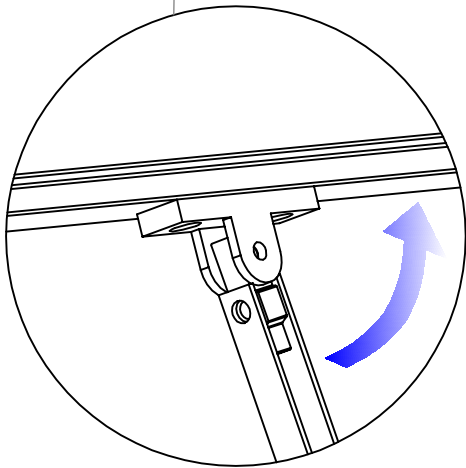
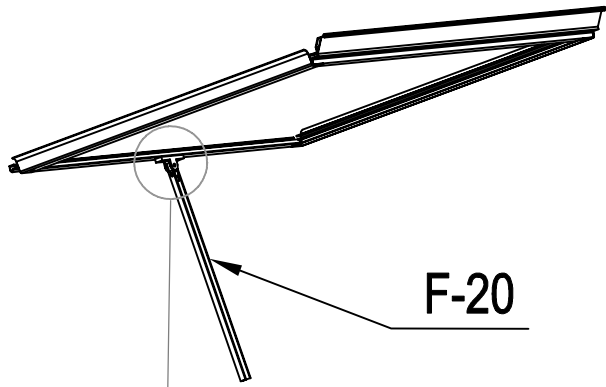

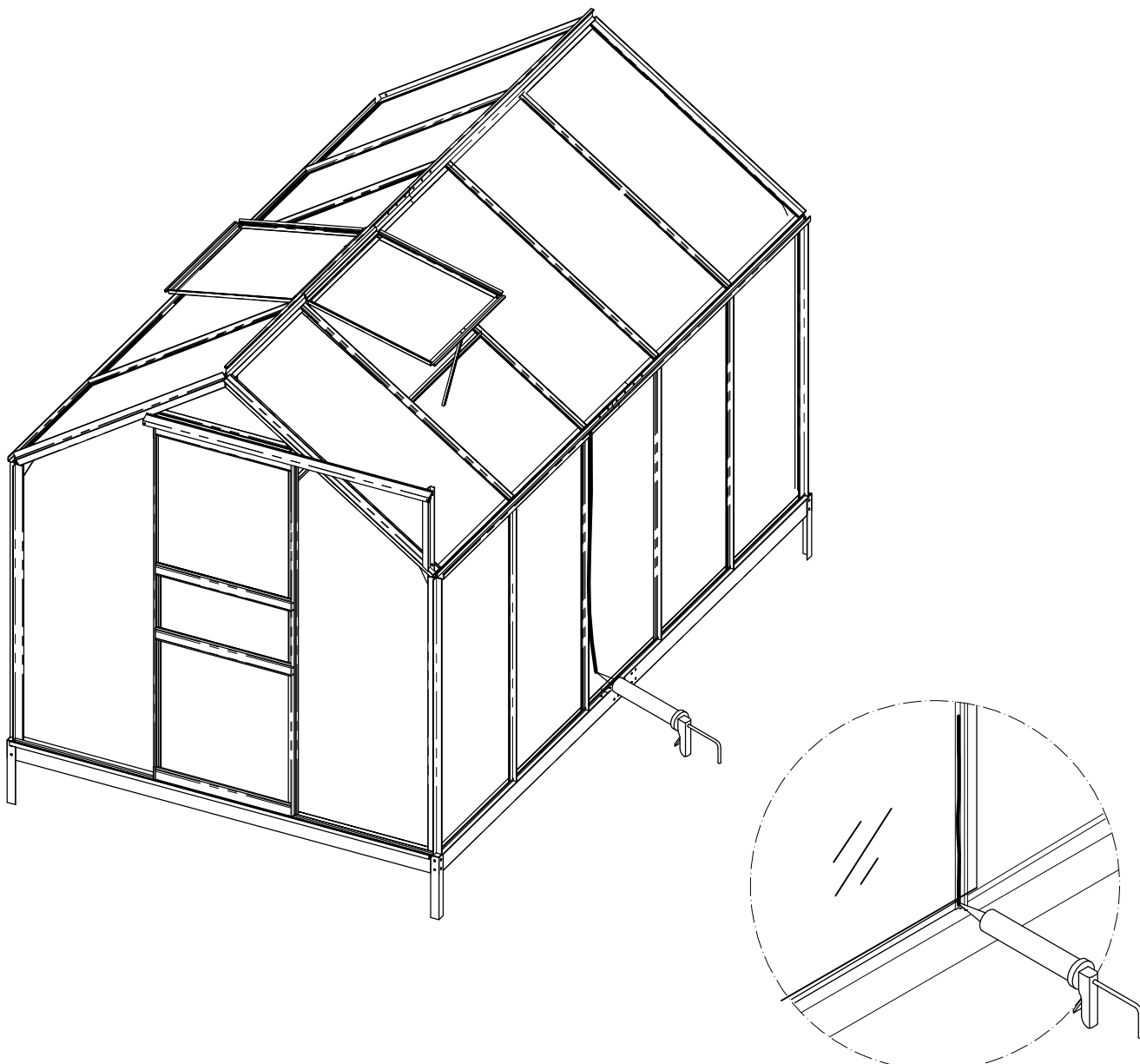

Poradenství

- pro větší pevnost můžete také použít lepidlo nebo pásky mezi stabilito
- silikonový tmel a lepicí pistole nejsou součástí naší sady nářad
- silikonový tmel používejte pouze na hliníkové část